

BUSH RADIO

Service Instructions

A.C. Mains
MODEL A.C.81

D.C. A.C. Mains
MODEL D.A.C.81



Front View A.C.81 and D.A.C.81

REFERENCE TABLE.

| Section | Page | Section | Page |
|--|-------|--|------|
| A.C.81 to D.A.C.81, Conversion of | 3 | Scale Lamps, Replacement of | 8 |
| Circuit Alignment | 7 | Mains Chokes. (D.A.C.81 only) | 8 |
| Circuit Description | 9 | Mains Supply Unit. (D.A.C.81 only) | 8 |
| Coil Data | 4 | Mains Transformer. (A.C.81 only) | 4 |
| Coil Deck Connections | 4 | Operating on 110-115 Volts Supply. (D.A.C.81 only) | 7 |
| Dismantling | 7 | Output Transformer | 8 |
| Drive Cord, Fitting | 8 | Resistors | 3 |
| Faults Table | 9, 10 | Speaker | 8 |
| Fixed Condensers | 3 | Specification | 1 |
| I.F. Transformer, Modifications | 2 | Valve Data | 6 |
| Gramophone Pick-up and Motor, Connecting (D.A.C.81 only) | 7 | Variable Condensers | 3 |
| | | Warning. (D.A.C.81 only) | 3 |

SPECIFICATION.

BASIC DESIGN—

A five-valve (including rectifier), three waveband superheterodyne, with six tuned circuits.

VALVES—

Mullard—

CCH.35 (Heater 7 v.)
EF.39 (Heater 6.3 v.)
EBC.33 (Heater 6.3 v.)
CL.33 (Heater 33 v.)
CY.31 (Heater 20 v.)

All valves Octal bases. Heater current 0.2 amp.

SCALE LAMPS—

Three provided to illuminate Tuning Scale.
Type 6.2 volt, 0.3 amp.

VOLTAGE ADJUSTMENTS—

A.C.81 Model—

200—250 volts, 40—100 cycles.

D.A.C.81 Model—

Supply mains of voltages

180—210 place Red plug into Socket 200.
211—230 place Red plug into Socket 220.
231—250 place Red plug into Socket 240.

For operating on 100—115 volt supply, see special note on Page 7.

MAINS CONSUMPTION—

A.C.81 Model—

Approximately 40 watts.

D.A.C.81 Model—

Approximately 70 watts.

AUDIO OUTPUT—

1.5 watts to the speaker.

WAVELENGTH RANGE—

S.W. ... 16.5—51 metres (18.18—5.88 Mc/s).
M.W. ... 198—560 metres (1,515.3—535.7 Kc/s.).
L.W. ... 850—2,000 metres (352.9—150 Kc/s.).

INTERMEDIATE FREQUENCY—

465 Kc/s.

CONTROLS—

Facing front of set, from left to right—

- ON/OFF Switch and Tone Control.
- Volume Control.

3. Tuning Control.

4. Three-position wave-range switch.

Turning in a clockwise direction the position are LONG, MEDIUM and SHORT wavebands.

AERIAL AND EARTH—

Two alternative aerial sockets are provided—

Top left hand socket: maximum sensitivity. (facing back of cabinet)

Centre socket : : : maximum sensitivity.

Bottom socket : : : earth.

D.A.C.81 Model—Care should be taken not to touch the chassis and the earth connection when fitting the earth plug into the socket, or to let the earth plug touch the chassis.

GRAMOPHONE PICK-UP—

Sockets are provided on the extreme right of the chassis (facing back of cabinet).

A pick-up of approximately 700 ohms D.C. resistance recommended.

When using a pick-up, the set should be tuned off a powerful station to prevent radio "break-through."

EXTERNAL SPEAKER—

Two sockets provided (towards the centre of the chassis). Plug to disconnect internal speaker.

This plug should always be inserted in the top socket unless an Extension is connected.

For an external speaker, the "BUSH EXTENSION SPEAKER" is recommended, as it is fitted with an independent volume control and ON/OFF Switch. Alternatively, a permanent magnet type with a speech coil of 2.5 ohms impedance may be used (no transformer required).

MAINS CONNECTION—

On the **D.A.C.81** model, a detachable mains lead is provided which should be plugged into the 2-pin plug fitted on the extreme left-hand end of the chassis (facing the back of the cabinet).

CABINET DIMENSIONS—

A.C.81; D.A.C.81.
19½ ins. long; 13½ ins. high; 11½ ins. back to front.

CIRCUIT DIAGRAM A.C.81 and D.A.C.81

www.radio-workshop.co.uk

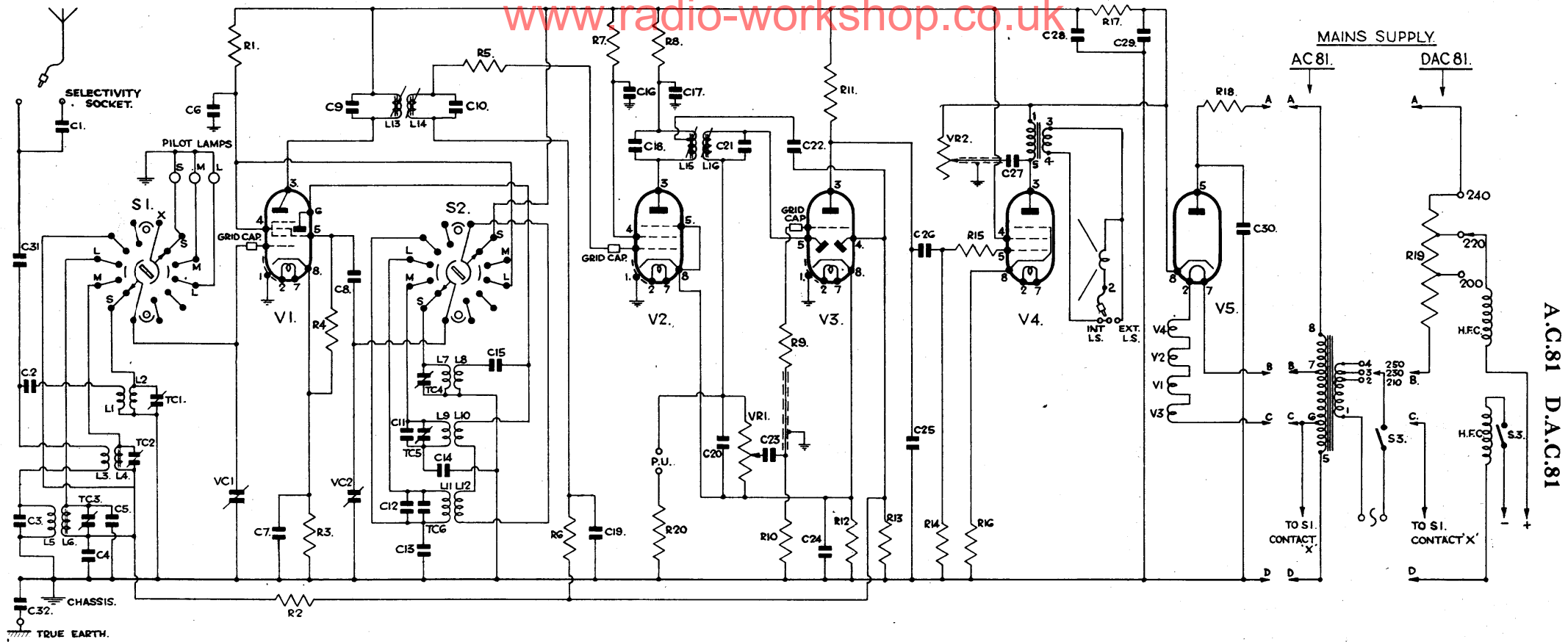

SWITCH SECTIONS.

Switch sections S1 and S2 are shown in the circuit diagram as viewed from the rear of the chassis, the right-hand side of each being nearest to the coil mounting platform.

I.F. TRANSFORMERS MODIFICATION.

On early serial numbers of the A.C. 81 and D.A.C.81 chassis, the first and second I.F. Transformers will have the primary and secondary with fixed iron cores, each winding being tuned by 20-90 mmfd. trimmers. The primary of the second I.F. Transformer is not tapped and C22 connects direct to the hot end of the secondary and C21. The early I.F. Transformers are replaceable by the variable iron core type.

- Part No. for FIXED IRON CORE TYPE—**
 First I.F. Transformer : S.10057F.
 Second I.F. Transformer : S.9508.

VALVES.

1. Mullard CCH.35 Octal Base (Met) Frequency changer.
2. Mullard EF.39 Octal Base (Met) Intermediate Frequency Amplifier.
3. Mullard EBC.33 Octal Base (Met) Second Detector, AVC and AF Amplifier.
4. Mullard CL.33 Octal Base Output Pentode.
5. Mullard CY.31 Octal Base Half-wave H.T. Rectifier.

OCTAL VALVE BASE PIN NUMBERS.

The view shown is of the valve base itself or the underside of the valve holder.

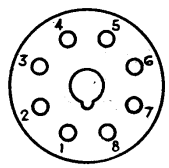

A.C.81 D.A.C.81

RESISTORS.

| | Value ohms | Rate Watts | Description |
|-------|-------------|------------|--|
| R.1 | 22,000 | 1 | V.1 S/g's and Osc./Anode decoupling. |
| R.2 | 1 Meg. | ¼ | V.1 hexode C/g. decoupling. A.V.C. line. |
| R.3 | 100 | ¼ | V.1 cathode bias. |
| R.4 | 33,000 | ¼ | V.1 Osc. C/g. resistor. (Insulated type.) |
| R.5 | 47 | ¼ | V.2 C/g. stabiliser. (Insulated type.) |
| R.6 | 1 Meg. | ¼ | V.2 C/g. decoupling. A.V.C. line. |
| R.7 | 47,000 | ½ | V.2 Screen decoupling. |
| R.8 | 10,000 | ½ | V.2 Anode decoupling. |
| R.9 | 100,000 | ½ | V.3 Triode C/g. stopper. (Insulated type.) |
| R.10 | 2.2 Meg. | ¼ | V.3 Triode grid return. |
| R.11 | 68,000 | ¼ | V.3 Triode anode load. |
| R.12 | 220 | ¼ | V.2 and V.3 common cathode bias. |
| R.13 | 1 Meg. | ¼ | V.3 A.V.C. diode load. |
| R.14 | 470,000 | ¼ | V.4 Control grid return. |
| R.15 | 47,000 | ¼ | V.4 C/g. stopper. |
| R.16 | 150 | ¼ | V.4 Cathode bias. |
| R.17 | 10,000 | 2 | H.T. line smoothing. |
| R.18 | 100 | 1 | V.5 Anode surge resistor. |
| R.19 | 600+100+100 | 30 | Heater circuit ballast. (Vitreous type.) USED ON MODEL D.A.C.81 ONLY. |
| R.20 | 47,000 | ¼ | P.U. isolating resistor, and signal diode bias. USED ON MODEL D.A.C.81 ONLY. |
| V.R.1 | 500,000 | — | Manual volume control. Part No. P3740. |
| V.R.2 | 25,000 | — | Variable tone control with S.3 ganged. Part No. P3290. |

A tolerance of $\pm 20\%$ is permissible on all fixed resistors with the exception of R.16 which is $\pm 10\%$.

D.A.C.81—An additional resistor is fitted in the hot side of the pick-up sockets—47,000 ohms $\frac{1}{4}$ watt $\pm 20\%$.

WARNING—D.A.C.81 RECEIVER.

When servicing the D.A.C.81 Receiver, remember the chassis is connected to one side of the mains, and therefore, under certain circumstances, will be "live".

Do not connect an "Earth" direct to the chassis or touch the chassis when working under these conditions.

CONDENSERS.

www.radio-workshop.co.uk

| | Value mmfd. | Tol. $\pm\%$ | Type | Working Voltage D.C. | Description |
|-------|-------------|--------------|--------------|----------------------|--------------------------------------|
| C.1 | 50 | 20 | Mica | 350 | Aerial series capacity. |
| C.2 | 50 | 20 | Mica | 350 | Aerial S.W. coupling. |
| C.3 | 800 | 20 | Mica | 350 | L.W. Aerial shunt. |
| C.4 | 0.1 mfd. | 20 | Tubular | 350 | V.1 A.V.C. line decoupling. |
| C.5 | 30 | 10 | Silver mica | 350 | L.W. Preselector capacity. |
| C.6 | .05 mfd. | 20 | Tubular | 350 | V.1 S/g's and Osc. anode decoupling. |
| C.7 | .05 mfd. | 20 | Tubular | 350 | V.1 Cathode by-pass. |
| C.8 | 30 | 20 | Mica | 350 | V.1 Osc. control grid capacity. |
| C.9 | 110 | 2 | Silver mica | 350 | 1st I.F.T. primary capacity. |
| C.10 | 110 | 2 | Silver mica | 350 | 1st I.F.T. secondary capacity. |
| C.11 | 20 | 10 | Silver mica | 350 | M.W. Osc. tuning capacity. |
| C.12 | 130 | 5 | Silver mica | 350 | L.W. Osc. tuning capacity. |
| C.13 | 316 | 1 | Silver mica | 350 | L.W. Osc. padding. |
| C.14 | 556 | 1 | Silver mica | 350 | M.W. Osc. padding. |
| C.15 | 50 | 10 | Silver mica | 350 | S.W. Osc. anode coupling. |
| C.16 | .05 mfd. | 20 | Tubular | 350 | V.2 S/g. decoupling. |
| C.17 | .05 mfd. | 20 | Tubular | 350 | V.2 anode decoupling. |
| C.18 | 110 | 2 | Silver Mica | 350 | 2nd I.F.T. primary capacity. |
| C.19 | .05 mfd. | 20 | Tubular | 350 | V.2 A.V.C. line decoupling. |
| C.20 | 100 | 20 | Mica | 350 | I.F. by-pass. |
| C.21 | 110 | 2 | Silver Mica | 350 | 2nd I.F.T. secondary capacity. |
| C.22 | 50 | 20 | Mica | 350 | Coupling to A.V.C. diode. |
| C.23 | .01 mfd. | 20 | Tubular | 350 | A.F. Coupling to V.3. |
| C.24 | .05 mfd. | 20 | Tubular | 350 | V.2, V.3 cathodes common by-pass. |
| C.25 | .001 mfd. | 20 | Tubular | 350 | Fixed tone corrector. |
| C.26 | .01 mfd. | 20 | Tubular | 350 | A.F. Coupling to V.4. |
| C.27 | .05 mfd. | 20 | Tubular | 350 | V.4 Tone corrector. |
| C.28 | 16+16 mfd | +50 | Electrolytic | 350 | H.T. Smoothing. |
| C.29 | | -20 | | | |
| C.30 | 0.2 mfd. | 20 | Tubular | 500 | Mains R.F. by-pass. |
| *C.31 | .005 mfd. | 25 | Tubular | 450 | Aerial isolating capacity. |
| *C.32 | .005 mfd. | 25 | Tubular | 450 | True earth isolating capacity. |

* C.31 and C.32 used on D.A.C.81 Receiver only. All tubular condensers are non-inductive type.

VARIABLE CONDENSERS.

| | Value mmfd. | Type | Description |
|--|----------------|------------------------------|--|
| V.C.1 } V.C.2 } | Gang Condenser | P1991 | Aerial circuit tuning. Oscillator circuit tuning. |
| T.C.1 } T.C.2 } T.C.3 } T.C.4 } T.C.5 } T.C.6 } | 3-40 | "Postage Stamp" each P2937/1 | S.W. Aerial trimmer. M.W. Aerial trimmer. L.W. Aerial trimmer. S.W. Oscillator trimmer. M.W. Oscillator trimmer. L.W. Oscillator trimmer. |

Conversion of Receiver. A.C.81 to D.A.C.81

Should it be necessary to use the A.C.81 Receiver on D.C. Supply mains, it is an extremely simple matter to convert the chassis into the Universal Type D.A.C.81.

On the Circuit Diagram it will be seen that the terminating points A, B, C and D from the main part of the circuit can be connected either to the corresponding points of the Mains Transformer in the case of the A.C.81, or to the Mains Input Assembly Unit of the D.A.C.81.

The illustration on page 5 of the "Top view of the D.A.C.81 Chassis" shows the Mains Input assembly unit; this can be supplied complete for mounting on the chassis in place of the Mains Transformer.

The mains lead should be disconnected from the Transformer. Part of this lead can be used to rewire S3 (ON/OFF Switch) to one of the mains input pins and also to one side of the R.F. Chokes.

The wire from S1 contact "X" should be disconnected from Tag 6 on the Transformer and taken to the open side of the heater of V3 (pin 7, reference "C" on Diagram), thus competing the heater circuit of the valves, via the scale lamps.

The other small modifications are the insertion of C31 (.005 mmfd aerial isolating condenser) between the lead from the coil deck L3 Tag 4 to the top aerial socket.

C32 (.005 mmfd. earth isolating condenser); disconnect the wire from the earth socket to the chassis and insert this condenser.

R20 (47,000 ohms $\frac{1}{4}$ watt pick-up isolating resistor); disconnect the wire from the pick-up socket to the chassis and insert this resistor.

Also a similar resistor should be fitted in place of the wire from C.20 to the other pick-up socket.

When ordering the components for converting the A.C.81 into the D.A.C.81, please quote the following Part Numbers:

S9521 : D.A.C.81 Mains Input Unit.

S9527 : Mains Lead with 2-pin Plug and Socket.

P3767 : C31 .005 Tubular Condenser 450 volt D.C.

P3767 : C32 .005 Tubular Condenser 450 volt D.C.

P9799 : R20, 47,000 ohms $\frac{1}{4}$ watt Resistor (2 required).

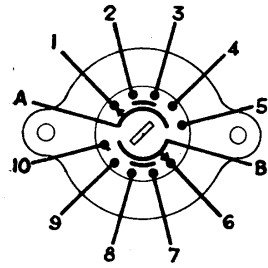

SWITCH SECTIONS.

Switch sections S1 and S2 as viewed from the underside of the chassis, with the sliding contact "A" nearest to the gang condenser.

This illustration shows the position of the contacts on S1 and S2 and will enable the various wires from the coils to the switches to be located.

R.F. COIL DECK CONNECTIONS.

The complete coil deck and switch assembly—Part No. S.9506. For part numbers of the coils, see column under "Coil Data" Table.

The fixing of each coil unit to the deck platform is accessible from the top of the chassis; a hole is provided in the chassis above each coil unit to allow for the removal of the fixing screws. The tag position of each coil is clearly shown in the illustration on the opposite page.

On some chassis holes are only provided above the Oscillator coils and the L.W. Aerial coil, in this case it will be necessary to unscrew the deck platform to replace the S.W. and M.W. Aerial Coils.

For guidance when replacing a coil, it may be noted that the tag connected to the top plate of the trimmer on each oscillator coil, is nearest to the front of the chassis, and on the aerial coils this tag is toward the back of the chassis.

COIL UNIT CONNECTIONS.

| Description of Coil | Tag No. | Inductance | Connection from Tag to :— |
|---------------------|---------|------------|---|
| S.W. Aerial | 2 | L.1, L.2 | Earth braid to gang condenser. |
| " " | 3 | L.1 | Earth tag on switch support. |
| " " | 4 | L.2 | S.1 Contact 1. |
| M.W. Aerial | 1 | L.4 | S.1 Contact 2. |
| " " | 2 | L.3 | L.5 Tag 1 and C.3. |
| " " | 3 | L.4 | R.2, S.1 Contact 4. (C.4 is also joined to this switch contact). L.5 Tag 4. |
| " " | 4 | L.3 | C.1 on A.C.81 chassis. C.31 on D.A.C.81 chassis. C.2. |
| L.W. Aerial | 1 | L.5 | L.3, Tag 2. (C.3 also connected to this tag). |
| " " | 2 | L.6 | S.1 Contact 3. (C.5 is also joined to this switch contact). |
| " " | 3 | L.5 | Earth tag on switch support. |
| " " | 4 | L.6 | L.4, Tag 3. |
| S.W. Oscillator | 2 | L.7 | S.2 Contact 1. |
| " " | 3 | L.8 | C.15. |
| " " | 4 | L.7, L.8 | Earth braid to gang condenser. |
| M.W. Oscillator | 1 | L.10 | C.15 and V.1 pin 6. |
| " " | 2 | L.9 | C.11 and S.2 contact 2. |
| " " | 3 | L.10 | L.12 Tag 3. |
| " " | 4 | L.9 | C.11 and C.14. |
| L.W. Oscillator | 1 | L.12 | S.2, Tag B. |
| " " | 2 | L.11 | S.2 Contact 3, C.12. |
| " " | 3 | L.12 | L.10, Tag 3. |
| " " | 4 | L.11 | C.12, S.2 Contact 4 and C.13. |

COIL DATA.

| Reference | Approx. D.C. Resistance Ohms | Part No. | Spot Colour | Coil Description |
|-----------|------------------------------|----------|-------------|------------------------|
| L.1 | Very small | S.10063 | Green | S.W. Aerial coupling |
| L.2 | Very small | | | |
| L.3 | 0.6 | S.10061 | Green | M.W. Aerial coupling |
| L.4 | 1.8 | | | |
| L.5 | 30 | S.10062 | Green | L.W. Aerial coupling |
| L.6 | 15 | | | |
| L.7 | Very small | S.10066 | Yellow | S.W. Oscillator tuning |
| L.8 | Very small | | | |
| L.9 | 1.6 | S.10064 | Yellow | M.W. Oscillator tuning |
| L.10 | 1.1 | | | |
| L.11 | 2.9 | S.10065 | Yellow | L.W. Oscillator tuning |
| L.12 | 2.4 | | | |
| L.13* | 5.0 | S.9522 | — | 1st I.F.T. Primary |
| L.14* | 5.0 | | | |
| L.15* | 5.0 | S.9523 | — | 2nd I.F.T. Primary |
| L.16* | 5.0 | | | |

* On early serial numbers of the A.C.81 and D.A.C.81 models, the 1st I.F.T. (L.13 and L.14) and the 2nd I.F.T. (L.15 and L.16) are fixed iron core type. Specification as follows :—

L.13, L.14 : D.C. Resistance 3.8 ohms, Part No. S.10057F.

L.15, L.16 : D.C. Resistance 3.8 ohms, Part No. S.9508

WIRING CONNECTIONS TO COIL DECK.

The wiring connections to the complete Coil Deck are as follows:

1. Earth braid from gang condenser to L1 Tag 2.
 2. Earth braid from gang condenser to L8 Tag 4.
 3. S2 contact arm A to VC2 fixed vanes.
 4. S1 contact arm A to VC1 fixed vanes, and to top cap of V1.
 5. L4, Tag 3 to R2.
 6. L3, Tag 4 to C1 (C31 on D.A.C.81 chassis).
 7. L10, Tag 1 to V1 pin 6.
 8. R4 (C8 connected to this tag) to V1 pin 5.
 9. R4 (tag nearest bottom of chassis) to V1 pin 8.
 10. R1 (tag nearest bottom of chassis) to V1 pin 4.
 11. R1 (tag nearest V1) to R17 (tag nearest bottom on chassis).
 12. S1 contact 8 to L.W. Scale lamp.
 13. S1 contact 7 to M.W. Scale lamp.
 14. S1 contact 6 to S.W. Scale lamp.
 15. **D.A.C.81 chassis only:** S1 contact arm B to V3 heater pin 2 (shown X on circuit diagram).
- A.C.81 chassis only:** S1 contact arm B to mains transformer Tag No. 6 (also shown X on circuit diagram).

MAINS TRANSFORMER.

(A.C.81 Model only)

200-250v Type : S.10187 Special, 110, 200-250v Type S10193. Input 230 volts 50 cycles. Mains Tapping Screw in 230v. position

Tag Numbers shown on Circuit Diagram on page 2 and illustration on page 5

| Winding | Tag No. | Approx. D.C. Resistance ohms | A.C. Voltage No load | A.C. Voltage Full load |
|------------------|---------|------------------------------|----------------------|------------------------|
| PRIMARY | | | | |
| Common... | 1 | — | — | — |
| 210v. Tap | 2 | 27* | — | — |
| 230v. Tap | 3 | 30* | — | — |
| 250v. Tap | 4 | 34.5* | — | — |
| SECONDARY | | | | |
| Common... | 5 | — | — | — |
| Scale Lamp Tap | 6 | 0.7 | 4.5 | |
| Valve Heater Tap | 7 | 14.0 | 80 | 72 |
| H.T. Tap | 8 | 220 | 270 | 250 |

* Primary tappings measured from common to each tapping

Primary Magnetising Current

No load approximately : 80 mA. A.C.

Full load approximately : 180 mA. A.C.

THE SPECIAL 110v, 200-250v type has an additional tap for 110v supply mains. Primary D.C. Resistance between common tag 1 and the 110v tap is 15.5 ohms.

VALVE DATA.

A.C.81.

| Valve | Electrode | Pin No. | Mains Supply 230v. A.C. | |
|--|------------|---------|----------------------------|--------------|
| | | | Voltage | Current m.a. |
| V.1 CCH.35 Frequency Changer | Hex. Anode | 3 | 120 | 1.0 |
| | Screens | 4 | 45 | 1.6 |
| | Osc. Anode | 6 | 45 | 1.7 |
| | Cathode | 8 | 0.4 | 4.3 |
| V.2 EF.39 I.F. Amplifier | Anode | 3 | 80 | 3.3 |
| | Screen | 4 | 60 | 1.0 |
| | Cathode | 8 | 1 | 4.3 |
| V.3 EBC.33 2nd Rectifier, A.V.C. and A.F. Amplifier | Anode | 3 | 50 | 0.9 |
| | Cathode | 8 | 1 | 0.9 |
| V.4 CL.33 Output Stage | Anode | 3 | 250 | 29 |
| | Screen | 4 | 120 | 3 |
| | Cathode | 8 | 4.5 | 32 |
| V.5 CY.31 Mains Rectifier | Anode | 5 | 250 A.C. | 42 |
| | Cathode | 8 | 255 | |

VALVE DATA.

D.A.C.81.

www.radio-workshop.co.uk

| Valve | Electrode | Pin No. | Mains Supply 230v. A.C. | | Mains Supply 230v. D.C. | |
|--|------------|---------|----------------------------|--------------|----------------------------|--------------|
| | | | Voltage | Current m.a. | Voltage | Current m.a. |
| V.1 CCH.35 Frequency Changer | Hex. Anode | 3 | 100 | 0.9 | 98 | 0.9 |
| | Screens | 4 | 40 | 1.3 | 38 | 1.3 |
| | Osc. Anode | 6 | 40 | 1.6 | 38 | 1.5 |
| | Cathode | 8 | 0.4 | 3.8 | 0.4 | 3.7 |
| V.2 E.F.39 I.F. Amplifier | Anode | 3 | 70 | 3.1 | 67 | 3.0 |
| | Screen | 4 | 50 | 0.9 | 47 | 0.8 |
| | Cathode | 8 | 1 | 4 | 0.9 | 3.8 |
| V.3 E.B.C.33 2nd Rectifier, A.V.C. and A.F. Amplifier | Anode | 3 | 47 | 0.8 | 43 | 0.8 |
| | Cathode | 8 | 1 | 0.8 | 0.8 | 0.8 |
| V.4 C.L.33 Output Stage | Anode | 3 | 235 | 27 | 215 | 226 |
| | Screen | 4 | 105 | 2.8 | 100 | 2.7 |
| | Cathode | 8 | 4 | 29.8 | 3.7 | 28.7 |
| V.5 CY.31 Mains Rectifier | Anode | 5 | 215 A.C. | 38.5 | 225 | 37 |
| | Cathode | 8 | 240 | | 220 | |

A.C.81 D.A.C.81

Receivers set to Medium waveband with tuning condenser moved to minimum capacity, **No Signal Input.**

All measurements shown using the Universal Avometer No. 7.

Voltage readings with Avometer set to 1,000 volt range, except in the case of cathode voltages, where the 10 volt range is used.

CHASSIS as Negative for H.T. measurements.

All measurements, are approximate.

When the receivers are tuned to a local Broadcasting Station, all current readings on V.1 V.2, and V.3 will show a slight decrease and V.4 an increase.

CIRCUIT ALIGNMENT.

The use of a reputable Modulated Signal Generator with a variable output is essential for accurate line-up of the R.F. and I.F. Circuits.

A suitable dummy aerial should be connected in series with the output lead of the Signal Generator for each Waveband. This may consist of a 400 ohm. non-inductive resistor for the Short Waveband and a fixed condenser of 200 mmfd. for the Medium and Long Wavebands.

When adjusting the I.F. Circuits, a damping unit consisting of a 30,000 ohms non-inductive resistor in series with an 0.05mfd. condenser must be used where indicated.

A sensitive output meter should be used as a visual indicator.

To obtain the most accurate adjustments of the tuned circuit, always use the lowest possible input to the Receiver from the Signal Generator.

Set the Volume Control to maximum and the tone control to low (anti-clockwise).

Check the position of the tuning pointer in relation to the gang condenser, the vanes fully meshed, the centre of the pointer should coincide with the top of the medium and long waveband lines on the scale.

www.radio-workshop.co.uk

OPERATING THE D.A.C.81 RECEIVER ON 100—115 VOLTS SUPPLY.

The D.A.C.81 Receiver is designed to operate on either D.C. or A.C. Mains supply from 180—250 volts (40—80 cycles A.C.).

Where it is necessary to connect the Receiver to a Mains supply of 100—115 volts, the ballast resistor R19 must be reduced to 100 ohms by shortening out the bottom end (tag to V5 heater) to the tag connected to the 220 volt socket, and placing the Mains Voltage plug in the 240 volt socket.

The Filter Resistance R17 (10,000 ohms, 2 watt) must be replaced by a 20 henry 200 ohms smoothing choke type No. P2047, which can be mounted on the chassis.

When operating on a low voltage supply the H.T. line will be less than 100 volts, thereby very considerably reducing the output from the Receiver.

TABLE OF ALIGNMENT PROCEDURE.

| Steps | Connect signal generator to | Connect damping circuit to | Set signal generator to | Tune receiver to | Adjust the following for maximum peak output |
|-------------|---|---|---------------------------|------------------|---|
| I.F.T.'S | | | | | |
| 1 | Control grid of V.2 (top cap) | Anode of V.2 (pin 3) and chassis | 465 Kc/s. | 300 m. | L.16 (secondary 2nd I.F.T.) |
| 2 | " " " " | Detector diode of V.3 (pin 5) and chassis | " | " | L.15 (primary 2nd I.F.T.) |
| 3 | Control grid of V.1 (top cap) | Hexode anode of V.1 (pin 3) and chassis | " | " | L.14 (secondary 1st I.F.T.) |
| 4 | " " " " | Control grid of V.2 (top cap and chassis) | " | " | L.13 (primary 1st I.F.T.) |
| Short wave | | | | | |
| 5 | Sensitive aerial socket (via suitable dummy aerial) | _____ | 18 m. (16.67 mc/s.) | 18 m. | { T.C.4 (oscillator) T.C.1 (aerial) Check calibration |
| | " " " " | _____ | 50 m. (6.00 mc/s.) | 50 m. | |
| Medium wave | | | | | |
| 7 | " " " " | _____ | 300 m. (1,000 Kc/s.) | 300 m. | { T.C.5 (oscillator) T.C.2 (aerial) Check calibration |
| 8 | " " " " | _____ | 500 m. (600 Kc/s.) | 500 m. | |
| Long wave | | | | | |
| 9 | " " " " | _____ | 1,500 m. (200 Kc/s.) | 1,500 m. | { T.C.6 (oscillator) T.C.3 (aerial) Check calibration |
| 10 | " " " " | _____ | 1,900 m. (157.6 Kc/s.) | 1,900 m. | |

CONNECTING GRAMOPHONE PICK-UP AND MOTOR TO D.A.C.81 RECEIVER.

Should hum be experienced when using a Gramophone Pick-up that is provided with screened connecting leads, the following method of connections to the Receiver may be tried:—

Disconnect the screening from any metal parts of the Pick-up arm and connect this screening to the D.A.C.81 chassis. (NOT EARTH SOCKET.)

It is important to cover this Pick-up screening lead with some form of insulation, if not already provided with such protection.

The metal parts of the Pick-up should then be connected to true earth. (EARTH SOCKET.)

The Electric Gramophone Motor casing (or earthing connection on same) must also be joined to true earth. (EARTH SOCKET.)

DISMANTLING.

TO REMOVE CHASSIS—

Disconnect speaker leads from Output Transformer.

Remove the four control knobs from the front of the cabinet.

When replacing, remember to put the felt washers on the control spindles, between the cabinet and the knobs.

Unscrew the two screws securing the top of scale assembly to cabinet.

Remove the four chassis bolts from under the cabinet; the chassis should then be carefully withdrawn from the back.

TO REMOVE SPEAKER—

Disconnect the speaker leads from the Output Transformer.

Remove the nuts and washers from the four bolts holding the speaker to the sub-baffle.

FITTING DRIVE CORD.

Part No: Scale Frame: S.9512.
Drive Wheel and Bracket Scale: P2524
Lamp Holder: S.9152.
Drive Cord, Clip and Spring: S.9513.
(Length of cord (between knots) 36".)
Pointer: S.9514.

First remove the glass scale by unscrewing the four fixing screws.

Turn the drive wheel into the position that will bring the gang condenser to minimum capacity.

The illustration shows clearly the procedure of the cord on the drive wheel and pulleys.

It is only necessary to emphasise that the back turn of the cord should be placed on the drive wheel first.

When the cord is in position, as shown in the illustration, the drive wheel should be turned until the gang condenser is at maximum capacity, when the centre line of the pointer should coincide with the top of the medium and long wavelength lines.

The pointer is detachable, and may be placed in position on the cord by gently easing over two small clips on the back.

REPLACEMENT OF SCALE LAMPS.

A.C.81 Receiver—

Three 6.2 volts, 0.3 amp. lamps are fitted; a lower voltage should not be used.

D.A.C.81 Receiver—

The lamps fitted are 6.2 volts, 0.3 amp. Whereas variation of voltage of each lamp is immaterial, IT IS ESSENTIAL that the current taken by any replacement lamp should be 0.3 amps.

To replace the scale lamps, unscrew the knurled nuts behind the scale assembly and withdraw with care the panel containing the three lamps.

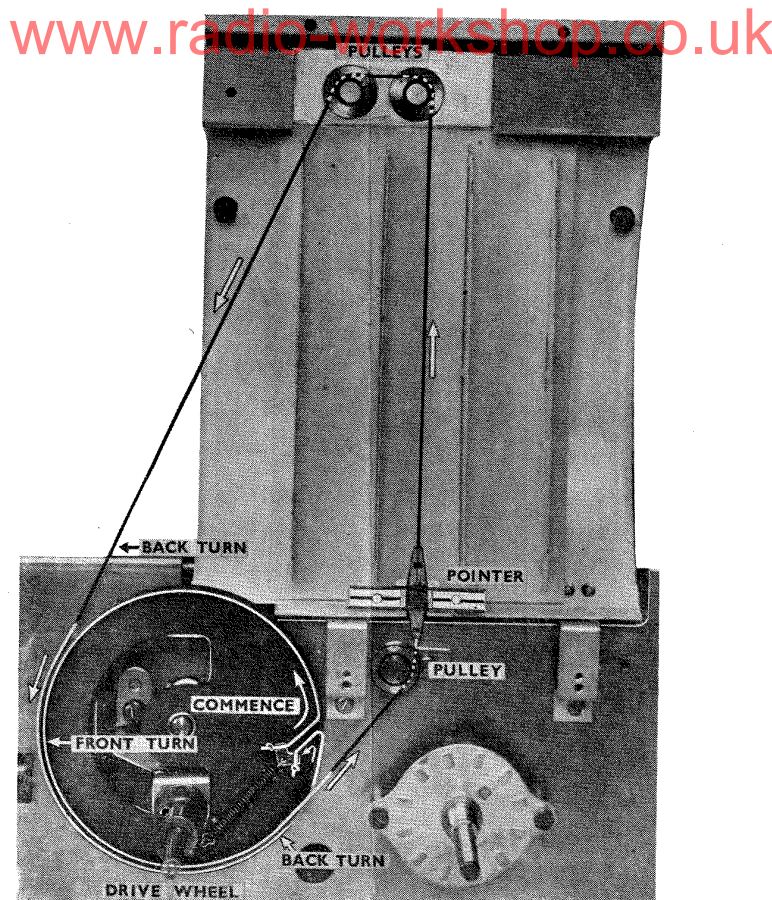

A.C.81, D.A.C.81 Tuning Drive

SPEAKER.

Type: Rola 8-Z, 6.5 pmm. Permanent Magnet or Celestion p.m. 1010.

Speech Coil D.C. Resistance: 2.5 ohms.

Leads from speech coil taken direct to terminals on output transformer, Nos. 2 and 3.

OUTPUT TRANSFORMER.

PART No. S9510.

Connections to Output Transformer:

Tag numbers shown on Circuit Diagram on page 2 and illustration on page 5.

Tag No. 1—H.T. (unsmoothed).

Terminal No. 2—INT. Speaker plug.

Terminal No. 3 EXT. Speaker socket (bottom socket).

Tag No. 4—INT. Speaker socket.

Tag No. 5—Anode of V4.

D.A.C.81 MAINS SUPPLY UNIT.

The mains supply unit used on the D.A.C.81 chassis consists of a metal panel secured to the chassis by means of four fixing screws, in place of the mains transformer used on the A.C.81 chassis. Upon this panel is mounted the mains choke assembly, 2 pin plugs (connection to the mains lead), and the tapping panel holding the ballast resistor. The complete unit is covered by Part No. S9521. Full details are given for fixing this under the section entitled "CONVERSION OF RECEIVER A.C.81 to D.A.C.81" on page 3 of this manual.

D.A.C.81 MAINS R.F. CHOKES.

Type: S9013.

D.C. Resistance: Each 6 ohms.

Mains connector Pins: Standard 5 amp. type.

Mains lead with 2-pin plug and socket: S9527.

CIRCUIT DESCRIPTION.

AERIAL CIRCUIT—

Aerial input on selective tap via C1 (and isolating condenser C31 on D.A.C.81 only), via C2 on S.W. only, to L1 (S.W.), L3 (M.W.) and L5 (L.W.). The tuned aerial circuit consists of L2, TC1 (S.W.), L4, TC2 (M.W.), and L6, T.C.3, C5 (L.W.) tuned by VC1.

On the S.W. position, the coils L4 (M.W.) and L6 (L.W.) are shorted and on the M.W. position L6 (L.W.) is shorted.

FREQUENCY CHANGER—V1, Mullard CCH.35—

The hexode control grid is fed from the tuned aerial circuits and is AVC controlled, R2 and C4 forming the decoupling circuit. R1 and C6 provide the decoupling for the screening grids and triode oscillator anode. On S.W. the oscillator anode is taken direct to the H.T. line via L10, L12; on M.W. and L.W. it is fed from R1. The cathode bias by R3 with C7 as by-pass.

The beat frequency is obtained by coupled coils L7, L8 (S.W.), L9, L10 (M.W.), and L11, L12 (L.W.). The S.W. reaction coil L8 is fed from the oscillator anode by C15.

On S.W. the hot end of the L9 (M.W.) and L11 (L.W.) are connected together; on M.W. the coil L11 (L.W.) is shorted.

Parallel trimming of the oscillator grid circuit by TC4 (S.W.), TC5, CH (M.W.) and TC6, C12 (L.W.).

Padding by C14 (M.W.) and C13 (L.W.). C8 is the oscillator grid condenser, and the grid return R4 is taken to the cathode.

In the anode circuit of the hexode section of V1 is the primary L13 of the first I.F. Transformer, the secondary L14 is fed via R5 to the control grid of V2.

The primary and secondary are turned by variable iron cores.

INTERMEDIATE FREQUENCY AMPLIFIER — V2 Mullard EF.39—

This valve operates as an I.F. Amplifier on a frequency of 465 Kc/s with AVC.R6, C19 forming the decoupling circuit.

The screen grid is decoupled by R7, C16 and the anode by R8, C17.

Cathode bias by R12, C24 common from V3 cathode. The second I.F. Transformer L15 (primary) and L16, (secondary) forms the coupling to V3.

Tuning of the I.F. Transformer by variable iron cores.

SIGNAL RECTIFIER, AVC RECTIFIER and A.F. AMPLIFIER—V3, Mullard EBC.33—

The signal rectifier anode is fed direct from the hot end of L16 (secondary second I.F. Transformer) through C22. The signal voltage developed across VRI (manual volume control), the bottom end of which is taken to the cathode potential, is fed via C23 and R9 to the triode control grid; R10 is the grid return resistance.

The gramophone pick-up input is applied to the top end of VRI and chassis. On the D.A.C.81 chassis it is isolated by R20 which is also used to apply a negative bias to the signal diode.

The AVC rectifier anode is fed from a tap on L15 (Primary second I.F. Transformer) via C22; a D.C. potential is developed across R13 and fed back through decoupling circuits as negative bias to V1 and V2, giving automatic volume control. Delay voltage is obtained from the drop along V3 cathode bias R12. I.F. by-pass by C24.

Resistance capacity coupling R11, C26, R14, R15 is employed to couple the triode anode of V3 to the control grid of V4. I.F. by-pass of V3 anode C25.

OUTPUT STAGE—V4 Mullard CL.33—

Negative feedback is applied to the output valve. R16 the cathode resistance is used to apply the correct amount of feedback, carrying the D.C. component of the anode current and also the signal current, producing a voltage in opposition to the grid input. The potential applied to the screen of V4 is lower than the anode as it is taken from the smoothed side of R17. On a strong signal, the voltage drop along the H.T. line is reduced as the AVC produces an increase in negative bias to V1 and V2, thus reducing the total H.T. current taken by these valves, with the result that the screen potential of V4 rises, enabling this valve to handle a larger output.

The anode of V4 via the output transformer is taken direct to the cathode of the mains rectifier.

Variable tone control VR2, C27 in the anode circuit of V4.

Provision is made for connecting a low impedance external speaker across the secondary of the output transformer and of disconnecting the internal permanent magnet speaker.

H.T. RECTIFIER—V5 Mullard CY.31—

This is a half-wave rectifier used to supply the H.T. line; a surge resistor R18 is in the anode circuit. R.F. by-pass by C30.

Resistance filtering of the H.T. line by R17 and C28, reservoir condenser C29.

A.C.81 CHASSIS—

The A.C. supply is obtained by a single secondary winding on the mains transformer with tapplings for the rectifier anode, valve heater (wired in series) and the scale lamps.

D.A.C.81 CHASSIS—

The rectifier is wired as in the A.C. Model and its function is the same; on D.C. supply mains the emission from the cathode to the anode offers a low resistance D.C. path.

The heaters of all valves and the scale lamps are wired in series with a ballast resistor R19 tapped for 200 to 240 volt supply. The air-cored chokes in each lead of the supply mains with C30 form the R.F. filter circuit.

FAULTS TABLE.

This Table does not cover Valve failures or obvious faults which should be simple to locate :—

| Symptoms | Possible Causes | Check |
|---|---|---|
| NO RESULTS All Wavebands | Mains Rectifier Circuit and H.T. Line | D.A.C.81 : R.17, R.18, R.19, S/C in C.28, C.29, C.30 will O/C R.18. A.C.81 : Mains Transformer windings, R.17, R.18, C.30, S/C in C.28, C.29. |
| Output Stage | Output Circuit of V.4 Cathode Circuit Grid Circuit Tone Correction | Int. Speaker plug disconnected. Output transformer windings O/C. R.16 O/C. R.15, C.26 O/C. If C.27 S/C and V.R.2 turned to low the output transformer primary will be S/C. |
| A.F. Stage | Anode Circuit of V.3 Cathode Circuit Grid Circuit Diode Rectifier Circuit | R.11, C.25. R.12 (common to V.2 cathode). R.9, C.23, V.R.1. L.16 O/C ; C.20, C.21 S/C. |
| I.F. Amplifier | Anode Circuit Screen Feed Grid Circuit | L.15, R.8 O/C ; C.17, C.18 S/C. R.7 O/C ; C.16 S/C. R.5, R.6, L.14 O/C ; C.10 S/C. |
| Frequency Changer... .. | Feed to Screens and Oscillator Anode Oscillator Grid Circuit Cathode Circuit Hexode Anode Circuit | R.1 O/C, C.6, C.15 S/C. Switch S.2 moving contact A faulty. C.8 O/C, V.C.2 S/C. Switch S.2 moving contact B faulty. R.3 O/C. L.13 O/C ; C.9 S/C. Check alignment of 1st and 2nd I.F. Transformers. |
| Aerial Circuits | Gang Condenser Aerial isolating condenser on D.A.C.81 | V.C.1 S/C. Switch S.1 moving contacts A and B faulty. C.13 O/C. |

FAULTS TABLE.
(Continued)

| | | |
|---|---|--|
| WEAK SIGNALS (All Wavebands) | Voltages on Valves | Check all valve voltages from the Valve Data Table on Page 6. R.15, R.14, C.26, C.25, R.11, R.9, C.23, V.R.1. See Alignment Instructions on Page 7. |
| | A.F. Circuits of V.3, V.4 I.F. Circuits out of alignment. (This would cause poor selectivity) Decoupling and by-pass condensers A.V.C. Line Switch Contacts | C.6, C.7, C.24. R.13, R.6, C.19, R.2, C.4. S.1, S.2. |
| | S.W. only | Aerial : C.2, L.1, L.2, T.C.1, S.1, contact 1 and bar shorting 2 and 3. Osc. : T.C.4, L.7, L.8, C.15, S.2, contact 1, bar shorting 2 and 3. |
| | M.W. only | Aerial : L.3, L.4, T.C.2, S.1, contact 2 and bar shorting 3 and 4. Osc. : C.11, T.C.5, L.9, L.10, C.14. S.2 contact 2 and bar shorting 3 and 4. |
| L.W. only | Components associated with L.W. Circuit | Aerial : C.3, L.5, L.6, T.C.3, C.5, S.1, Contact 3. Osc. : C.12, T.C.6, L.11, L.12, C.13. S.2, contact 3. |
| CALIBRATION INCORRECT (All Wavebands) | Scale Reading | Check pointer position in relation to tuning scale, see paragraph under "Fitting Drive Cord" on Page 8. Re-align on 465 Kc/s., according to instructions on Page 7. |
| | I.F. Circuits incorrect frequency... | |
| | S.W. only | Tuning—T.C.4. |
| | M.W. only | Tuning—T.C.5, C.11. Padding—C.14. |
| | L.W. only | Tuning—T.C.6, C.12. Padding—C.13. |
| INSTABILITY | Cathode by-pass condensers | C.7, C.24. |
| | Decoupling Condensers Earthing of Screened Leads Poor contact on valve pins | C.6, C.16, C.17. From C.23 to R.9. From C.27 to V.R.2. |
| DISTORTION | Voltages on Valves incorrect | Check with " VALVE DATA " on Page 6. |
| | A.F. Coupling Condensers V.3 Signal Diode Circuit components A.V.C. Line Cathode bias on V.3, V.4 | C.23, C.26. C.20, V.R.1, R.10. C.22, R.13, R.6, C.19, R.2, C.4. R.12, R.16. |
| HUM | Smoothing | R.17, C.28, C.29. |
| | Volume Control Earthing of screened leads See under Section dealing with " Pick-up and Motor " on Page 7 | V.R.1. To V.R.1 and V.R.2. |
| HUM USING A PICK-UP | | |

BUSH RADIO LTD.

POWER ROAD, LONDON, W.4

Telephone: CHlswick 6491/9

BUSH RADIO

MODIFICATION SHEET

MODELS A.C.81 and D.A.C.81

THIS SERVICE SHEET SHOULD BE USED IN CONJUNCTION WITH THE
A.C.81. AND D.A.C.81. ISSUE

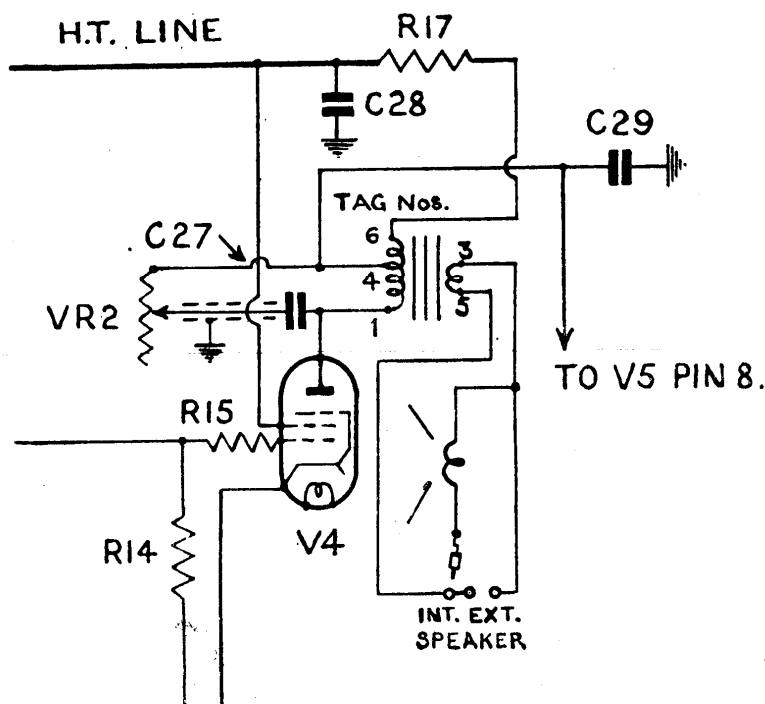

Circuit Diagram of A.C.81 and D.A.C.81 Output Stage showing connections of the new type of output transformer.

OUTPUT TRANSFORMER MODIFICATION

A modified output transformer, with a tapped primary winding, has been fitted to later models of the A.C.81. and D.A.C.81. receivers, commencing with serial numbers 15101 (A.C.81.) and 4651 (D.A.C.81.).

The unsmoothed H.T. from the rectifier cathode is introduced at the tap on the primary winding, the start and finish of which is connected to the anode of V.4. and R.17.

The tone control is connected between the primary tap and the output valve anode.

Facing the back of the chassis and reading from left to right, the wiring connections from the tags are as follows:—

- | | |
|---------------------------------------|--|
| Tag No. 1. | Yellow lead—V.4. anode (pin 3). |
| " " 2. | Light Green lead—Internal speaker cut-out plug; the speech coil is also connected to this tag. |
| " " 3. | Green lead—Lower External Speaker socket, the speech coil is also connected to this tag. |
| " " 4. | Red lead—C.29. |
| " " 5. | Green lead—Internal speaker socket. |
| " " 6. | Yellow/Red lead—R.17. |
| Part number of output transformer ... | S.12685 |
| Ratio— | 60.6 : 1. |
| D.C. Resistance—Primary | { Start to Tap—180 ohms. |
| | { Tap to Finish—20 ohms. |
| | Secondary—0.25 ohms. |

ALTERATION TO H.T. RECTIFIER FEED IN THE D.A.C.81. RECEIVER

On later models of the D.A.C.81. the H.T. Rectifier valve has its anode connection taken (via R.18.) to the 220 volt tapping of the heater ballast resistor

(R.19.), instead of the 240 volt tapping as shown in the circuit diagram on page 2 of the A.C.81. and D.A.C.81. Service Manual.

OPERATING THE D.A.C.81. RECEIVER ON 100—115 VOLT SUPPLY

Reference—On page 7 of the A.C.81. and D.A.C.81. Service Manual. Choke recommended to replace R.17.

(10,000 ohms) Part No. P.2047 is now Part No. S.12883, and this number should be quoted when ordering.