

BUSH RADIO

Service Instructions

A.C. MODEL—A.C.1

A.C.-D.C. MODEL—D.A.C.1

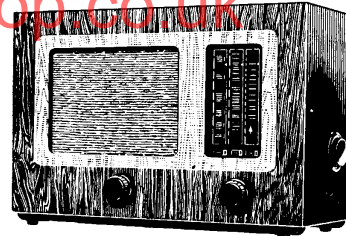

Front View of Receiver

INDEX.

Section	Page	Section	Page
Capacitors	3	Resistors... ..	3
Capacitors, variable	4	Servicing notes	8
Circuit alignment	8	Speaker	6
Coil data... ..	4	Specification	1
Coil connections	7	Valve data	4
Connections to output transformer	6	Warning	7
Dismantling	7	Modification	8
Fitting wire drive	7	<i>Illustrations :—</i>	
Mains transformer	4	Under chassis view of A.C.1	5
Mains input circuits	6	Top view of chassis... ..	6
Output transformer	6	End view showing wire drive	7
Part Numbers	8		

SPECIFICATION.

BASIC DESIGN.

A five-valve, including rectifier, three waveband, super-heterodyne receiver with six tuned circuits.

The A.C. model (A.C.1) employs an auto-transformer with tapings to supply the scale lamp, H.T. line and valve heaters, the latter being connected in series.

The A.C./D.C. model (D.A.C.1) is the same as the A.C. version with the exception of a ballast resistor, which replaces the auto-transformer, and the 6.2 V. 0.3 A. scale lamp wired in series with the valve heaters.

VALVES.

Mullard	CCH.35	...	Heater	7.0 V., 0.2 A.
"	EF.39	...	"	6.3 V., 0.2 A.
"	EBC.33	...	"	6.3 V., 0.2 A.
"	CL.33	...	"	33.0 V., 0.2 A.
"	CY.31	...	"	20.0 V., 0.2 A.

All valves have international octal bases.

SCALE LAMP.

A.C. Model—3.5 V., 0.3 A.

A.C./D.C. Model—6.2 V., 0.3 A.

VOLTAGE RANGE.

A.C. Model—100–120 and 200–250 volts, 40–100 cycles.

A.C./D.C. Model—200–250 volts.

MAINS CONSUMPTION.

A.C. Model ... approx. 32 watts with 230 volts input.

A.C./D.C. Model ... approx. 60 watts with 230 volts input.

AUDIO OUTPUT.

Approximately 1.5 watts.

INTERMEDIATE FREQUENCY.

465 Kc/s.

WAVEBAND RANGES.

Long 850–2000 metres (352.9 Kc/s.—150.0 Kc/s.)

Medium 170– 560 metres (1.76 Mc/s.—535.7 Kc/s.)

Short 16– 50 metres (18.75 Mc/s.— 6.0 Mc/s.)

CONTROLS.

Facing front of receiver, from left to right :

On/Off switch and volume control.

Waveband switch.

Tuning—On right side of cabinet.

AERIAL AND EARTH.

Two aerial sockets are provided. The top socket is the normal position for the aerial giving "Maximum Sensitivity." The centre socket is an alternative position if interference is experienced from a powerful local transmitter or when a long aerial is used. This socket is used for "Maximum Selectivity."

The bottom socket is for the earth connection and no direct earth should be made to any other part of the chassis.

CABINET DIMENSIONS.

Length 20 $\frac{3}{8}$ ins. Height 13 $\frac{1}{4}$ ins. Depth 9 $\frac{1}{8}$ ins.

WEIGHT.

Approximately 18 ins.

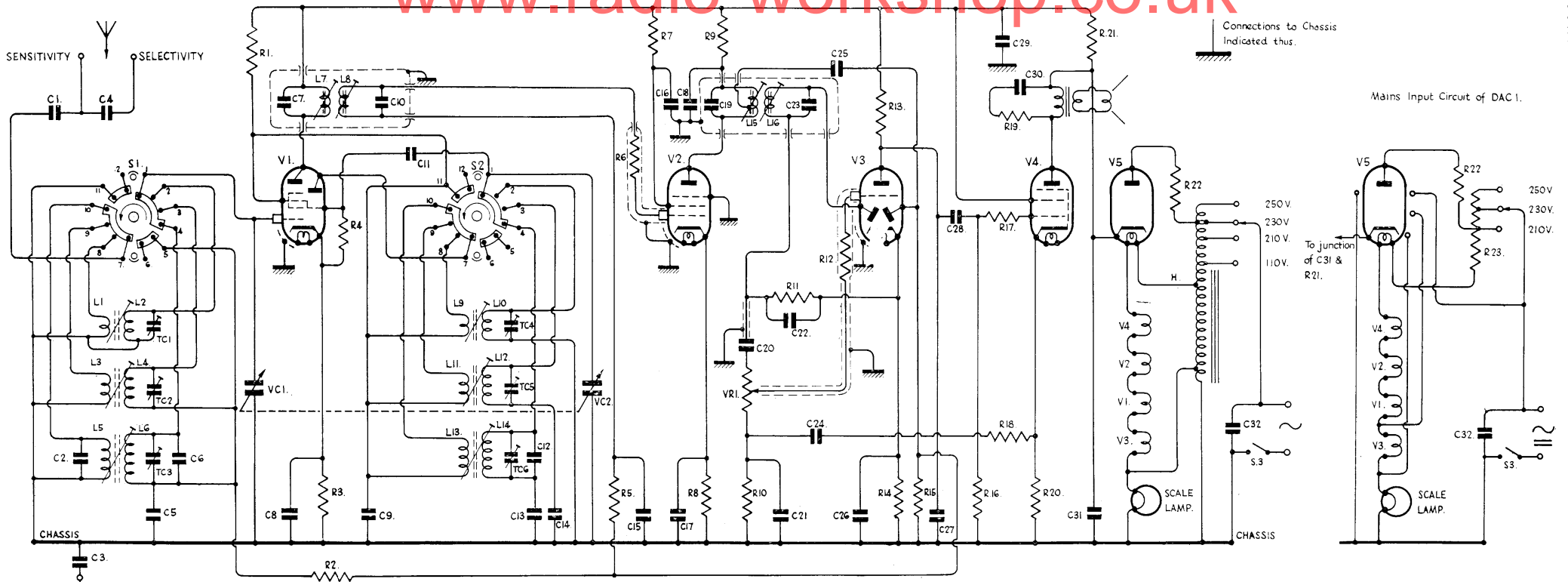

The pin connections are shown as they appear when the base or its holder is viewed from the underside of the chassis.

AC.I. & DAC.I.

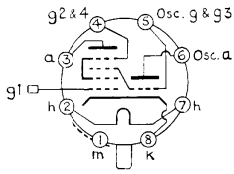

V1
CCH 35

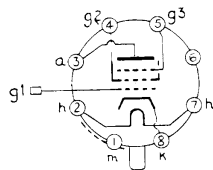

V2
EF 39

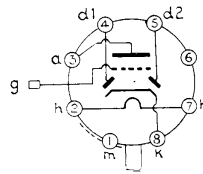

V3
EBC 33

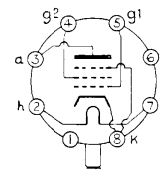

V4
CL 33

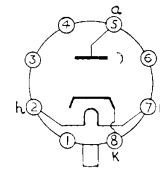

V5
CY 31

CAPACITORS.

Ref.	Value		Tolerance ± %	Type	D.C. Working Voltage	Part No.	Description
	mfd.	mmfd.					
C. 1	·005	—	20	Tubular	500	P 3767 or P12666	Aerial isolating capacity. L.W. aerial shunt.
C. 2	—	800	20	Mica	350	P 3776	
C. 3	·05	—	20	Tubular	500	P 8935 P 8997	True earth isolating capacity. Series aerial capacity.
C. 4	—	50	10	Silvered Mica	350	P 3779	
C. 5	·05	—	20	Tubular	350	P 3770 or P12363	V.1 A.V.C. decoupling. L.W. parallel capacity.
C. 6	—	30	10	Silvered Mica	350	P 3778	
C. 7	—	110	2	" "	350	P 3729	1st I.F.T. primary capacity. V.1 Cathode decoupling.
C. 8	·05	—	20	Tubular	350	P 3770 or P12363	
C. 9	·05	—	20	" "	350	P 3770 or P12363	V.1 Screens and oscillator anode decoupling. 1st I.F.T. secondary capacity.
C.10	—	110	2	Silvered Mica	350	P 3729	
C.11	—	50	20	Mica	350	P 3774	V.1 oscillator grid capacity. L.W. oscillator grid coil parallel capacity.
C.12	—	180	2	Silvered Mica	350	AP13329	
C.13	—	390	1	" "	350	P12961	L.W. fixed padding. M.W. fixed padding.
C.14	—	556	1	" "	350	P 2034	
C.15	·05	—	20	Tubular	350	P 3770 or P12363	V.2 A.V.C. decoupling. V.2 Screen decoupling.
C.16	·05	—	20	" "	350	P 3770 or P12363	
C.17	·01	—	25	" "	350	P 3769 or P12773	V.2 Cathode decoupling. V.2 Anode decoupling.
C.18	·05	—	20	" "	350	P 3770 P12363	
C.19	—	110	2	Silvered Mica	350	P 3729	2nd I.F.T. primary capacity. Coupling to V.3 control grid.
C.20	·01	—	25	Tubular	350	P 3769 or P12773	
C.21	0·1	—	20	" "	350	P12943	Part of feedback circuit. I.F. Filter.
C.22	—	100	20	Mica	350	P 3775	
C.23	—	110	2	Silvered Mica	350	P 3729	2nd I.F.T. secondary capacity. Part of feedback circuit.
C.24	·05	—	20	Tubular	350	P 3770 or P12363	
C.25	—	50	20	Mica	350	P 3774	Coupling to A.V.C. diode. V.3 Cathode decoupling.
C.26	50	—	—	Electrolytic	12	P12662 or P12962	
C.27	·006	—	25	Tubular	350	P12776 or P12987	Fixed tone corrector. Coupling to V.4 control grid.
C.28	·01	—	25	" "	350	P 3769 or P12364	
C.29	16	—	—	Electrolytic	275	P12444	H.T. line smoothing. Fixed tone corrector.
C.30	·01	—	25	Tubular	350	P 3769 or P12364	
C.31	32	—	—	Electrolytic	275	P12444	H.T. line smoothing. Mains R.F. by-pass.
C.32	0·1	—	20	Tubular	500	P12943	

Note.—C.29 and C.31 are in one container.

RESISTORS.

Ref.	Value in ohms.	Rating watts.	Part No.	Description
R. 1	15,000	—	P6652	V.1 Screens and oscillator anode decoupling.
R. 2	1 meg.	—	P7115	V.1 A.V.C. decoupling.
R. 3	100	—	P6107	V.1 Cathode bias.
R. 4	33,000	—	P6737	V.1 Oscillator grid resistor.
R. 5	2·2 meg.	—	P7199	V.2 A.V.C. decoupling.
R. 6	220	—	P6191	V.2 Control grid stabiliser.
R. 7	47,000	—	P6779	V.2 Screen decoupling.
R. 8	220	—	P6191	V.2 Cathode bias.
R. 9	10,000	—	P6611	V.2 Anode decoupling.
R.10	4,700	—	P6527	Part of feedback circuit.
R.11	330,000	—	P6989	I.F. Filter.
R.12	100,000	—	P9389	V.3 Control grid stabiliser.
R.13	68,000	—	P6821	V.3 Anode load.
R.14	1,000	—	P6359	V.3 Cathode bias.
R.15	1 meg.	—	P7115	V.3 A.V.C. diode load.
R.16	470,000	—	P7031	V.4 Control grid resistor.
R.17	47,000	—	P6779	V.4 Control grid stabiliser.
R.18	2,200	—	P6443	Part of feedback circuit.
R.19	10,000	—	P6610	Fixed tone corrector.
R.20	150	—	P6155	V.4 Cathode bias.
R.21	10,000	2	P6608	H.T. line smoothing.
R.22	150	1	P6147	V.5 Surge limiter.
R.23	600 ± 100 ± 100	30	P3764	D.A.C.1 only. Heater circuit ballast.
V.R.1	2 meg.	—	CP13375	Volume control.

Note. A tolerance of ± 20% is permissible on all resistors with the exception of R.20 ± 10%.

Owing to supply difficulties it may be found that the colour coding of some resistors does not correspond with the value shown in the above Table. The measured value of the component fitted, however, will come within the tolerance of the specified resistance.

A.C.1 & D.A.C.1

VARIABLE CAPACITORS.

Ref.	Value mmfd.	Type	Part No.	Description
V.C.1	533	Ganged Condenser	P12422	{ Aerial circuit tuning. Oscillator circuit tuning.
V.C.2	533			
T.C.1	3-40	" Postage stamp "	P2937A	S.W. Aerial coil trimmer.
T.C.2	3-40	" "	"	M.W. Aerial coil trimmer.
T.C.3	3-40	" "	"	L.W. Aerial coil trimmer.
T.C.4	3-40	" "	"	S.W. Oscillator grid coil trimmer.
T.C.5	3-40	" "	"	M.W. Oscillator grid coil trimmer.
T.C.6	3-40	" "	"	L.W. Oscillator grid coil trimmer.

www.radio-workshop.co.uk

COIL DATA.

Ref.	Approx. D.C. resistance in ohms	Part No.	Description
L. 1	Under 1/2 ohm.	S12733	S.W. Aerial coupling.
L. 2	" " "		S.W. Aerial tuning.
L. 3	0.6 "	S12737	M.W. Aerial coupling.
L. 4	4.0 "		M.W. Aerial tuning.
L. 5	32.0	S12739	L.W. Aerial coupling.
L. 6	16.0		L.W. Aerial tuning.
L. 7	5.0	S12680	1st I.F.T. primary.
L. 8	5.0		1st I.F.T. secondary.
L. 9	Under 1/2 ohm.	S12733	S.W. Oscillator coupling.
L.10	" " "		S.W. Oscillator tuning.
L.11	0.6 "	S12738	M.W. Oscillator coupling.
L.12	3.2 "		M.W. Oscillator tuning.
L.13	1.5	S12740	L.W. Oscillator coupling.
L.14	4.0		L.W. Oscillator tuning.
L.15	5.0	S12683	2nd I.F.T. primary.
L.16	5.0		2nd I.F.T. secondary.

A.C.1

VALVE DATA.

Input 230 volts A.C. 50 cycles.

Receiver set to medium waveband with no signal output.

All measurements taken on Avometer Model 7 with chassis negative ; 1000 volt range for H.T. and 10 volt (or appropriate) range for cathode measurements.

Valve	Electrode	Pin No.	Voltage	Current
V.1	Hexode Anode	3	115	5.5 mA.
	Oscillator Anode	6	59	
	Screens	4	59	
	Cathode	8	0.4	
V.2	Anode	3	84	4.6 mA.
	Screen	4	57	
	Cathode	8	0.85	
V.3	Triode Anode	3	40	1.0 mA.
	Cathode	8	0.75	
V.4	Anode	3	265	30.0 mA.
	Screen	4	115	
	Cathode	8	4.3	
V.5	Anode	5	225AC	41.5 mA.
	Cathode	8	270	

D.A.C.1

Voltages on the D.A.C.1 receiver on A.C. mains will be approximately the same as the A.C.1, but slightly less on the equivalent D.C. mains.

MAINS TRANSFORMER.

(A.C.1 only.)

Part Number S12708. Auto-transformer.

Input 230 volts 50 cycles. Mains adjusting screw in 230 volts position.

Winding	Tag	Approx. D.C. resistance	A.C. Voltage No load	A.C. Voltage Full load
Start of winding to :—	E	—	—	—
110 V. tap	110	87.0 ohms	118	110
210 V. tap	210	165.0 "	210	210
230 V. tap	230	180.0 "	230	230
250 V. tap	250	200.0 "	250	250
3.5 V. tap	DL	2.2 "	3.2	2.7
Heater tap	H	59.0 "	78	70

Magnetising current approx. 60mA.
Current on full load approx. 150mA.

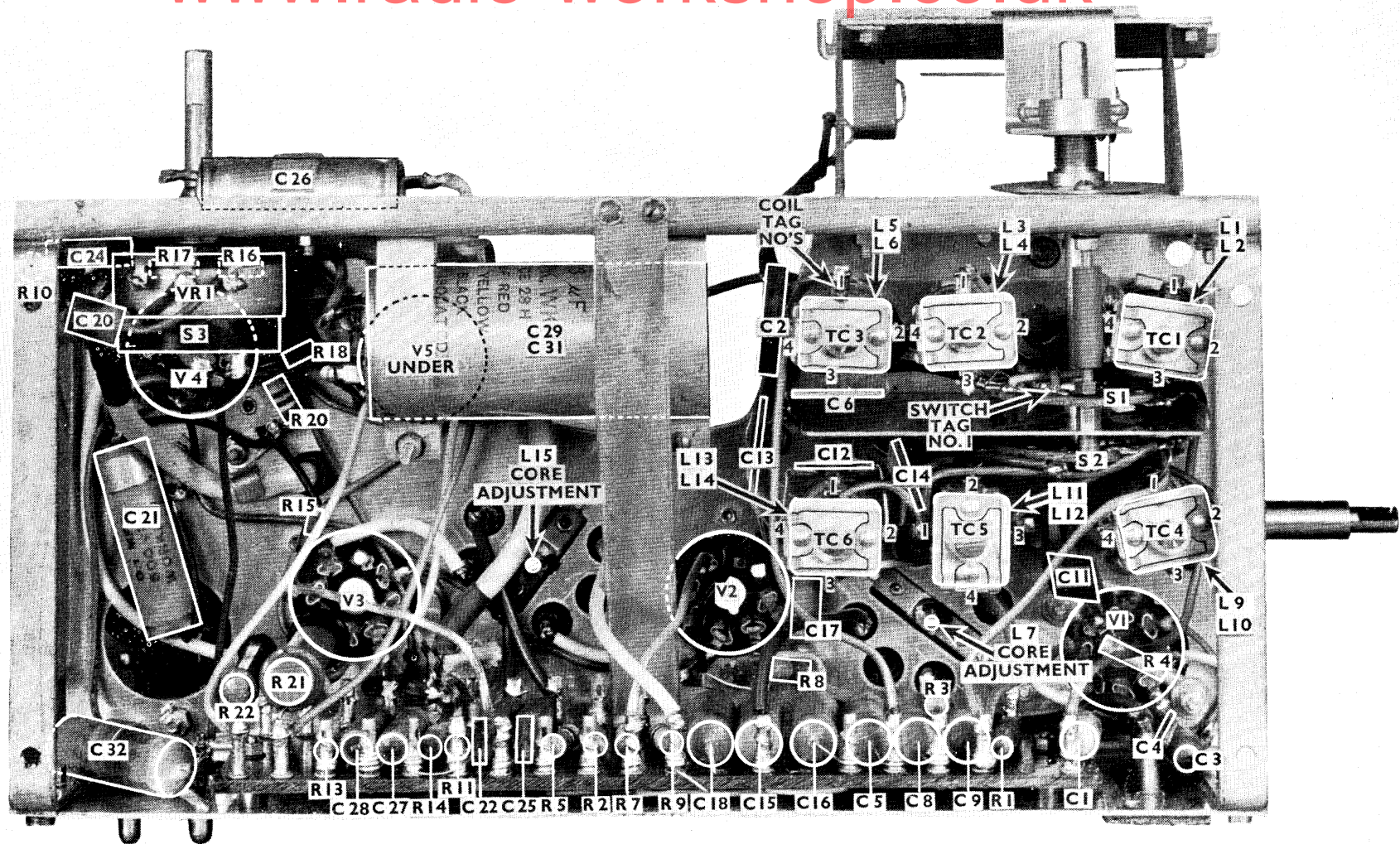

Under chassis view of receiver

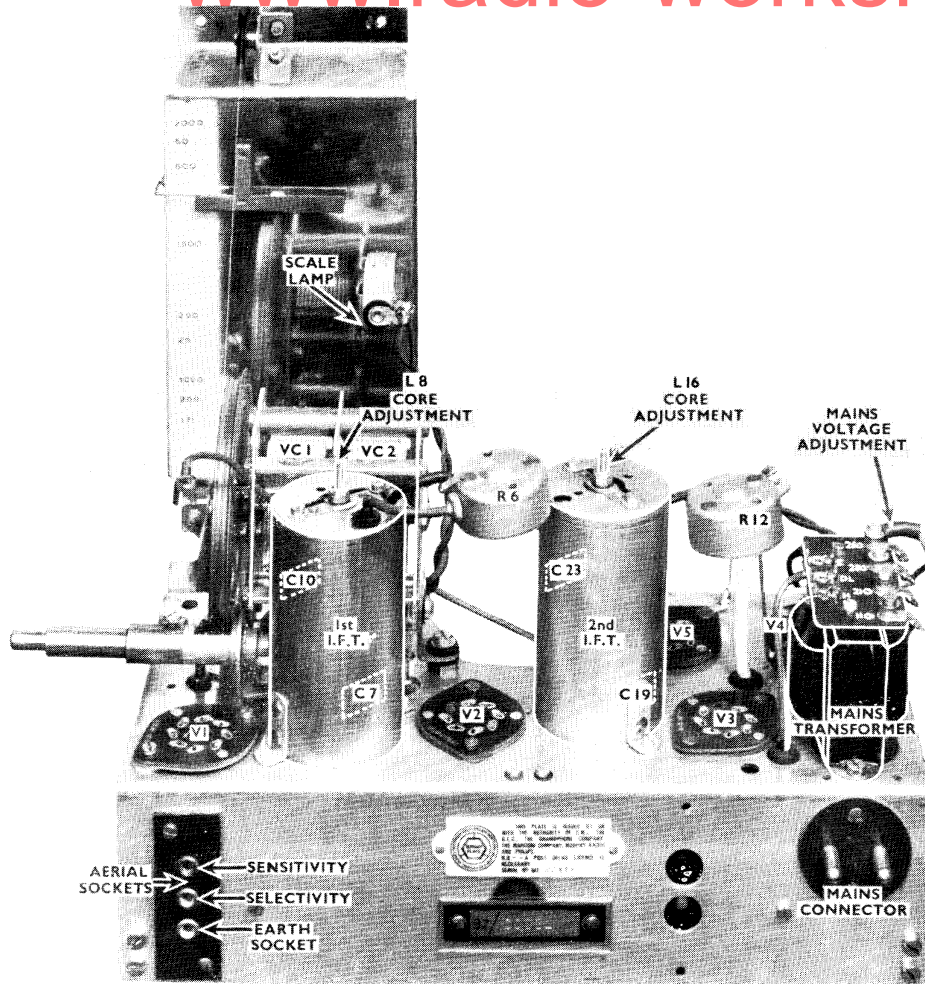

Top view of chassis.

(The D.A.C.1 receiver has a mains ballast resistor in place of the mains transformer shown above).

A.C.1 AND D.A.C.1 MAINS INPUT CIRCUITS.

The mains input units of the A.C.1 and D.A.C.1 receivers are not interchangeable as may appear from the circuit diagram. Each receiver is made specifically either for A.C. mains only or for universal (A.C. and D.C.) operation.

OUTPUT TRANSFORMER.

Part No. BS15432
 D.C. resistance :
 Primary 500 ohms.
 Secondary 0.5 ohms.
 Ratio : 54.8 : 1.
 Primary inductance, at 400 cycles 5 V. (No load on sec.)
 is 6.4 henrys with 26 mA. D.C. flowing.

SPEAKER.

Part No. P3292 or AP15140
 Type 8 ins. Celestion or Rola.
 Speech Coil impedance approximately 2.5 ohms.
 „ „ D.C. resistance approximately 2.0 ohms.

CONNECTIONS TO OUTPUT TRANSFORMER.

Viewing the output transformer from the back of the receiver, the tags are numbered 1, 2 and 3 on the left-hand side and 4 and 5 on the right-hand side.

- Tag No. 1, Primary, to C30 and V4 pin 3.
- „ „ 2, to C30 and R19.
- „ „ 3, Primary, to R19 and C31.
- „ „ 4, Secondary to speaker speech coil.
- „ „ 5, Secondary to speaker speech coil.

REPLACEMENT OF SCALE LAMP.

To replace the scale lamp, press the sides of the holder and withdraw the clips from the slots in the scale frame. Unscrew the lamp and replace with a 3.5 V., 0.3 A., type for model A.C.1 or 6.2 V., 0.3 A., for model D.A.C.1. Screw the lamp firmly into its holder.

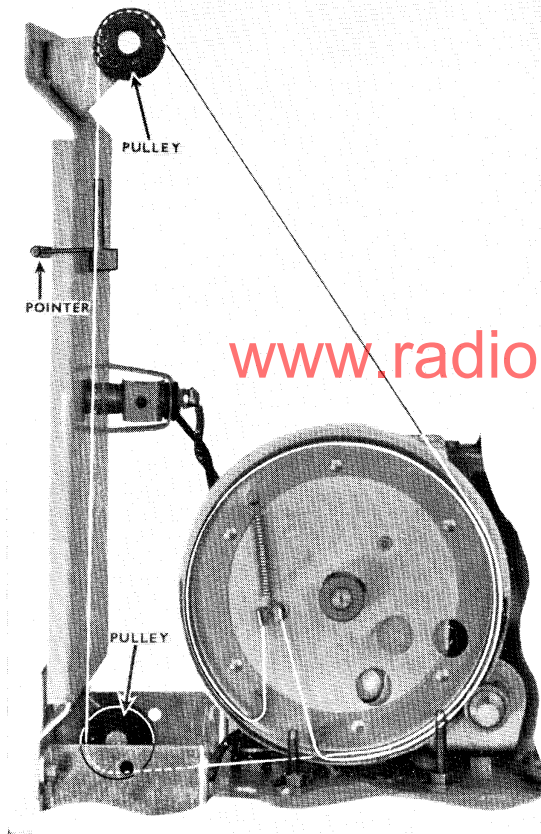

View showing wire drive.

FITTING WIRE DRIVE.

The length of wire after clenching the ends in the anchor is 33 $\frac{3}{4}$ ins.

Remove the back bracket supporting the pulley mounting plate. Detach the pointer from the wire by raising the securing lugs on the back of the pointer.

Hook the anchor to one end of the drive pressure spring the other end of which is attached to the hook in the drum drive. Pass the wire round the drum anticlockwise for half a turn, over the top pulley, and behind the pulley mounting plate to the lower pulley. Take the wire round the pulley then round the drum once in an anticlockwise direction back to the anchor and spring. Turn the variable condenser until the plates are fully meshed and attach the pointer to the wire so that it is in line with the marks at the extreme top of the calibration scale.

Clamp the securing lugs of the pointer to the wire.

Replace the back bracket.

WARNING.

When servicing this receiver remember that one side of the mains is connected directly to the chassis and may, under certain conditions, be "live."

Do not connect any earthed equipment or a direct earth

to the chassis without first isolating it by a capacitor of approximately .005 mfd.

Care should be taken to avoid handling the chassis.

DISMANTLING.

Disconnect the aerial, earth and mains connection from the receiver.

Remove the back of the cabinet.

Remove the tuning knob, the grub screw of which is accessible from the inside of the cabinet.

Lay the receiver on its back and remove the waveband and On/Off—Volume control knobs, by inserting a screw-driver through the two oval holes in the bottom of the

cabinet and loosening the grub screws.

The four bolts which hold the chassis to the cabinet will be found beneath the two pieces of wood on the bottom, each held by a wood screw.

Unsolder the two leads to the output transformer.

Take out the two small screws at the top of the pulley mounting plate.

Withdraw the chassis from the cabinet.

COIL CONNECTIONS.

Coil Tag Numbering.—Viewing the coil from the trimmer end, with the hinge of the moving plates on the left, tag number 1 is at the top and tags 2, 3 and 4 follow in a clockwise direction.

Switch Tag Numbering.—Switch tags are numbered in a clockwise direction when viewed from the front of the chassis, tag number 1 being on the right-hand side of the mounting screw nearest the bottom edge of the chassis.

S.W. Aerial Coil.

- Tag No. 1 to S1 tag No. 8.
- " " 2 to S1 tag No. 2 and TC1 fixed plates.
- " " 3 to L2 tag No. 4.
- " " 4 to L1 tag No. 3, VC1 moving plates and TC1 moving plates.

M.W. Aerial Coil.

- Tag No. 1 to S1 tag No. 9.
- " " 2 to S1 tag No. 3 and TC2 fixed plates.
- " " 3 to L5 tag No. 3.
- " " 4 to L6 tag No. 4, S1 tag No. 5 and TC2 moving plates.

L.W. Aerial Coil.

- Tag No. 1 to S1 tag No. 10, and C2.
- " " 2 to S1 tag No. 4, C6, and TC3 fixed plates.
- " " 3 to L3 tag No. 3, and chassis.
- " " 4 to C5, C6, L4 tag No. 4 and TC3 moving plates.

S.W. Oscillator Coil.

- Tag No. 1 to S2 tag No. 11.
- " " 2 to S2 tag No. 2 and TC4 fixed plates.
- " " 3 to S2 tag No. 8.
- " " 4 to TC4 moving plates and chassis.

M.W. Oscillator Coil.

- Tag No. 1 to S2 tag No. 11 and L13 tag No. 1.
- " " 2 to S2 tag No. 3 and TC5 fixed plates.
- " " 3 to S2 tag No. 9.
- " " 4 to C14, and TC5 moving plates.

L.W. Oscillator Coil.

- Tag No. 1 to L11 tag No. 1.
- " " 2 to S2 tag No. 4, C12 and TC6 fixed plates.
- " " 3 to S2 tag No. 10.
- " " 4 to C12, C13 and TC6 moving plates.

A.C.1 & D.A.C.1

CIRCUIT ALIGNMENT.

The use of a reputable signal generator, with a variable and modulated output, is essential for the accurate alignment of the R.F. and I.F. circuits.

A dummy aerial, consisting of a 400 ohm non-inductive resistor for the short waveband, and a fixed capacitor of 200mmfd. for Medium and Long wavebands, should be connected in series with the output of the signal generator.

A sensitive output meter should be used as a visual indicator.

To obtain the most accurate adjustment of the tuned circuits, use the lowest possible input to the receiver from the signal generator with the volume control of the receiver at maximum.

Check the position of the tuning pointer in relation to the tuning condenser; when the plates are fully meshed, the centre of the pointer should coincide with the two white marks at the top of the tuning scale, or looking at the back of the chassis, the uppermost mark on the calibrating scale.

INTERMEDIATE FREQUENCY CIRCUITS. 465 Kc/s.

Set the receiver to the Medium Waveband, with the tuning control at approximately 300 metres. Sub-harmonics of the I.F. should be avoided. Do not connect an aerial to the receiver.

Set the signal generator to 465 Kc/s., and connect to it V2 control grid (top cap). Adjust L16 and L15 in that order. Transfer the signal to V1 control grid (top cap), and adjust L8 and L7. With the signal still applied to V1 control grid, make a finer adjustment of L16, L15, L8, L7 and repeat in the reverse order for a final adjustment.

RADIO FREQUENCY CIRCUITS.

Short Waveband. 16 to 50 metres (18.75–6 Mc/s.)

- 1.—Set the signal generator to 25m. (12 Mc/s.) and connect via the dummy aerial to the sensitive aerial socket of the receiver.
- 2.—Tune the receiver to 25m.
- 3.—Adjust TC4 (oscillator) and TC1 (aerial) for maximum output.
- 4.—Check calibration on 50m. (6 Mc/s.)

Medium Waveband. 170–560m. (1.76 Mc/s.—535.7 Kc/s.)

- 1.—Set the signal generator to 200m. (1,500 Kc/s.) and connect via the dummy aerial to the sensitive aerial socket of the receiver.
- 2.—Tune the receiver to 200m.
- 3.—Adjust TC5 (oscillator) for maximum output.
- 4.—Re-tune signal generator and receiver to 300 m. (1,000 Kc/s.) and adjust TC2 (aerial) for maximum output.
- 5.—Check calibration on 500 m. (600 Kc/s.)

Long Waveband. 850–2,000 m. (352.9–150 Kc/s.)

- 1.—Set the signal generator to 1,000 m. (300 Kc/s.) and connect via the dummy aerial to the sensitive aerial socket of the receiver.
- 2.—Tune the receiver to 1000 m. (300 Kc/s.)
- 3.—Adjust TC6 (oscillator) and TC3 (aerial) for maximum output.
- 4.—Check calibration on 2000 m. (150 Kc/s.)

SERVICING NOTES.

Before proceeding to locate a fault in the receiver it is important to ensure all valves are up to standard and are making good contact in their holders.

Valve heaters should be checked for continuity, since failure in one valve will open circuit the whole heater chain.

Voltages on all valves and the mains transformer should be checked. The windings of the output transformer and speech coil should be checked for continuity, short circuit etc.

If these preliminary tests give satisfactory results, apply an A.F. signal to control grid of V3 to check stages V3 to V4. If there is little or no output, check all components from the anode resistor of V3 to grid of V4, including the cathode circuits of both valves.

To check the R.F. section of the receiver commence with the I.F. stage V2. Inject a 465 Kc/s. modulated signal, into the control grid of V2 (top cap) and if the receiver output is low check 2nd I.F. transformer and the decoupling components of V2, the A.V.C. components, detector and input circuits of V3.

The 1st I.F. transformer, can be checked by transferring the 465 Kc/s. signal to the hexode anode of V1. No greater output should be expected than from the previous test. If it is greatly reduced check the 1st I.F. transformer and

the input circuit to V2.

Apply an R.F. (modulated) signal, with the limits of the particular waveband, to the grid of V1 (top cap). If the signal can be tuned the oscillator circuits are correct, and the aerial circuits should be checked. If the circuit cannot be tuned inject into the oscillator grid of V1 a signal which is 465 Kc/s. higher than the frequency of a station known to be transmitting. If this station can be tuned at its correct position on the tuning scale the oscillator circuits would appear to be at fault.

A.V.C. LINE COMPONENTS : R2, R5, R15, C5, C15, C25.

DECOUPLING AND BIAS COMPONENTS :

- V1.—Screen and oscillator anode R1, C9. Bias R3, C8.
 V2.—Anode R9, C18. Screen R7, C16. Bias R8, C17.
 V3.—Bias R14, C26.
 V4.—Bias R19.

COMPONENTS AFFECTING CALIBRATION :

- Long Waveband** ... TC6, L13, L14, C12, C13.
Medium Waveband ... TC5, L11, L12, C14.
Short Waveband ... TC4, L9, L10.

MODIFICATION.

In later models of the AC.1 a plug and socket fitting on the mains voltage adjusting lead replaces the spade and terminal of the older models.

LIST OF PART NUMBERS.

The following part numbers are not shown elsewhere in this manual.

When ordering replacement or spare parts please quote :

- (a) Type and serial number of receiver.
- (b) Part number and description of item.
- (c) Quantity required.

Cabinet	EP15453
„ back A.C.1	EP15406
„ „ D.A.C.1	EP15445
„ bottom cut-out panel	EP15454

Cores, iron dust, medium and long	P2124
„ „ „ short	AP15378
„ „ „ I.F.	P8246
Grid cap, V3	S9389A
„ „ V2	S9389E
Indicator, waveband	AS15415
Knob, large	P12405
„ small	P12406
Mains ballast resistor assembly D.A.C.1 only	DS15441
Pointer	AS15419
Wire and anchor for drive	AS15433

ERRATUM : MODEL AC.1 and DAC.1

Resistors, page 3 should read VR1 2 megs. ganged to S3.
 Part No. CP15017.

ERRATUM : MODEL AC.1 and DAC.1

Specification, page 1. Weight should read : " Approximately 18 lbs."

Chisk, London