

BUSH RADIO

Service Information

Model VHF. 70 3 Waveband (inc. VHF) Table Radio



CONTENTS

GENERAL DESCRIPTION	Page 2
SPECIFICATION	2
DISMANTLING	2
Removal of chassis	2
Removal of VHF box	3
ALIGNMENT PROCEDURE	3
MAINTENANCE	7
Replacement of VHF tuning cord drive	7
Replacement of tuning capacitor cord drive	8
PARTS LISTS	8
Capacitors	8
Resistors	10
Coils and transformers	10
Miscellaneous	11
MODIFICATIONS	12
SPARES AND SERVICE	12

List of Illustrations

Fig. 1. Component layout in VHF box	Page 3
Fig. 2. Chassis viewed from below	4
Fig. 3. Chassis viewed from above	5
Fig. 4. Connection of meters	5
Fig. 5. Circuit Diagram	6
Fig. 6. Cord drive assembly (F.M.)	7
Fig. 7. Cord drive assembly (A.M.)	8

GENERAL DESCRIPTION

GENERAL

Seven-valve (including rectifier) superheterodyne receiver covering long, medium and VHF bands.

knobs with gold trim. Black and gold scale and Tygan speaker grille.

Width 12½ ins.

Height 9¾ ins.

CABINET

Maroon moulded plastic with champagne-silver surround for speaker and scale. White control

Depth 7 ins.

Weight 10½ lbs.

SPECIFICATION

WAVEBAND

Long waveband 1,050 to 1,935 metres (285 to 155 kc/s)

Medium waveband 187 to 560 metres (1,605 to 535 kc/s)

VHF band 87.5 to 100 Mc/s

VHF band—

An internal loaded dipole is fitted and connected to the receiver by means of an 80 ohm lead and two-pin plug. If necessary an external aerial may be connected in place of the internal dipole.

SCALE CALIBRATION

The long and medium wavebands are calibrated in metres and station names. The VHF band is calibrated in Mc/s with the Home, Light and Third programmes marked on the scale.

LOUDSPEAKER

6 in. × 4 in. elliptical. Flux 8,500 lines per sq. cm. There is no provision for using an external speaker.

INTERMEDIATE FREQUENCY

470 kc/s.

VALVES

Mullard types

V1—UCC85 grounded grid r.f. amplifier and mixer for f.m.

V2—UCH81 mixer for a.m. and i.f. amplifier for f.m.

V3—UF89 i.f. amplifier

V4—UF89 i.f. amplifier

V5—UABC80 detectors, a.g.c. diode and audio amplifier

V6—UL84 power output

V7—UY85 mains rectifier

VOLTAGE RANGE

200–250 volts a.c. (40–100 c/s) or d.c. There are three voltage-adjustment settings as follows:—

200–220 volt mains—set plug to 210 V socket.

220–240 volt mains—set plug to 230 V socket.

240–250 volt mains—set plug to 250 V socket.

POWER CONSUMPTION

45 watts.

CONTROLS

On tuning scale beneath speaker grille. Left, combined Volume and On/Off. Right, Tuning. Centre below scale, 3-position waveband-selector switch.

AERIAL

Long and medium wavebands—

An internal ferrite-rod aerial is fitted. There is no provision for using an external aerial.

AUDIO OUTPUT

2 watts.

DISMANTLING

REMOVAL OF CHASSIS

- 1 Remove the push-on control knobs.
- 2 Remove the ferrite rod by gently levering the rubber grommets free of the retaining brackets.
- 3 Remove the two chassis retaining bolts.
- 4 Remove the chassis. The leads to the output transformer are long enough to enable this to be done without unsoldering them.

REMOVAL OF VHF BOX

1 Unsolder the 5 connections to the box. They are:—

Pin 1 to S1d

Pin 2 to HFC2

Pin 3 to V2, pin 5

Pin 4 to S1b

Pin 5 to chassis

2 Set the tuning capacitor to minimum and unhook the spring from the drive drum.

3 Remove the cord drive from the drive drum.

4 Withdraw the screw and washer (A—Fig. 3) from the pivoted adjuster.

5 Unscrew and remove the drive drum.

6 Remove the cord loop from the brass boss.

7 Remove the three screws holding the box to the retaining bracket (Fig. 3) and remove the bolt (A—Fig. 2) from beneath the chassis.

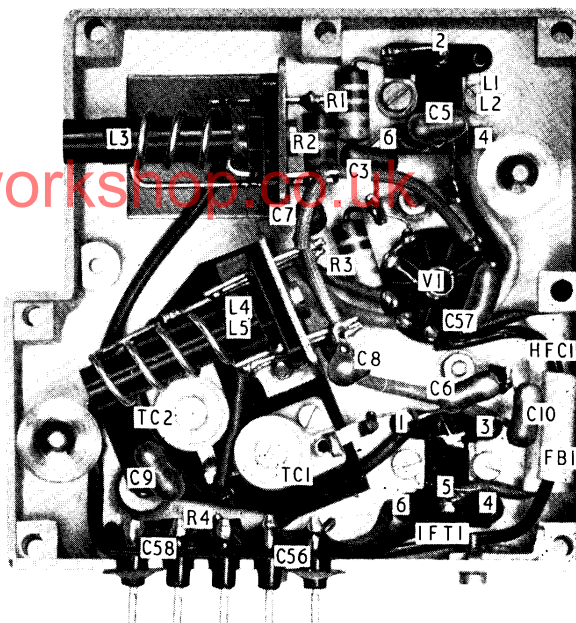

Fig. 1 Component layout in VHF box.

ALIGNMENT PROCEDURE

WARNING

It is best always to connect the chassis to the mains via an isolating transformer or at least to connect it to the neutral side of the mains. No earth connection either direct or through earthed equipment should be made to the receiver.

PRELIMINARY NOTES

1 Remove the receiver from the cabinet.

2 Switch on the receiver and generator about 15 minutes before starting the alignment.

Equipment required

1 A signal generator covering 200 kc/s to 1,500 kc/s, 10.7 Mc/s and 87.5 Mc/s to 100 Mc/s.

2 An output meter to match to 2.5–3 ohms impedance.

3 A non-metallic trimming tool.

4 An Avometer Model 8 or both a d.c. valve voltmeter and a micro-ammeter (50 μ A f.s.d.).

5 Two 47 k, $\frac{1}{4}$ watt resistors and a 1 k, $\frac{1}{4}$ watt resistor.

A.M. STAGES

I.F. Alignment—

Notes: The primary of all I.F.T.'s is at the bottom of the can.

Switch the receiver to the M.W. band. Set the auxiliary pointer (see Fig. 3) to 300 metres. Turn the Volume control to maximum.

1 Inject a signal of 470 kc/s, modulated 30 per cent at 400 c/s to pin 2, V4 and adjust the cores of IFT6 to produce maximum audio output.

2 Transfer the signal to pin 2, V2 and adjust the cores of IFT4 and IFT2 for maximum output.

R.F. Alignment—

Notes: For alignment of the long and medium wavebands the signal should be applied to the junction of C12 and VCI (the tag on the gang is a convenient point) via a 0.1 μ F capacitor. Turn the Volume control to maximum.

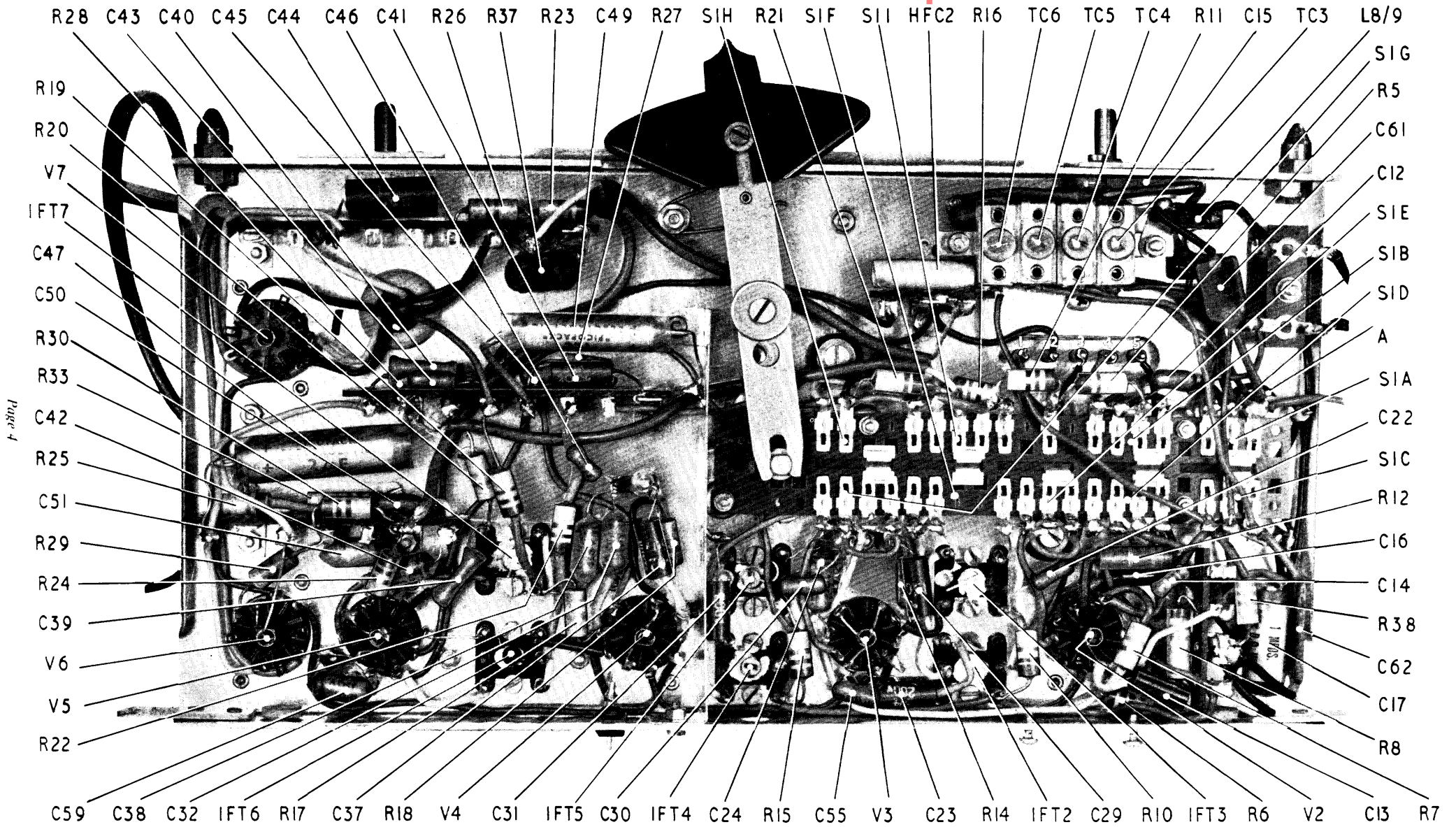

Fig. 2 Chassis viewed from below.

Page 4

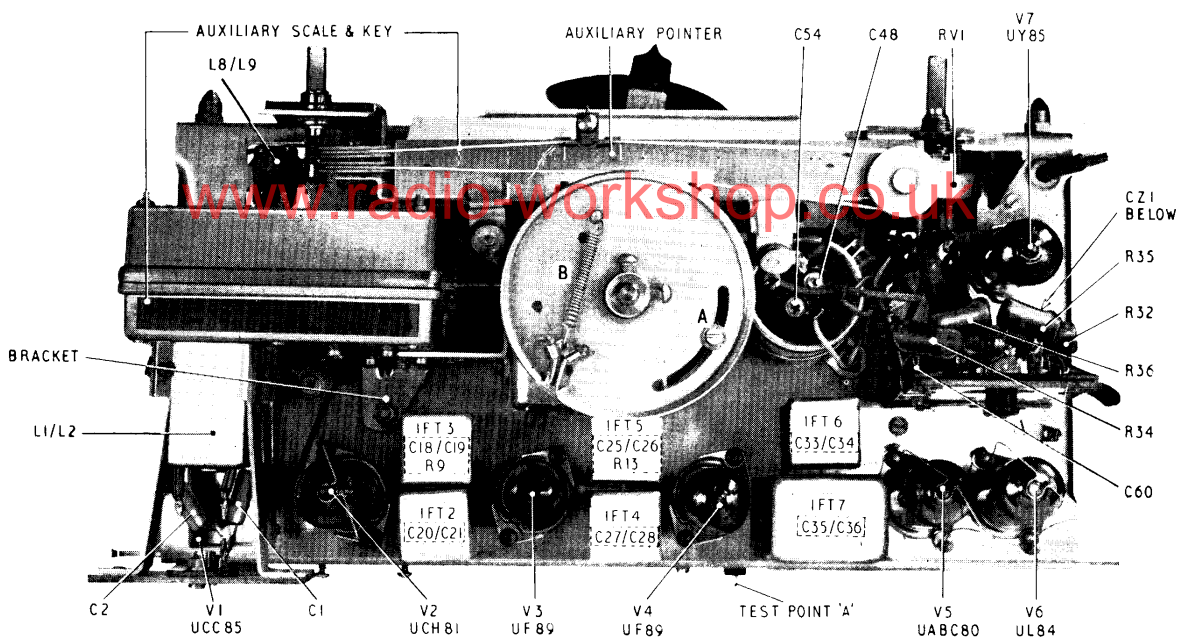

Fig. 3 Chassis viewed from above.

Operation	Waveband	Signal Generator Frequency	Receiver Calibration	Adjust for Maximum
1	M.W.	600 kc/s	500 metres	L8/L9 (osc.)
2	M.W.	1,500 kc/s	200 metres	TC6 (osc.)
3	Repeat operations 1 and 2 and check calibration.			
4	L.W.	214 kc/s	1,400 metres	TC5 (osc.)

F.M. STAGES

I.F. Alignment—

Notes: IFT3 and IFT5 have the primary at the bottom and IFT7 has the primary at the top.

Before commencing alignment check the position of the iron-dust cores in the i.f. transformers and adjust, if necessary, as follows:—IFT3 and IFT5; primary and secondary cores to be $\frac{1}{8}$ in. inside the coil former; IFT7 primary core to be $\frac{3}{8}$ in. inside the former, secondary core to be $\frac{3}{8}$ in. inside the coil former.

The correct peak associated with all the cores except that of the discriminator primary is the first one reached entering the winding from either the base or the top of the former.

During alignment the signal input must always be maintained at a level just sufficient to produce an output of 4 V d.c. each time an adjustment is made to any core.

The two 47 k resistors should be connected across the discriminator stabilizing capacitor C49 as shown in Fig. 4.

The signal should be applied via a 0.1 μ F capacitor.

1 Inject an i.f. signal of 10.7 Mc/s to pin 2, V2.

2 Adjust the primary core of IFT7 to produce maximum d.c. output.

3 Adjust the secondary core of IFT7 to produce zero on the d.c. balance meter.

4 Connect the 1k damping resistor across the secondary of IFT5 and adjust the primary for maximum d.c. output.

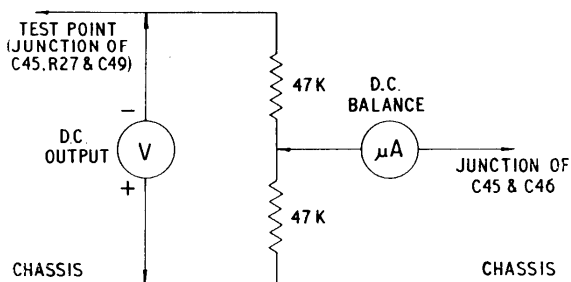
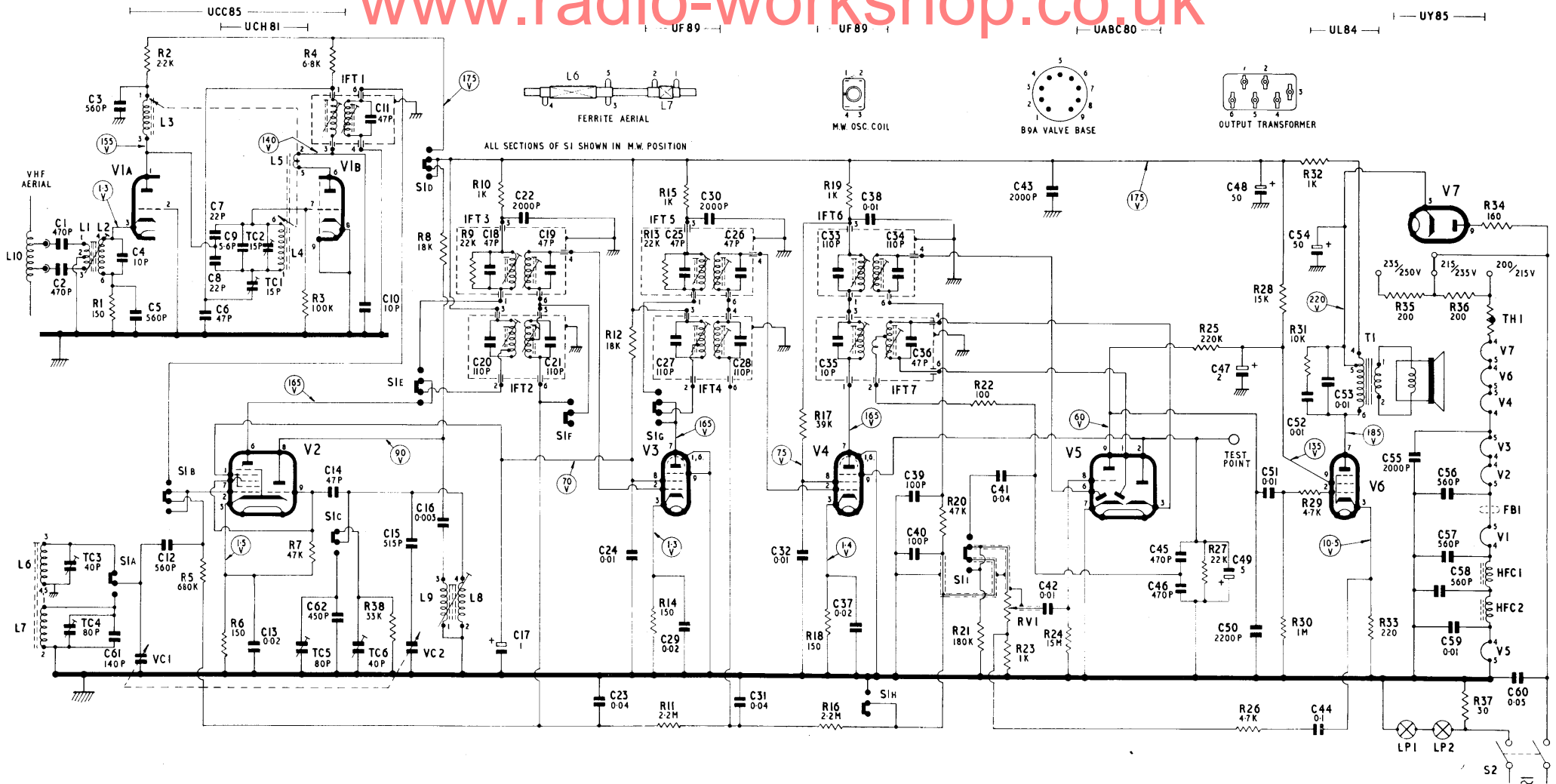

Fig. 4 Connection of meters.



NOTE:- All voltages measured with Avo Model 7, chassis negative on 1,000-volt or 10-volt ranges.

Readings marked M.W. will be obtained with wave-band switch in the M.W. position.

All other readings taken with switch in the VHF position.

Fig. 5 Circuit Diagram

Alignment Procedure continued

5 Transfer the damping to the primary and adjust the secondary core to produce maximum d.c. output.

6 Transfer the damping to the secondary of IFT3 and adjust the primary core to produce maximum d.c. output.

7 Transfer the damping to the primary and adjust the secondary core to produce maximum d.c. output. Remove the damping.

8 Readjust the primary core of IFT7 for maximum d.c. output.

9 Readjust the secondary core of IFT7 for zero on the d.c. balance meter.

10 Transfer the signal input to the VHF aerial sockets and adjust the secondary core of IFT1 for maximum d.c. output.

R.F. Alignment—

Inject an 87.5 Mc/s signal at the aerial sockets and set the auxiliary pointer to the corresponding calibration point.

1 Slacken the locking screw "A" (see Fig. 3) on the pivoted adjuster and rotate the arm, thus adjusting the cores of L3 (r.f.) and L4/L5 (oscillator) for maximum d.c. output. Then tighten the locking screw.

2 Set the generator and the pointer to 94 Mc/s and adjust the core of L1/L2 for maximum d.c. output.

3 Check calibration.

Note: TC1 (the oscillator-bridge balancing trimmer) has been pre-set at the factory to produce minimum oscillator radiation and TC2 has been pre-set in conjunction with the mechanical adjustment of L3 and L4/L5 for optimum calibration. It is extremely unlikely that these settings will subsequently vary and therefore no data are given for them.

Replacement of V1 may cause slight changes in oscillator calibration. Resetting the cores as in 1 above should correct this.

MAINTENANCE

REPLACEMENT OF VHF TUNING CORD DRIVE

If a breakage occurs in either the cord or the cores the complete assembly should be replaced. A recommended procedure for replacement is as follows:—

Remove the chassis from the cabinet. Unscrew and remove the front cover of the VHF box. Set the tuning capacitor to minimum. Unhook the spring from the drive drum and remove the A.M. cord drive. Remove the grub screws holding the drive drum and remove the screw and washer (A—Fig. 3) then remove the drive drum.

Replace the cord as shown in the diagram.

After reassembly check that the auxiliary pointer coincides with the datum indent when the tuning capacitor is at maximum capacity and reset the pivoted adjuster as described in the alignment procedure.

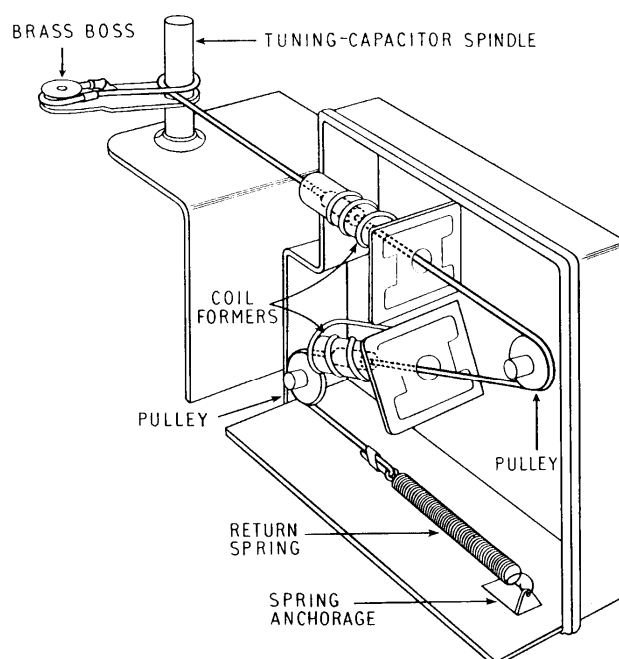

Fig. 6 Cord drive assembly (F.M.).

REPLACEMENT OF TUNING CAPACITOR CORD DRIVE

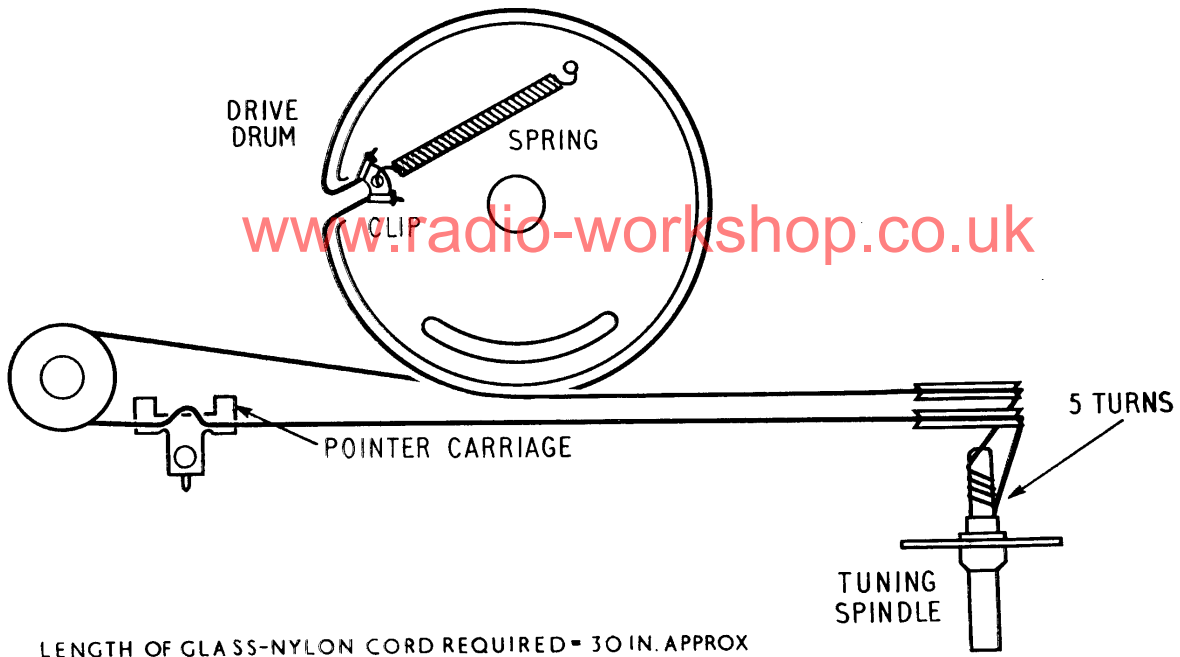

Fig. 7 Cord drive assembly (A.M.).

PARTS LISTS

Ordering to these part numbers will give the right type and rating of component. When fitting replacements from stock always use the same type as that of the component being replaced.

CAPACITORS

Reference	Value		Tolerance (±%)	Rating (volts)	Part Number
	μF	pF			
C1	—	470	25	1750	AP21458
C2	—	470	25	1750	AP21458
C3	—	560	20	750	AP23405
C4	—	10	5	350	AP24847
C5	—	560	20	750	AP23405
C6	—	47	5	750	AP24630
C7	—	22	2	750	AP24626
C8	—	22	2	750	AP24626
C9	—	5.6	±5 pF	750	AP24628
C10	—	10	5	750	AP24629
C11	—	47	5	350	AP24848
C12	—	560	20	750	AP23405
C13	0.02	—	20	150	AP22251
C14	—	47	20	750	AP17338
C15	—	515	1	350	AP17175
C16	0.003	—	20	400	AP22249
C17	1	—	—	200	AP61751
C18	—	47	5	350	AP24848
C19	—	47	5	350	AP24848
C20	—	110	2	350	AP25808
C21	—	110	2	350	AP25808
C22	—	2000	±50—25	750	AP23407

Reference	Value		Tolerance (±%)	Rating (volts)	Part Number
	μF	pF			
C23	0.04	—	20	200	AP24028
C24	0.01	—	25	350	AP24117
C25	—	47	5	350	AP24848
C26	—	47	5	350	AP24848
C27	—	110	2	350	AP25808
C28	—	110	2	350	AP25808
C29	0.02	—	20	150	AP22251
C30	—	2000	±50—25	750	AP23407
C31	0.04	—	20	200	AP24028
C32	0.01	—	25	350	AP24117
C33	—	110	2	350	AP25808
C34	—	110	2	350	AP25808
C35	—	10	5	350	AP24847
C36	—	47	5	350	AP24848
C37	0.02	—	20	150	AP22251
C38	0.01	—	25	350	AP24117
C39	—	100	20	750	AP17336
C40	—	100	20	750	AP17336
C41	0.04	—	20	200	AP24028
C42	0.01	—	25	350	AP24117
C43	—	2000	±50 25	750	AP23407
C44	0.1	—	20	150	AP21245
C45	—	470	20	500	AP24631
C46	—	470	20	500	AP24631
C47	2	—	±50—20	350	AP24841
C48	50	—	±50—20	275	AP24627
C49	5	—	±50—20	50	AP61921
C50	—	2200	20	750	AP24717
C51	0.01	—	25	350	AP24117
C52	0.01	—	25	500	P3769
C53	0.01	—	25	500	P3769
C54	50	—	±50—20	275	In can with C48
C55	—	2000	±50—25	750	AP23407
C56	—	560	20	750	AP23405
C57	—	560	20	750	AP23405
C58	—	560	20	750	AP23405
C59	0.01	—	25	350	AP24117
C60	0.05	—	20	500	AP15077
C61	—	140	1	350	AP20607
C62	—	450	1	350	AP25616
TC1	—	3-15	—	—	AP24623
TC2	—	3-15	—	—	AP24623
TC3	—	3-40	—	—	} AP61376
TC4	—	10-80	—	—	
TC5	—	10-80	—	—	
TC6	—	3-40	—	—	
VC1	—	528	Ganged	—	BP23657
VC2	—	528			

RESISTORS

Reference	Value (ohms)	Tolerance (± %)	Rating (watts)	Part Number
R1	150	10	$\frac{1}{4}$	P6155
R2	2.2k	10	$\frac{1}{4}$	P6449
R3	100k	10	$\frac{1}{4}$	P6869
R4	6.8k	10	$\frac{1}{2}$	P6574
R5	680k	20	$\frac{1}{4}$	P7073
R6	150	10	$\frac{1}{4}$	P6155
R7	47k	20	$\frac{1}{4}$	P6779
R8	18k	10	$\frac{1}{2}$	P6676
R9	22k	10	$\frac{1}{4}$	P6701
R10	1k	20	$\frac{1}{4}$	P6359
R11	2.2M	20	$\frac{1}{4}$	P7199
R12	18k	10	$\frac{1}{2}$	P6676
R13	22k	10	$\frac{1}{4}$	P6701
R14	150	10	$\frac{1}{4}$	P6155
R15	1k	20	$\frac{1}{4}$	P6359
R16	2.2M	10	$\frac{1}{4}$	P7205
R17	39k	10	$\frac{1}{4}$	P6761
R18	150	10	$\frac{1}{4}$	P6155
R19	1k	20	$\frac{1}{4}$	P6359
R20	47k	20	$\frac{1}{4}$	P6779
R21	180k	20	$\frac{1}{4}$	P14227
R22	100	20	$\frac{1}{4}$	P6107
R23	1k	10	$\frac{1}{4}$	P6365
R24	15M	33 $\frac{1}{3}$	$\frac{1}{4}$	P14548
R25	220k	10	$\frac{1}{4}$	P6953
R26	4.7k	10	$\frac{1}{4}$	P6533
R27	22k	10	$\frac{1}{4}$	P6701
R28	15k	10	$\frac{1}{2}$	P6658
R29	4.7k	20	$\frac{1}{4}$	P6527
R30	1M	20	$\frac{1}{4}$	P7115
R31	10k	10	$\frac{1}{4}$	P6617
R32	1k	5	8	AP19726
R33	220	10	$\frac{1}{2}$	P6196
R34	160	5	6	AP61152
R35	200	5	4	AP24624
R36	200	5	4	AP24624
R37	30	5	4	AP23458
R38	33k	10	$\frac{1}{4}$	P6743
RV1	500k Semi Log	—	—	BP24625

COILS AND TRANSFORMERS

Reference	Description	D.C. Resistance (ohms)	Part Number
L1	aerial coil (f.m.)	less than 0.5	CS24884
L2		less than 0.5	
L3	anode coil	less than 0.5	BS24885
L4	oscillator coil (f.m.)	less than 0.5	BS24883
L5		less than 0.5	
L6	ferrite rod aerial (m.w.)	0.5	DS61722
L7		(l.w.) 14	
L8	oscillator coil (a.m.)	5	BS61829
L9		1.5	
L10	aerial loading coil (f.m.)	less than 0.5	AS24894
HFC1	heater choke	less than 0.5	AS24886
HFC2	heater choke	less than 0.5	AS24886
IFT1	1st i.f. transformer (f.m.)		
	—primary	less than 0.5	BS24879
	—secondary	less than 0.5	

Coils and Transformers continued

Reference	Description	D.C. Resistance (ohms)	Part Number
IFT2	1st i.f. transformer (a.m.)		CS24880
	—primary	14	
	—secondary	14	
IFT3	2nd i.f. transformer (f.m.)		BS24878
	—primary	less than 0.5	
	—secondary	less than 0.5	
IFT4	2nd i.f. transformer (a.m.)		CS24881
	—primary	14	
	—secondary	14	
IFT5	3rd i.f. transformer (f.m.)		BS24878
	—primary	less than 0.5	
	—secondary	less than 0.5	
IFT6	3rd i.f. transformer (a.m.)		BS24304
	—primary	14	
	—secondary	14	
IFT7	discriminator transformer		CS24882
	—primary	less than 0.5	
	—secondary	less than 0.5	
	—tertiary	less than 0.5	
T1	output transformer		AS24916 (AS24915 with C's and R's)
	—primary	600	
	—buck winding	5.5	
	—secondary	0.46	

MISCELLANEOUS

Description	Part Number
cabinet	DP61667
cabinet back	DS61688
cabinet back with aerial	DS61687
control knob (2)	AS60482
cord clip	P1940
cord drive assembly	AS24899
cord drive pulley (white)	P12416
cord spring	P1941
drive drum	AP24685
ferroxcube core	AP22966
iron dust core (L3/4/5)	AP24617
iron dust core (HFC1/2)	AP24621
iron dust core (all other coils)	AP17109
knob assembly	AP60480
knob clip	AP16423
loudspeaker, p.m. oval	BP26490
moulded escutcheon	AP61690
pilot lamp 3.5 V, 0.15 A (2)	AP16631
pointer assembly	AS24898
pointer	AP24743
pointer carriage	AP23662
slider switch	BP61660
thermistor CZ1	AP16020
tuning scale	EP61678
v.h.f. tuning core assembly	CS24888
v.h.f. tuning cord spring	AP24740
v.h.f. tuning cord pulley (black)	AP24684
v.h.f. box	ES24892
valve retainer	AP25780
wavechange knob	AP24737
wavechange knob spring	AP61672