

"TRADER" SERVICE SHEET
1718

BUSH VHF81

Thre
T

INCORPORATING a conventionally wired vertical chassis, Bush VHF81 is a three-waveband a.m./f.m. table radio receiver designed for mains operation. It employs six valves plus rectifier and is housed in wooden veneered cabinet.

Internal aerials are provided for a.m. and f.m. reception, and provision is made for the connection of an external f.m. aerial. A low impedance output from a separate winding on the output transformer is available for feeding a tape recorder.

Waveband ranges are 187-560m (m.w.), 1,050-1,935m (l.w.) and 87.5-100Mc/s (f.m.) with waveband selection by press-button switching. Audio power output is 2W and operating power consumption is 45W.

Release date and original price: July 1964 £22 12s 5d. Purchase tax extra.

VALVE ANALYSIS

Valve voltages given in the table in col. 1 were derived from information supplied by the manufacturers. They were measured on an Avometer model 8 and are positive with respect to chassis.

Valve Table

Valve	Anode (V)	Screen (V)	Cathode (V)
V1a UCC85	152†	—	0.9
V1b UCC85	152†	—	—
V2 UF89	75	68	—
V3a UCH81	80	72	—
V3b UCH81	92	—	0.1
V4 UF89	145	70	0.1
V5d UABC80	158	70	0.1
V6 UL84	142	81	—
V7 UY85	158	88	—
V5d UABC80	55	—	—
V6 UL84	58	—	—
V6 UL84	188	104	6.9
V7 UY85	193	112	7.4
V7 UY85	—	—	206.0
V7 UY85	—	—	213.0

*Receiver switched to f.m.
†Receiver switched to a.m. (m.w.)
‡Measured at the junction R3, R5 and S3g.

meter; a 0.1μF isolating capacitor; a matched pair of 47kΩ resistors; a damping unit comprising a 1kΩ resistor, and two trimming tools, a non-metallic type 10in long for adjusting the f.m. i.f. cores and a special type for the a.m. i.f. cores.

A.M. CIRCUITS

In IFT3 and IFT6 the primary core is adjusted from the base and the secondary core from the top of the can.

- 1.—Switch receiver to m.w. and set the cursor to an unused frequency around 300m. Turn the volume control fully clockwise. Connect the audio output meter in place of the loudspeaker. During alignment adjust the input signal level to maintain an output of 50mW.
- 2.—Connect the signal generator via the 0.1μF isolating capacitor between V4 pin 2 and chassis. Feed in a 470kc/s 30 per cent modulated signal and adjust the cores of IFT6 for maximum output.
- 3.—Transfer the signal generator to V3 pin 2 and adjust the cores of IFT3 for maximum output.
- 4.—Transfer the signal generator to V2 pin 2 and adjust the core of L8 for minimum output.
- 5.—Connect the signal generator to the r.f. coupling loop and loosely couple (Continued overleaf, col. 1)

CIRCUIT ALIGNMENT

The receiver and signal generator should be switched on for about 15 minutes before alignment. The receiver chassis should be removed from its cabinet for alignment; as described under "Dismantling."

Equipment Required.—An a.m. signal generator covering the a.m. and f.m. wavebands, modulated 30 per cent at 400c/s, and capable of being switched to c.w.; a 0.2W audio output meter to match an impedance of 3Ω; a length of insulated wire to be formed into an r.f. coupling loop; an Avometer model 8 for use as a d.c. output meter and balance

C	1,2,3	6,5	4	7,8,9,TC2	TC1	10 12	11	14,13,TC4,TC3	VC1	15	18,16	19	60,17,21	20,59,22	25 58	29,VC2,51,TC5,57
R		1	2 3		4	5				6 8	7			10 9 11	13 14	

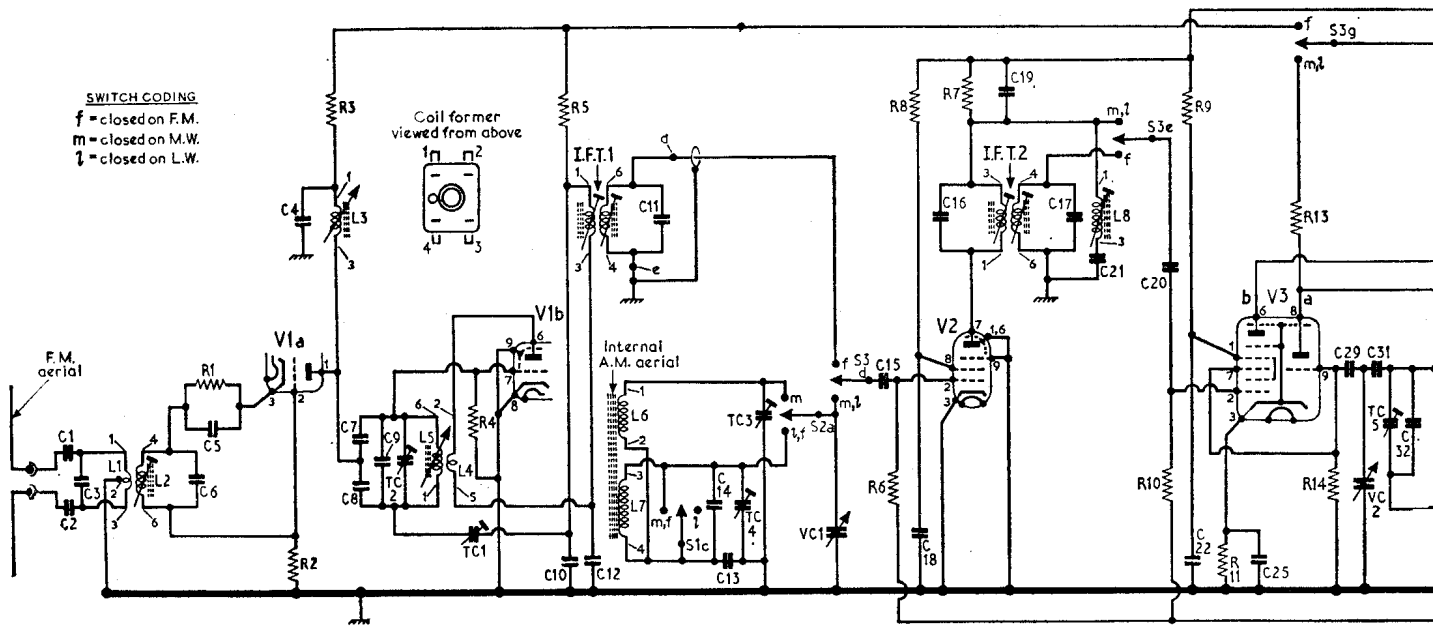

Circuit diagram of Bush VHF81 a.m./f.m. radio receiver. V2 operates as an i.f. amplifier on f.m. and as an untuned r.f. stage on a.m. L8, C21 constitute an i.f. trap circuit in V3b grid input on a.m.

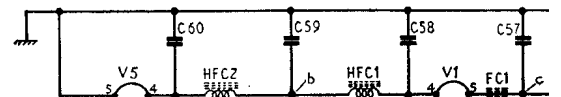

Free-Waveband A.M./F.M.
Table Radio Receiver

Resistors			R11	10Ω	B2
R1	82Ω	H6	R12	1kΩ	B2
R2	27Ω	H6	R13	15kΩ	E3
R3	2.2kΩ	H6	R14	47kΩ	B2
R4	100kΩ	H6	R15	2.2kΩ	B1
R5	6.8kΩ	H5	R16	22kΩ	B2
R6	680kΩ	B2	R17	1kΩ	A2
R7	2.2kΩ	B2	R18	100Ω	A2
R8	10kΩ	B2	R19	22kΩ	B2
R9	10kΩ	B2	R20	2.2MΩ	B2
R10	680kΩ	B2	R21	330kΩ	A2
			R22	100kΩ	A2

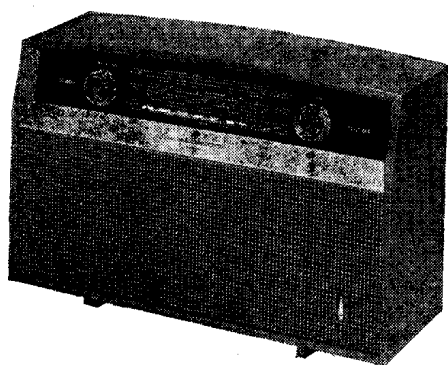

Appearance of the Bush VHF81

Capacitors			C27	47pF	F4
C1	470pF	E4	C28	150pF	F4
C2	470pF	D4	C29	100pF	B2
C3	15pF	H6	C30	0.01μF	B2
C4	560pF	H6	C31	515pF	B2
C5	560pF	H6	C32	450pF	B2
C6	10pF	D4	C33	1,000pF	B2
C7	22pF	H6	C34	4,700pF	B2
C8	22pF	H6	C35	150pF	G4
C9	5.6pF	H5	C36	10pF	G4
C10	47pF	H6	C37	0.04μF	B2
C11	47pF	C2	C38	4,700pF	A2
C12	10pF	H6	C39	560pF	B2
C13	7,500pF	E3	C40	2,200pF	B2
C14	120pF	F3	C41	150pF	G4
C15	270pF	B2	C42	47pF	G4
C16	47pF	E4	C43	100pF	A2
C17	47pF	E4	C44	0.01μF	G4
C18	4,700pF	B2	C45	270pF	A2
C19	33pF	B2	C46	5μF	G4
C20	270pF	B2	C47	3,000pF	G3
C21	47pF	C2	C48	20μF	F3
C22	4,700pF	B2	C49	0.01μF	A2
C23	47pF	F4	C50	0.01μF	A2
C24	150pF	E4	C51	3,000pF	A2
C25	4,700pF	B2	C52	40μF	F3
C26	4,700pF	B2	C53	0.04μF	F3
			C54	40μF	F3
			C55	2,200pF	B2
			C56	2,200pF	B2
			C57	560pF	H6
			C58	560pF	H6
			C59	560pF	H5
			C60	2,200pF	A2
			C61	0.02μF	G3
			C62	100pF	A2
			TC1	15pF	H6
			TC2	15pF	H6
			TC3	30pF	F3
			TC4	30pF	F3
			TC5	40pF	E4
			TC6	40pF	E4
			VC1	528pF	E3
			VC2	528pF	E4

Coils*			L1	—	D4
L2	—	—	L3	—	D4
L4	—	—	L5	—	H6
L6	—	—	L7	—	H6
L8	18.0	C2	L9	1.5	E4
L10	4.8	E4	L11	—	E4

Transformers*			IFT1	—	C2
IFT2	—	E4	IFT3	{ pri. 14.0 sec. 14.0 }	F4
IFT4	—	F4	IFT5	—	G4
IFT6	{ pri. 14.0 sec. 14.0 }	G4	T1	{ pri. 600.0 sec. — }	F4

Miscellaneous			FC1	—	H6
LP1	6.3V 115mA	E3	LP2	M.E.S.	F3
S1-S3	—	B2	S4	—	G3
TH1	VA1010	F3	TH2	VA1010	E3
HFC1	—	H6	HFC2	—	A2

* Approximate d.c. resistance in ohms.

57,32,TC6,56,33	23,24	55,26	30, 27,28, 34	38, 35,36,37	39,41,42,43,40	62	46	54	44	47	45,52,49	48	50, 61,51	53	C
15	12	16	17	TH2,36,18	21,19	22	23,37,TH1,34,20	RV1	25	26,35	28,31	30,33,29,32	27,24	R	

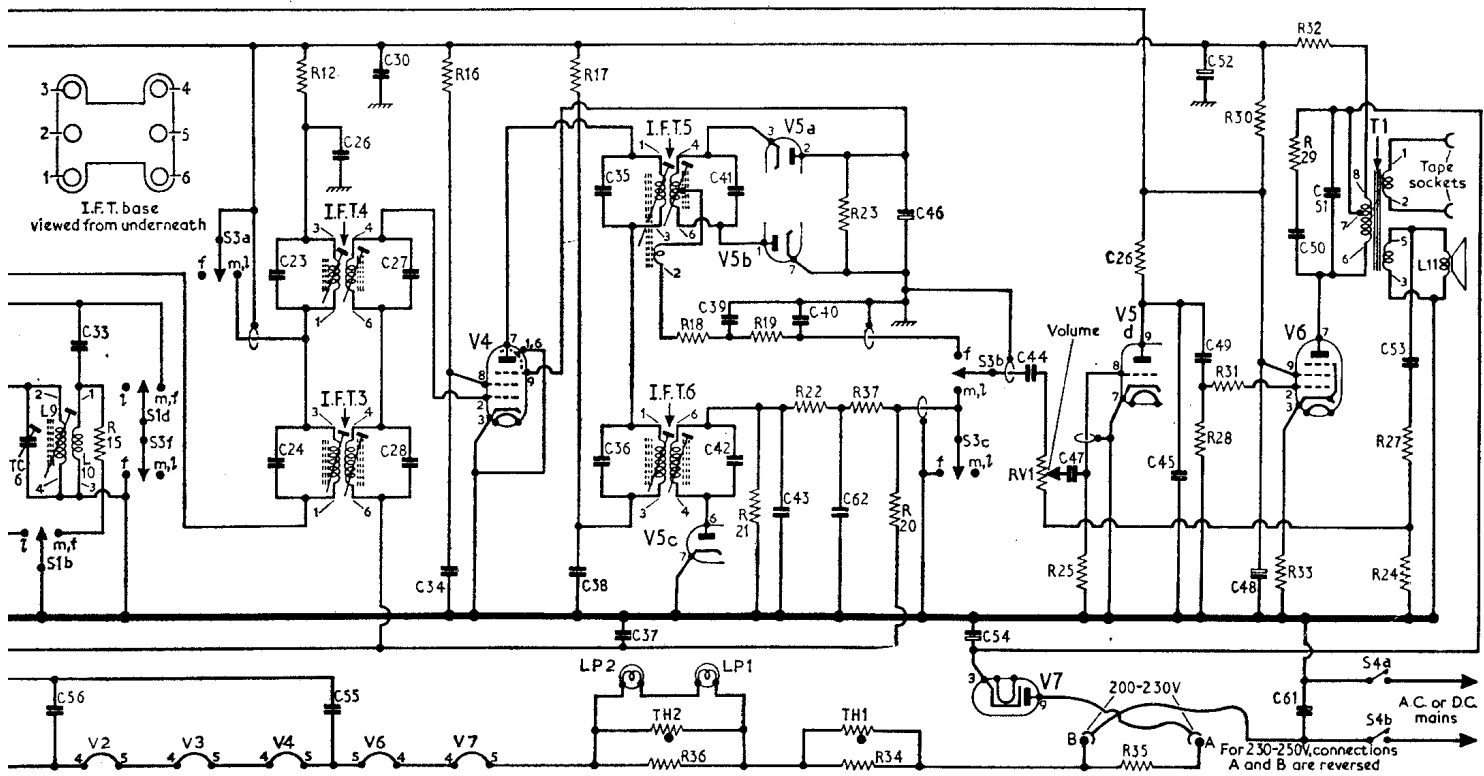

www.radio-workshop.co.uk

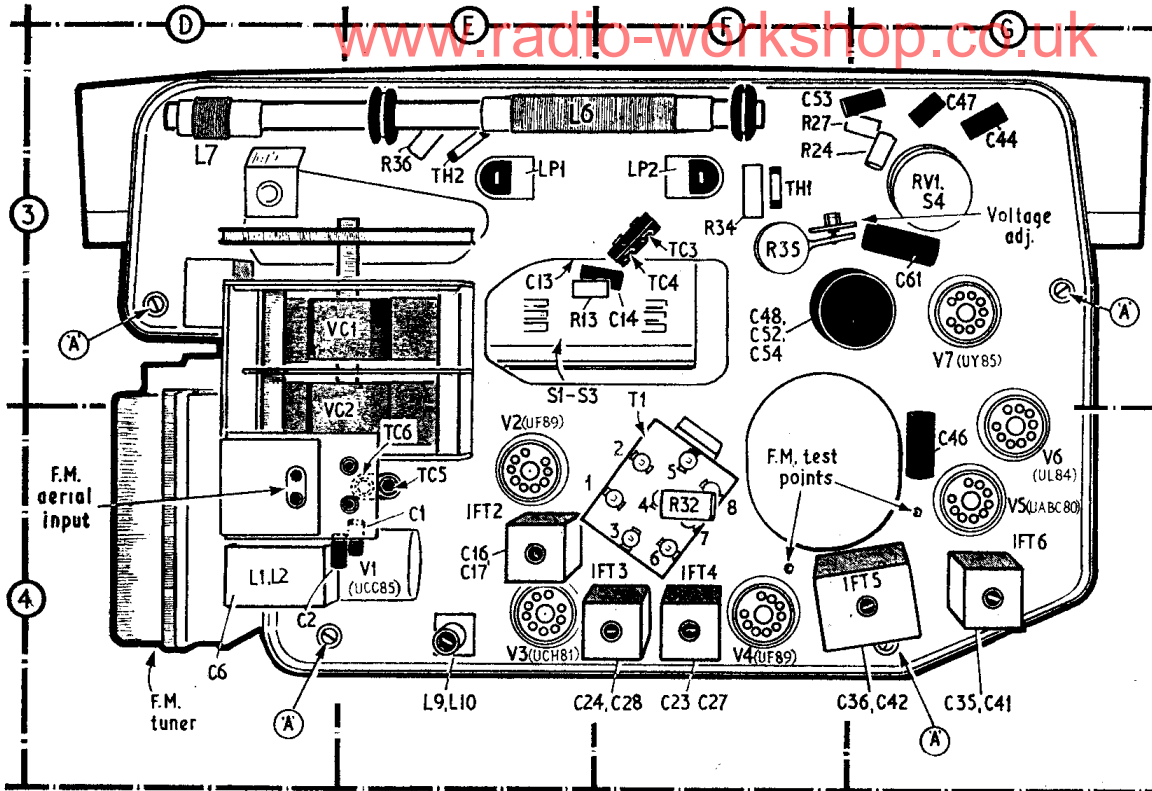

Left: The metal chassis as seen from the rear showing valve positions and alignment adjustment locations

Right: Front view of the chassis giving component locations. Tags a-e on the f.m. tuner (location reference C2) identify the tuner connections with the main chassis

Continued—

- the loop to the receiver by placing it about three feet from the receiver with its plane at right-angles to the ferrite rod aerial. Check that with the tuning gang at maximum capacitance, the cursor is in line with the datum marks at the l.f. end of the scale.
- 6.—Switch receiver to m.w. and set the cursor at 500m. Feed in a 600kc/s signal and adjust L9 for maximum output.
- 7.—Set the cursor to 200m, feed in a 1,500kc/s signal and adjust TC6 for maximum output.
- 8.—Repeat operations 6 and 7 and check calibration.
- 9.—Set the cursor to 200m, feed in a 1,500kc/s signal and adjust TC3 for maximum output.
- 10.—Switch receiver to l.w. and set the cursor to 1,400m. Feed in a 214kc/s signal and adjust TC5 and TC4 for maximum output. Seal trimmers.

F.M. CIRCUITS

In IFT1, IFT2 and IFT4 the primary core is adjusted from the base, and the secondary core from the top of the can. In IFT5 (discriminator) the primary core is adjusted from the top, and the second-

ary core from the base of the can. With the exception of IFT5 primary the correct peak is that which occurs with the core in the outer position. The primary of IFT5 should be peaked with the core in the inner position.

- 1.—Switch receiver to f.m. and set IFT2 and IFT4 primary and secondary cores to be $\frac{1}{2}$ in inside the coil former. Set the primary core of IFT5 to be $\frac{1}{2}$ in inside the former and the secondary core to $\frac{1}{2}$ in inside the former. Turn the volume control fully anti-clockwise.
- 2.—Connect the Avometer switched to a suitable d.c. voltage range between the negative end of C46 and chassis (positive terminal to chassis). Connect the signal generator via the 0.1 μ F capacitor to V3 pin 2.
- 3.—Feed in a 10.7Mc/s signal and adjust the input level to produce an output of 4V on the d.c. meter. (Maintain this output level throughout alignment by reducing the signal input as necessary.)
- 4.—Adjust IFT5 primary for maximum reading on the d.c. meter.

- 5.—Connect the two matched 47k Ω resistors in series across C46, and connect the Avometer (switched to a suitable μ A range) between their junction and the junction R18, R19, C39. Adjust IFT5 secondary for zero reading on the meter.
- 6.—Reconnect the Avometer as in operation 2. Connect the 1k Ω damping resistor across IFT4 secondary and adjust the primary core for maximum meter reading. Then transfer the damping resistor to IFT4 primary and adjust the secondary core for maximum meter reading.
- 7.—Transfer the signal generator to V2 pin 2. Connect the damping resistor across IFT2 secondary and adjust the primary core for maximum meter reading. Then transfer the damping resistor to IFT2 primary and adjust the secondary for maximum meter reading. Remove the 1k Ω damping resistor.

The drive cord assembly (below left) seen from the front, and (below) front and rear views of the waveband switch assembly

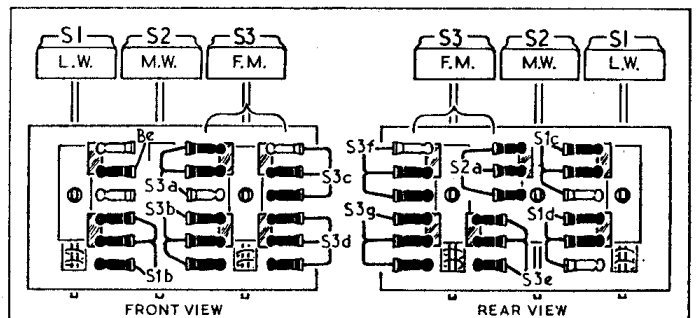
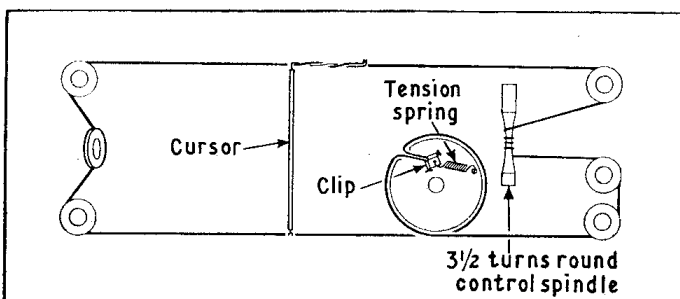

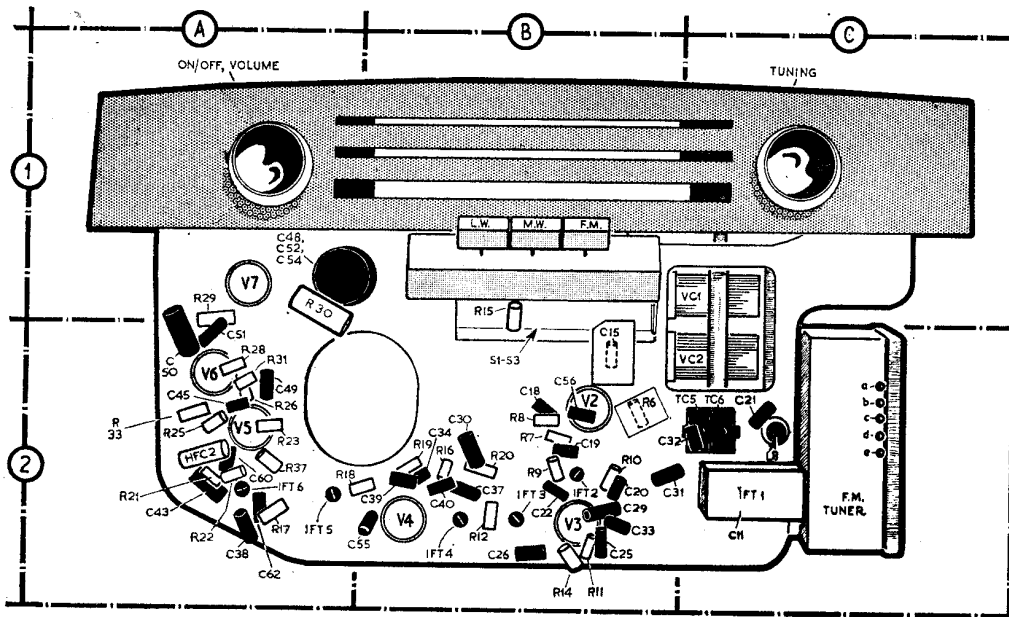

GENERAL NOTES

Main Drive Cord Replacement.—To fit a replacement main tuning drive cord, remove the chassis from the cabinet as described under "Dismantling." Loosen two 6BA screws securing the scale lamps at each side of the chassis. Slacken the 4BA screws securing the control knobs but do not attempt to withdraw the knobs through the holes in the tuning scale. Lift the tuning scale with the control knobs clear of the chassis. Remove the old cord and route the replacement as shown in the sketch in col. 1.

F.M. Tuning Cord Replacement.—If a breakage occurs in either the tuning cord or the cores, the complete assembly should be replaced.

Remove the chassis from the cabinet as described under "Dismantling." Remove the die-cast cover from the f.m. unit. Set the a.m. tuning capacitor to minimum and remove the locking screw and washer of the pivoted adjuster, located in the curved slot of the tuning drum. Unhook and remove the cord assembly from the return spring, and from the pivoted adjuster and fit the new assembly as shown in the f.m. tuner unit illustration.

When reassembling, check that with the tuning gang at maximum capacitance, the cursor is in line with the datum marks at the right-hand end of the scale. Set the pivoted adjuster as described in operation 10 of "Circuit Alignment" (F.M. Circuits).

Switches.—S1-S3 are the waveband switches comprising a press-button unit shown on the chassis diagram in location reference B1, with details drawn separately in col. 3. On the circuit diagram the switch contacts are lettered in accordance with a coding key indicating their closed position. S4 is a double-pole mains on/off switch which is ganged with the volume control.

8.—Readjust the primary of IFT5 for maximum meter reading, then connect the meter as in operation 5 and readjust the secondary of IFT5 for zero meter reading.

9.—Reconnect the Avometer as in operation 2. Transfer the signal generator to the f.m. aerial sockets. Connect the 1kΩ damping resistor across IFT2 primary and adjust IFT1 secondary for maximum meter reading. Remove the damping resistor.

10.—Tune receiver to 87.5Mc/s and feed in an 87.5Mc/s unmodulated signal. Slacken the f.m. tuning pivoted adjuster locking screw (see sketch) and rotate the adjusting arm (thus moving the cores of L3 and L5), for maximum meter reading.

11.—Tune receiver to 94Mc/s. Feed in a 94Mc/s signal and adjust L2 for maximum meter reading.

Note: The setting of TC2 and mechanical adjustment of L3 coil former have been carefully carried out at the factory for minimum oscillator radiation, and are unlikely to require further attention.

DISMANTLING

Chassis Removal.—To remove the chassis from the cabinet, it is best to place the receiver in a face-downwards position.

Remove the back cover by taking out four Phillips-head screws.

Slide out the heat deflector from inside the top of the cabinet.

Unscrew five screws securing the chassis to the cabinet brackets (screws "A" on main chassis diagram).

Withdraw the chassis complete with control knobs and tuning scale, tilting slightly to allow the glass scale to clear the cabinet brackets. Unplug the loud-speaker leads from the output transformer if required.

V.H.F. Tuner Unit Removal.—To remove the v.h.f. tuner unit, first remove

the chassis as just described.

Disconnect the five soldered connections "a-e" (see f.m. tuner diagram).

Remove the locking screw and washer securing the pivoted calibration adjuster, located in the curved slot of the tuning drum.

Remove the cord loop from the boss on the pivoted adjuster.

Remove two 6BA screws which retain the v.h.f. unit and aerial socket assembly to the tuning capacitor bracket.

Remove the 6BA screw retaining the v.h.f. tuner to the tuning capacitor bracket (top centre of unit) and two 6BA screws retaining the unit to the lower chassis fixing bracket. Lift the unit clear of the chassis.

View of the f.m. tuner unit with the screening cover removed showing component locations and the tuning drive assembly. To fit a new tuning drive (which should be replaced as a complete assembly) see "F.M. Tuning Cord Replacement" in col. 6

