

# BUSH RADIO

## Service Instructions



www.radio-workshop.co.uk

## MODEL VHF.61

FOR A.C. MAINS

### INDEX

Section	Page	Section	Page
Alignment Procedure .. .. .	5	Fig. 1—Circuit Diagram .. .. .	2
Capacitors .. .. .	11	Fig. 2—Under View of Chassis .. .. .	3
Coils, Chokes and Transformers .. .. .	9	Fig. 3—Top View of Chassis .. .. .	4
Cord Drive, Tuning Capacitor, replacing .. .. .	8	Fig. 4—V.H.F. Box — Component Layout .. .. .	6
Cord Drive, VHF, replacing .. .. .	7	Fig. 5—V.H.F. Cord Drive .. .. .	7
Dismantling—removing chassis from cabinet .. .. .	6	Fig. 6—Assembly of Cord Drive .. .. .	8
Mains Transformer, connections to .. .. .	8	Fig. 7—Key to I.F.T. Bases .. .. .	8
Part Numbers, miscellaneous .. .. .	12	Fig. 8—Piano Key Switch—Connections .. .. .	10
Resistors .. .. .	10	and Key .. .. .	
Specification .. .. .	1		
Switch, connections to .. .. .	10		
Valve Voltages .. .. .	9		
VHF Box, removing from chassis .. .. .	6		

### SPECIFICATION

#### BASIC DESIGN

When switched to long or medium waveband the circuit is a conventional 7-valve (including rectifier and tuning indicator) superhet, using Mullard valves in the following sequence :—

Frequency changer ECH 81 (V2), 1st I.F. Amplifier EF 89 (V3), 2nd I.F. Amplifier EF 89 (V4), Detector/AGC Diode and Audio Amplifier EABC 80 (V5), Tuning indicator EM 81 (V6), output EL 84 (V7), Full wave rectifier, EZ 80 (V8).

When switched to the V.H.F. band the circuit is modified by the addition of two further stages. The valve sequence is then :—

V.H.F. Amplifier and Mixer ECC 85 (V1), 1st I.F. Amplifier, Heptode section of ECH 81 (V2), 2nd I.F. Amplifier EF 89 (V3), 3rd I.F. Amplifier EF 89 (V4), Ratio Detector and Audio Amplifier, two diodes and triode of EABC 80 (V5), Tuning Indicator EM 81 (V6), output EL 84 (V7), Full-wave rectifier EZ 80 (V8).

V.H.F. Oscillator and R.F. Tuning is by means of iron-dust cores moved by a cord drive system attached to the spindle of the A.M. tuning capacitor. Separate I.F. transformers are used for A.M. (470 kc/s) and F.M. (10.7 mc/s), and the appropriate set of I.F. Transformers is selected by means of slider switches operated by piano key type push buttons.

Negative feedback over the audio stages is taken from the secondary of the output transformer.

#### VALVES

Mullard Type	Heaters
ECC 85 (V1)	6.3V. 0.435A.
ECH 81 (V2)	6.3V. 0.3A.
EF 89 (V3)	6.3V. 0.2A.
EF 89 (V4)	6.3V. 0.2A.
EABC 80 (V5)	6.3V. 0.45A.
EM 81 (V6)	6.3V. 0.3A.
EL 84 (V7)	6.3V. 0.76A.
EZ 80 (V8)	6.3V. 0.6A.

#### VOLTAGE RANGE

100/120V. and 200/250V. 40 to 100 c/s.

#### MAINS CONSUMPTION

65 watts approximately.

#### SCALE LAMPS

1 at 6.5V. 0.3A.

#### AUDIO OUTPUT

2.5 watts approximately.

#### WAVEBANDS

Long ..	280 kc/s—158 kc/s	1,070—1,900 metres.
Medium	1,604 kc/s—535 kc/s	187— 560 „
V.H.F. ...	87.5 mc/s—100 mc/s	3.4— 3 „

#### INTERMEDIATE FREQUENCIES

A.M.—470 kc/s.

V.H.F.—10.7 mc/s.

#### CONTROLS (from left to right)

(a) Concentric control, tone outer, volume inner.

(b) Piano keys OFF, GRAM, V.H.F., M.W., L.W.

(c) Tuning.

#### GRAMOPHONE PICK-UP

The pick-up sockets are situated at the back of the chassis on the left.

#### AERIAL CONNECTIONS

L and M—an internal ferrite rod aerial is fitted, which is permanently connected. Sockets are also provided for an external aerial if desired.

V.H.F.—a loaded dipole is fitted to the cabinet back. This is connected to the receiver by means of an 80Ω line and 2-pin plug. An external aerial may be employed if necessary.

#### EXTERNAL SPEAKER

Use a permanent magnet speaker (approx. 2.5Ω impedance) and connect to the two sockets at the back of the chassis on the right.

#### CABINET DIMENSIONS

Height 11¼ ins. Depth 7¼ ins. Width 16¼ ins.

CONDENSERS	1	2	3	4	5	6	7	8	9	10	11	12	13	14	15	16	17	18	19	20	21	22	23	24	25	26	27	28	29	30	31	32	33	34	35	36	37	38	39	40	41	42	43	44	45	46	47	48	49	50	51	52	53	54	55	56	57	58	59	60
RESISTORS	1	2	3	4	5	6	7	8	9	10	11	12	13	14	15	16	17	18	19	20	21	22	23	24	25	26	27	28	29	30	31	32	33	34	35	36	37	38	39	40	41	42	43	44	45	46	47	48	49	50	51	52	53	54	55	56	57	58	59	60



RECEIVER SWITCHED TO VHF

VOLTAGES GREATER THAN 10V MEASURED ON AVO MODEL 7, 1000V RANGE  
 VOLTAGES LESS THAN 10V MEASURED ON AVO MODEL 7, 10V RANGE  
 READINGS MARKED F.M. WILL BE OBTAINED WITH WAVE CHANGE SWITCH  
 IN F.M. POSITION. ALL OTHER READINGS TAKEN WITH SWITCH IN M.W. POSITION

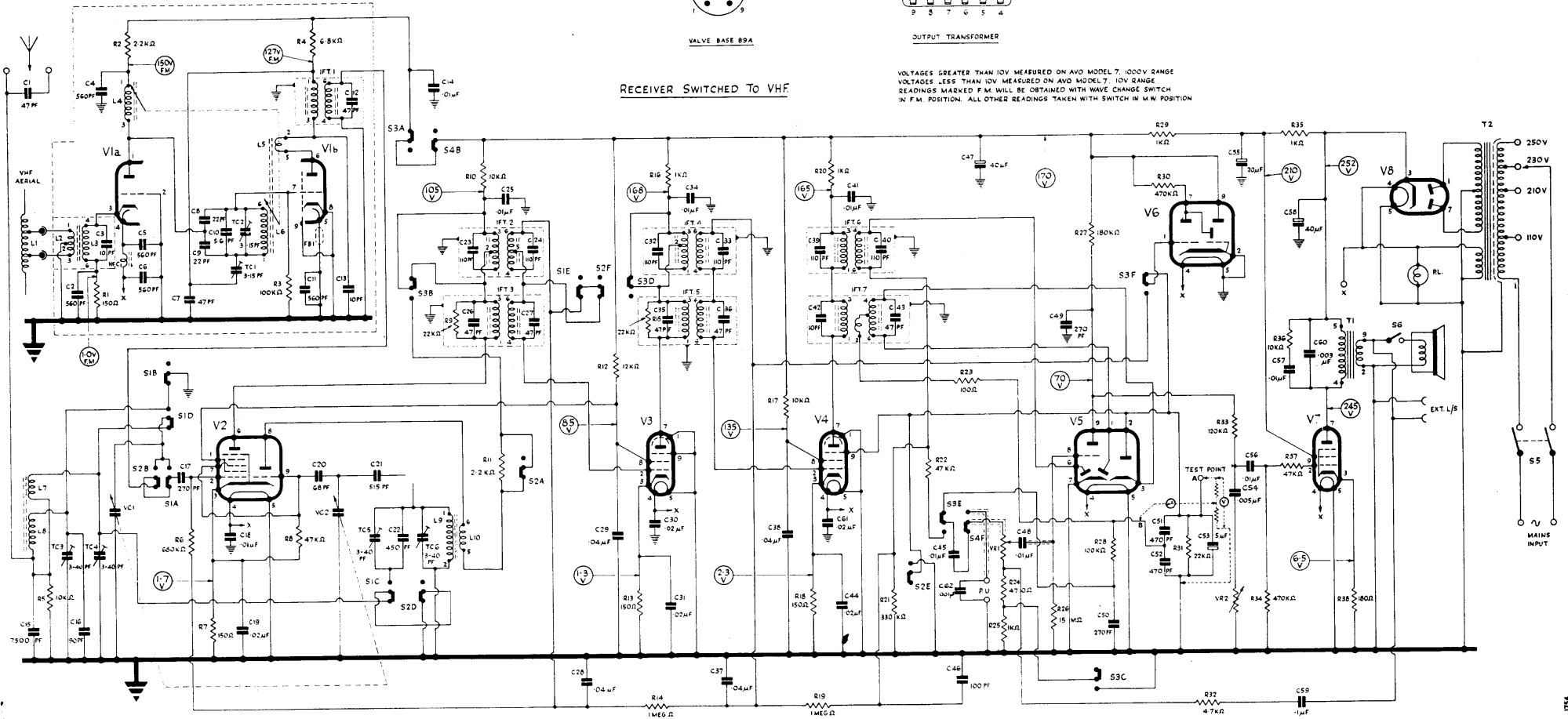

Page 2

CONDENSERS	15	16	17	18	19	20	21	22	23	24	25	26	27	28	29	30	31	32	33	34	35	36	37	38	39	40	41	42	43	44	45	46	47	48	49	50	51	52	53	54	55	56	57	58	59	60										
RESISTORS	5	6	7	8	9	10	11	12	13	14	15	16	17	18	19	20	21	22	23	24	25	26	27	28	29	30	31	32	33	34	35	36	37	38	39	40	41	42	43	44	45	46	47	48	49	50	51	52	53	54	55	56	57	58	59	60

Fig. 1 — Circuit Diagram

1754

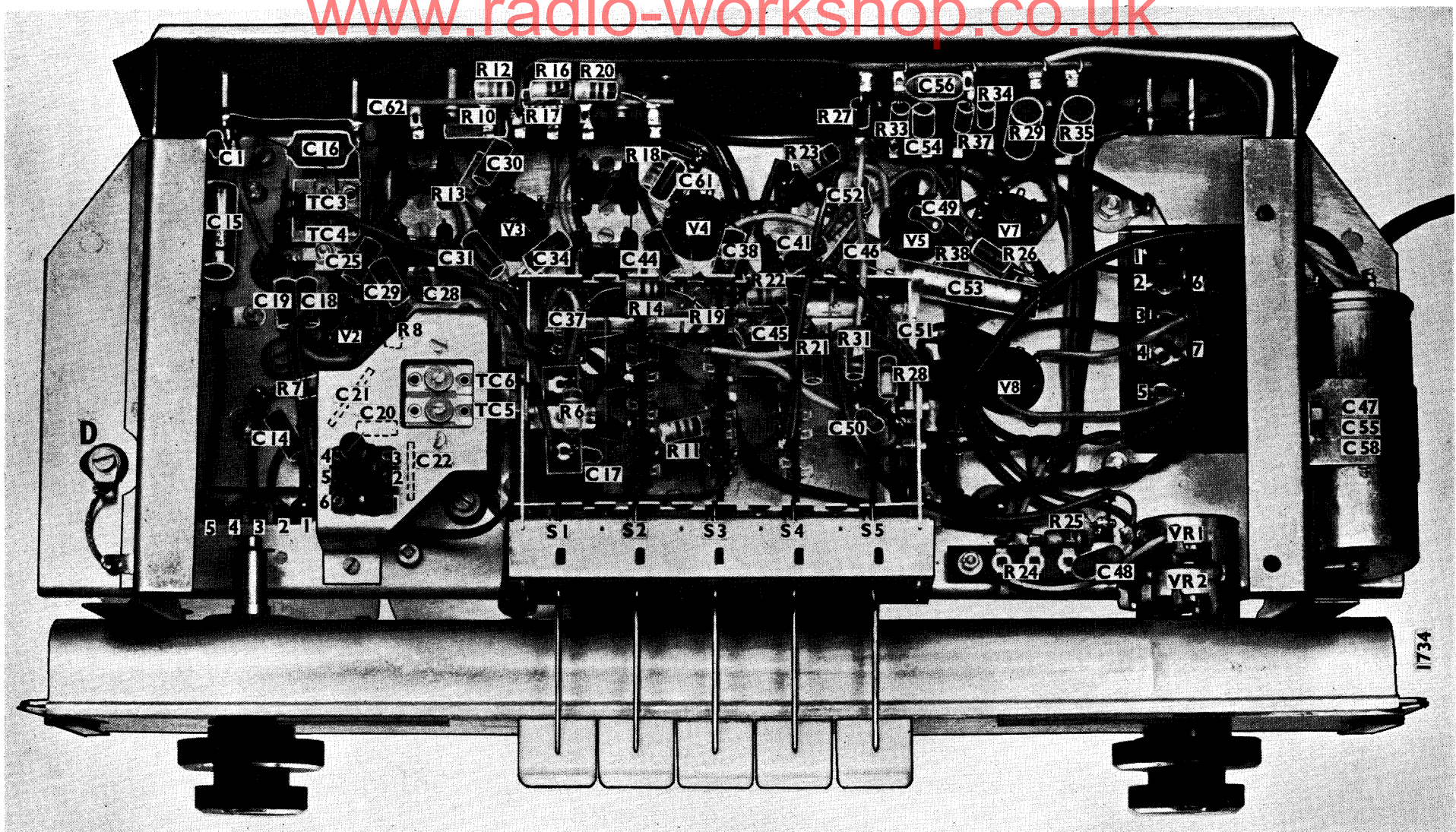

Fig. 2—Under View of Chassis. See fig. 1 for number references

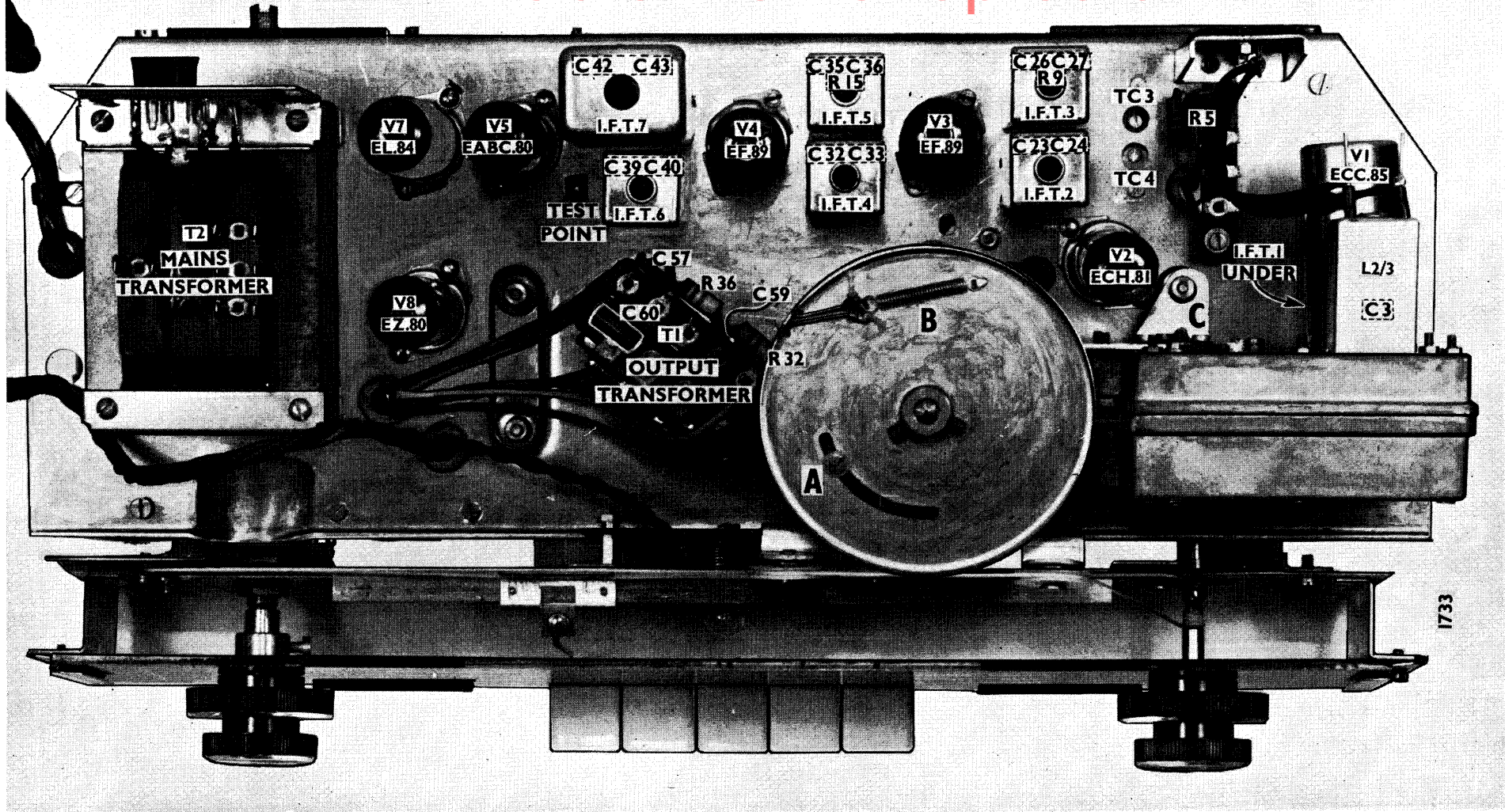

Fig.3—Top View of Chassis

## ALIGNMENT INSTRUCTIONS

## GENERAL

- (a) Remove receiver from cabinet.  
 (b) The receiver and signal generator should be switched on 15 minutes before alignment is attempted.
- (c) Use a non-metallic trimming tool.  
 (d) IFT.7 has the secondary at the bottom of the can. All other IFT's have secondaries at the top.

## A.M.

## I.F. Alignment (470 kc/s)

- (a) Switch the receiver to M.W. and set pointer to approximately 300 metres. Inject 470 kc/s signal 30% modulated at 400 c/s between pin 2, V4 and chassis, and connect the output meter to the secondary of T.I. Disconnect the speech coil.  
 (b) Tune Sec. and Pri. IFT.6 (in that order) for maximum audio output.  
 (c) Transfer generator to pin 2, V3, and tune Sec. and Pri. IFT.4 (in that order) for maximum audio output.  
 (d) Transfer generator to pin 2, V2, and tune Sec. and Pri. IFT.2 (in that order) for maximum audio output.

## R.F. Alignment

With generator still connected to pin 2, V2, align as follows :—

Operation	Waveband	Generator (kc/s)	Receiver Calibration	Adjust for Maximum Audio Output
1	M.W.	600	500 metres	L9 & 10 (Osc.)
2	M.W.	1,500	200 metres	TC6 (Osc.)
3	Repeat operations 1 and 2—check calibration			
4	L.W.	214	1,400 metres	TC5 (Osc.)

For the adjustment of TC4 and TC3 (trimmers on ferrite rod aerial) it is necessary to couple the generator by means of a single turn loop of wire approximately 5" in diameter, positioned 12" to 18" away from the cabinet.

Operation	Waveband	Generator (kc/s)	Receiver Calibration	Adjust for Maximum Audio Output
5	M.W.	1,500	200 metres	TC4 (Aerial)
6	L.W.	214	1,400 metres	TC3 (Aerial)

## V.H.F.

Equipment required :—

- (1) Signal Generator for 10.7 mc/s (I.F.) and 87.5 to 100 mc/s.  
 (2) AVOMeter Model 8  
 or  
 D.C. Valve-Voltmeter.  
 (3) Two 47k  $\frac{1}{2}$  watt resistors, matched.  
 (4) One 1k  $\frac{1}{2}$  watt resistor.

## I.F. Alignment (10.7 mc/s)

Switch receiver to V.H.F. band. Connect the two 47k resistors in series between test point "A" and chassis. Connect the AVO model 8 (on 10v. D.C. range) or the valve-voltmeter across the two resistors.

NOTE.—With the exception of the discriminator (IFT.7) primary, the correct peak associated with all cores is the first one reached :—

- (a) From the top of the coil former as the core enters the secondary winding ;  
 (b) From the base of the coil former as the core enters the primary winding.
- (a) Adjust, if necessary, the position of the I.F. cores as follows :—  
 IFT.3 and IFT.5—primary and secondary cores to be  $\frac{1}{8}$ " inside coil former.  
 IFT.7 Primary—core to be  $\frac{3}{8}$ " inside coil former.  
 IFT.7 Secondary—core to be  $\frac{3}{8}$ " inside coil former.
- (b) Inject 10.7 mc/s unmodulated to pin 2, V3, and turn volume control to minimum. Adjust the input level to produce an output of 4v. D.C. across the voltmeter. During alignment the input signal should be maintained at a level just sufficient to produce 4v. D.C. each time a trimming adjustment is made to any core.
- (c) Adjust Pri. IFT.7 for maximum D.C. output.  
 (d) Connect 1,000 $\Omega$  damping across Sec. IFT.5 and adjust Pri. for maximum D.C. output. Transfer damping to Pri. and adjust Sec. for maximum D.C. output. Remove damping.  
 (e) Transfer signal to pin 2, V2. Connect damping across Sec. IFT.3 and adjust Pri. for maximum D.C. output.

Transfer damping to Pri. and adjust Sec. for maximum D.C. output. Remove damping.

- (f) Readjust Pri. IFT.7 for maximum D.C. output.  
 (g) Connect the AVO (on 50 $\mu$ A range) or microammeter between the junction of the two 47k resistors and point B (see circuit diagram). Adjust Sec. IFT.7 for zero on the microammeter.

NOTE.—Zero response can only occur when the Sec. IFT.7 is in balance. When it is off tune either positive or negative output will be obtained. The AVO Model 8 has a reversing button to allow reading in either direction, but with a microammeter the connections would need reversing.

- NOTE.—It is essential that maximum D.C. output coincides with minimum response on the microammeter.  
 (h) Transfer signal input to V.H.F. aerial sockets and adjust sec. IFT.1 for maximum D.C. output.

## R.F. Alignment

- (a) Set generator and auxiliary pointer to 88 mc/s. Slacken the locking screw on the pivoted adjuster (fig. 3) and rotate arm for maximum D.C. output. This operation adjusts the cores of L4 (R.F.) and L5/L6 (Osc.). Tighten locking screw.  
 (b) Set generator and auxiliary pointer to 94 mc/s and adjust L2/L3 (aerial) for maximum D.C. output.  
 (c) Check calibration.

NOTE.—No reference has so far been made to the trimmers TC1 and TC2 (fig. 2). TC1, the oscillator bridge balancing trimmer, has been adjusted in production for minimum transmission of oscillator voltage to the V.H.F. aerial sockets.

TC2, the oscillator trimmer, has been similarly adjusted for optimum V.H.F. calibration.

As these trimmers are set up using special alignment gear and subsequent variation is unlikely, no readjustment should be necessary in future.

Replacement of V1 (ECC85) may cause slight changes in oscillator calibration. If so, the pivoted adjuster should be reset as detailed above.

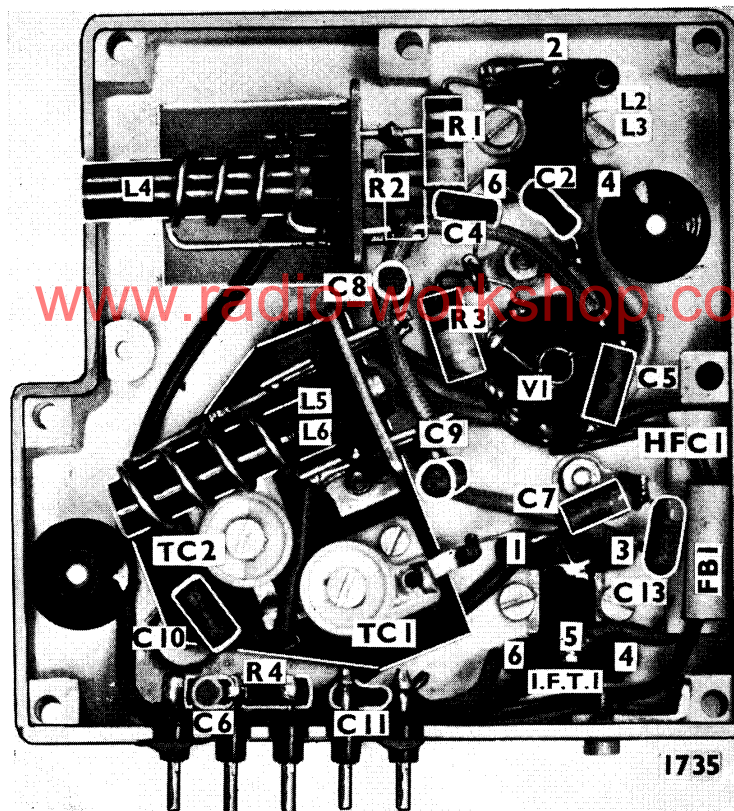

Fig. 4—VHF Box—Component Layout. See fig. 1 for number references

### DISMANTLING

#### REMOVING V.H.F. BOX FROM CHASSIS

- (1) Unsolder the five connections to the box (see below).
- (2) Set the tuning capacitor to minimum and unhook the spring (B, fig. 3) from the drive drum.
- (3) Remove the cord drive from the drive drum.
- (4) Release and remove the screw and washer (A, fig. 3) from the pivoted adjuster.
- (5) Unbolt and remove the drive drum.
- (6) Remove the cord from around the brass boss.
- (7) Remove the three bolts holding the box to the L-shaped bracket (C, fig. 3) and remove the bolt (D, fig. 2) from beneath the chassis.

#### CONNECTIONS TO V.H.F. BOX (Fig. 2)

1. S3A.
2. Pin 4V2.
3. Chassis.
4. S2B.
5. Chassis.

#### REMOVING OSCILLATOR DECK

1. Remove black lead from S1.C.
2. Remove green lead from stator VC2.
3. Remove green lead from Pin 7, V2.
4. Remove blue lead from Pin 8, V2.
5. Remove pink lead from S2A.
6. Unbolt and remove oscillator deck.

#### REMOVING CHASSIS FROM CABINET

1. Remove cabinet back.
2. Remove the four chassis fixing bolts underneath the cabinet and the two bolts holding the chassis fixing brackets to the left and right inside walls of the cabinet.
3. Remove the ferrite rod by gently dislodging the rubber grommets from the metal brackets.
4. Loosen the nut holding the cleat on the top left hand corner of the loudspeaker and slip the tuning indicator leads out from under it. These leads, when freed from the cleat, are long enough to enable the chassis to be removed, but if it is required to separate the chassis entirely from the cabinet, grasp the tuning indicator firmly in the hand and lever its holder clear of the locating notch in the baffle and slide it downwards clear of the spring.
5. Unscrew the spade tags connected to pin 1 and pin 2 of the output transformer (see fig. 3).

## REPLACING VHF TUNING CORD DRIVE

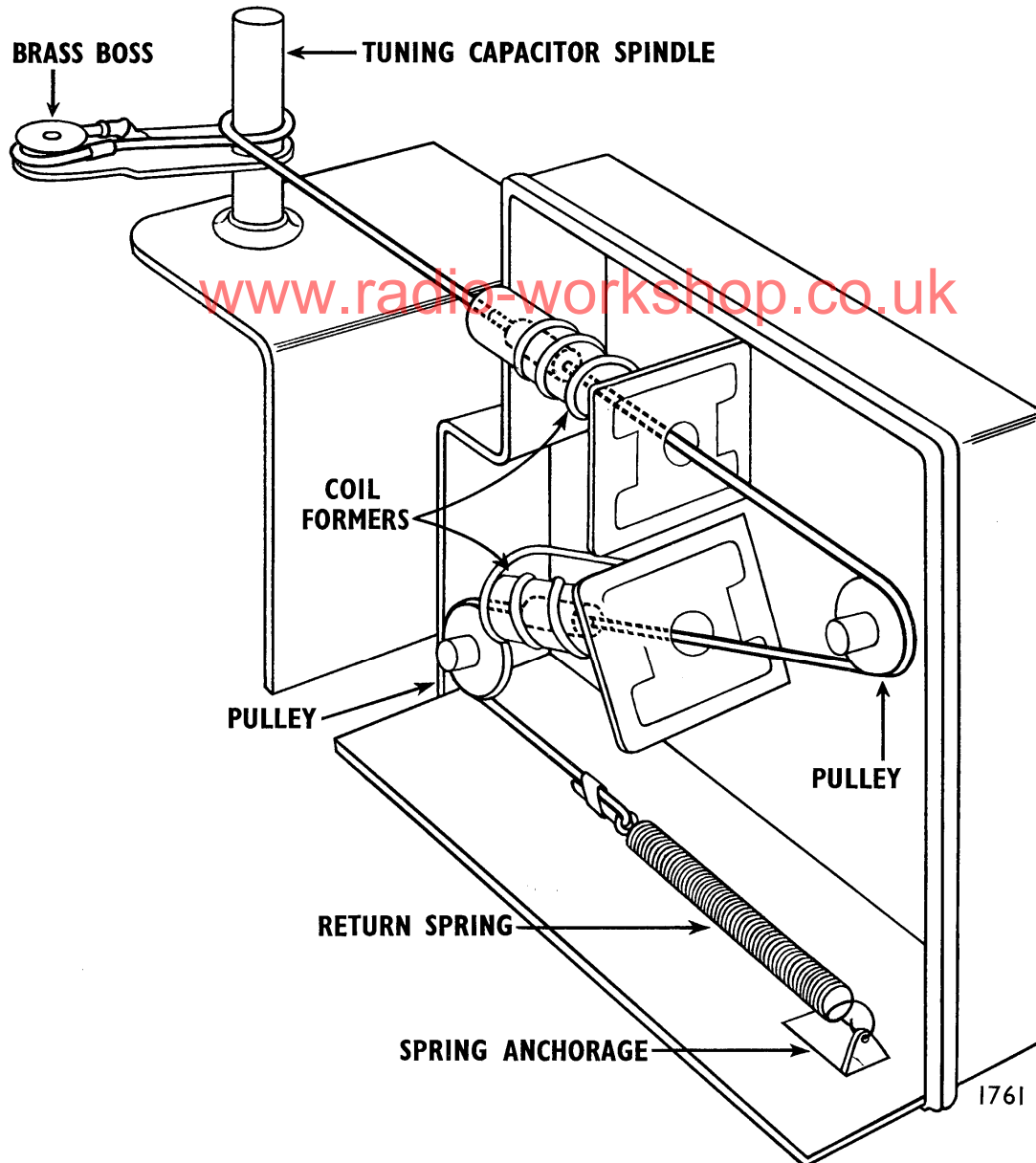

Fig. 5—VHF Cord Drive

Should a breakage occur in either cords or cores it is recommended that the complete assembly (AP24888) should be obtained and fitted as follows:—

1. Remove front side of V.H.F. box. To do this it is first necessary to remove the tuning scale (see Instructions for Replacing Tuning Capacitor Cord Drive, page 8), then the screws holding the front side of the box may be removed.
2. Set the tuning capacitor to minimum to ease tension on the return spring in the V.H.F. box.
3. Unhook the spring (B, fig. 3) from the drive drum.
4. Remove the cord drive from the drive drum.
5. Release and remove the screw and washer (A, fig. 3) from the pivoted adjuster.
6. Unbolt and remove the drive drum.
7. Thread assembly of tuning cores (fig. 5) through coil formers and hook the spring to its anchorage.
8. Now take one turn in a clockwise direction around the tuning capacitor spindle and slip the loop in the cord over the brass boss.
9. Re-positioning the drive drum should present no difficulty if it is noted that the gap in the edge of the drive drum (through which the drive cord passes) should be immediately above the visible part of the V.H.F. tuning cord when the ganged capacitor is at maximum capacity. Check that the pointer coincides with the dots at the right hand end of the scale.
10. Re-set pivoted adjuster as laid down in the alignment procedure for V.H.F.

## PART NUMBERS

Assembly of Tuning Cores	..	..	..	..	AP24888
Pulley	..	..	..	..	AP24684
Spring, cord tension	..	..	..	..	AP24740

REPLACING TUNING CAPACITOR CORD DRIVE

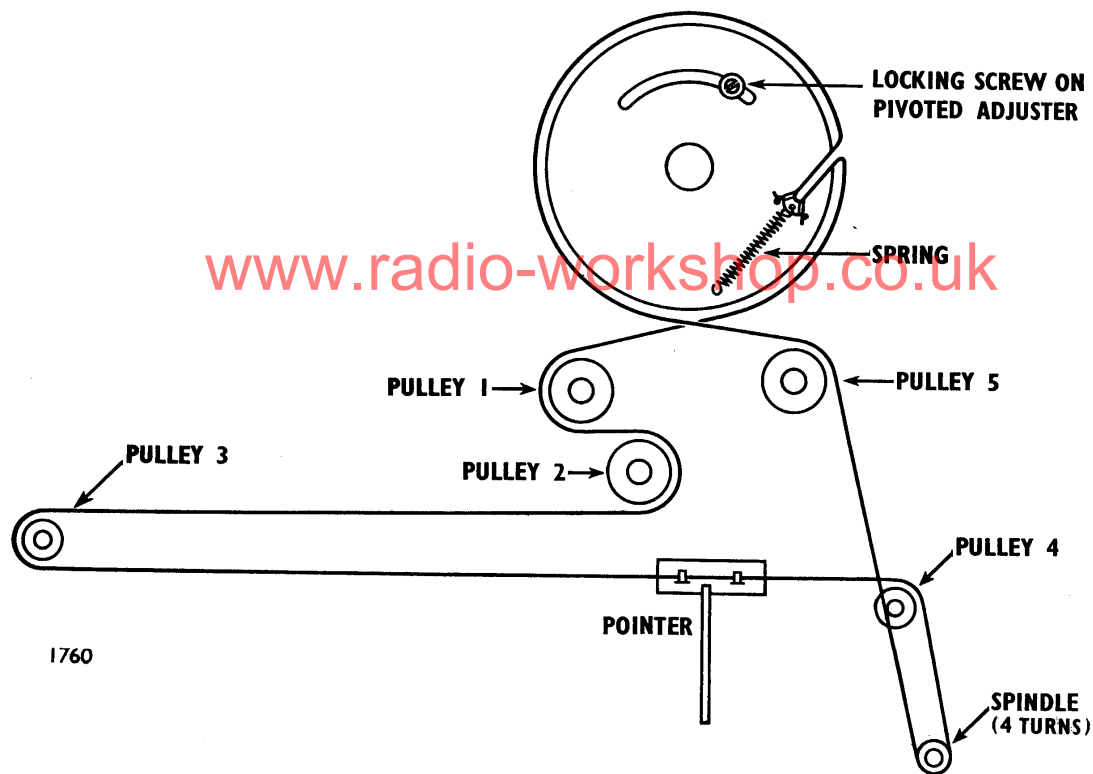

Fig. 6— Assembly of Cord Drive

To replace the cord drive or to remove the front side of the V.H.F. box, the tuning scale must first be removed. This is done as follows : First remove the control knobs by loosening the retaining grub screws and sliding the knobs off their spindles. Both knobs are in two parts, each fixed to the spindle by a separate grub screw. Next remove the screws holding the scale-retaining clamps at either end of the scale. Now tilt the scale forward so as to bring it clear of the control spindles and carefully withdraw it, avoiding the piano keys.

The diagram (fig. 6) shows the position of the drive drum with the tuning capacitor at maximum. The length of glass nylon cord required is approximately 48 inches.

Pass the cord around pulley 1 counter-clockwise, then round pulley 2 clockwise, then round pulley 3 counter-clockwise, then round pulley 4 clockwise, then take 4 turns clockwise round the tuning knob spindle, then counter-

clockwise round pulley 5, then around the drum clockwise to the opening. Take the other end of the cord from pulley 1 around the drum counter-clockwise and clench both ends in the clip, hook the clip to the spring and attach the other end of the spring to the lug on the drive drum.

Set the pointer to the dots at the right hand end of the scale and clench the two lugs over the drive cord.

Carriage . . . . .	AP24797
Clip, Cord Drive . . . . .	P1940
Cord Drive assembly (including clip, spring and cord) . . . . .	AP24899
Drum, drive . . . . .	AP24792
Pointer . . . . .	AP24798
Pulley (small) . . . . .	AP24684
Pulley . . . . .	AP12416
Spring . . . . .	P1941

CONNECTIONS TO MAINS TRANSFORMER  
(Part No. AS25716)

External connections are made to the tags on the base of the transformer (fig. 2) as follows :—

Tag No.	To
1	Chassis
2	Pin 4, V7
3	Pin 7, V8
4	Pin 5, V8
5	Pin 1, V8
6	S5
7	S5

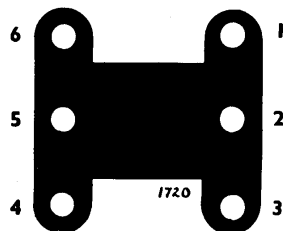

Fig.7—Key to I.F.T. Bases  
Under View from rear of chassis

## COILS, CHOKES AND TRANSFORMERS

Reference	Resistance (ohms)	Part Number	Description
L1	Less than 0.5	AS24894	V.H.F. Aerial loading coil.
L2	" " "	CS24884	V.H.F. Aerial coil.
L3	" " "		
L4	" " "		
L5	" " "	BS24883	V.H.F. Oscillator coil.
L6	" " "		
L7	" " "	DS25698	M.W. Ferrite aerial coil. L.W. Ferrite aerial coil.
L8	13		
L9	4	BS25714	M.W./L.W. Oscillator coil.
L10	1		
HFC1	Less than 0.5	AS24886	Heater choke.
IFT.1	Pri. less than 0.5 Sec. less than 0.5	BS24879	1st V.H.F. I.F.T.
IFT.2	Pri. 14 Sec. 14	CS24880	1st A.M. I.F.T.
IFT.3	Pri. less than 0.5 Sec. less than 0.5	BS24878	2nd V.H.F. I.F.T.
IFT.4	Pri. 14 Sec. 14	CS24881	2nd A.M. I.F.T.
IFT.5	Pri. less than 0.5 Sec. less than 0.5	BS24878	3rd V.H.F. I.F.T.
IFT.6	Pri. 14 Sec. 14	BS24304	3rd A.M. I.F.T.
IFT.7	Pri. less than 0.5 Sec. 1 less than 0.5 Sec. 2 less than 0.5	CS24882	V.H.F. Discriminator Trans.
T.1	Pri. 380 Sec. less than 0.5	AS25716	Output Transformer.
T.2	Pri. 20 Sec. 220	DS25721	Mains Transformer.

## VALVE VOLTAGES AND CURRENTS (see Fig. 1)

Valve	Anode Volts	Screen Volts	Cathode Volts	Cathode Currents
V1A } ECC85	150	—	1.0	6.7 mA.
V1B }	127	—	—	6.3 mA.
V2 (ECH81)	Heptode 105	85	1.7	11.3 mA.
V3 (EF89)	168	85	1.3	8.7 mA.
V4 (EF89)	165	135	2.3	15.3 mA.
V5 (EABC80)	70	—	—	—
V6 (EM81)	170	—	—	—
V7 (EL84)	245	210	6.5	36 mA.
V8 (EZ80)	—	—	252	—

The above-mentioned circuit diagram quotes the conditions under which these readings were taken. Limited variations may occur without impairing the performance of the receiver.

CONNECTIONS TO PIANO-KEY SWITCH UNIT

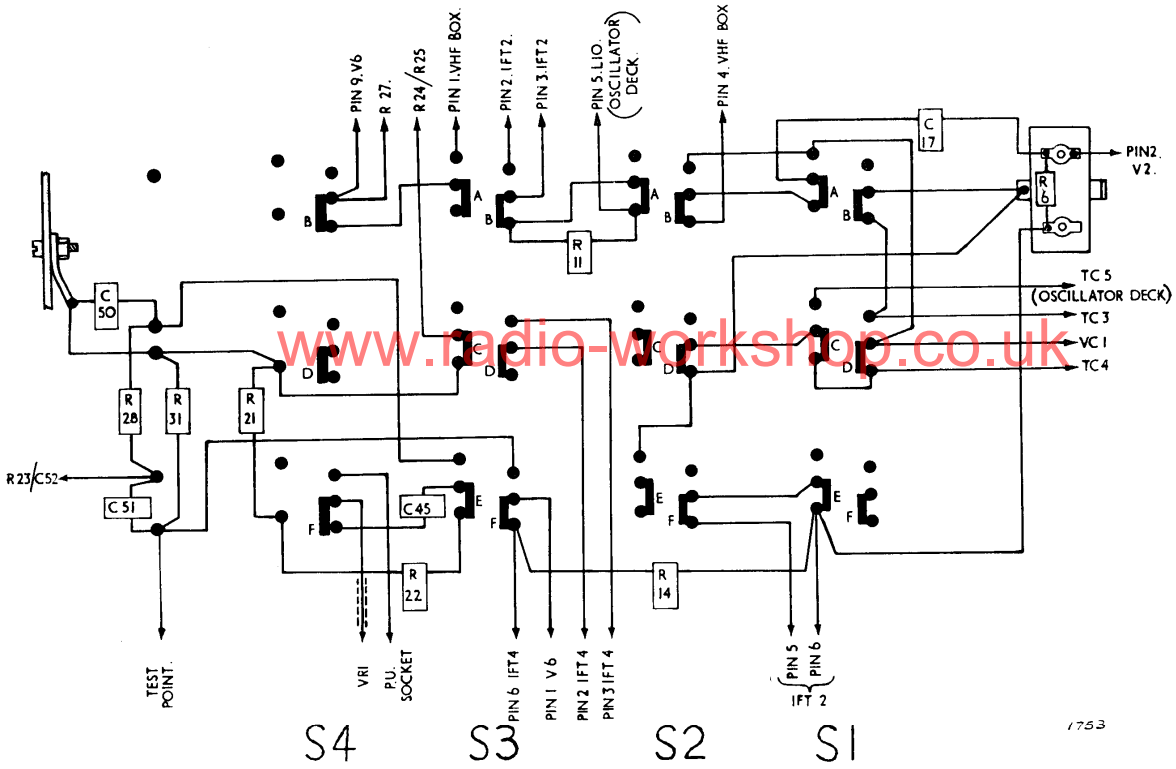

Fig. 8—Connections and key to switch tags

RESISTORS

Ref.	Value (ohms)	Rating (Watts)	Tolerance ± %	Part No.
R1	150	1	10	P6155
R2	2,200	1	10	P6449
R3	100,000	1	10	P6869
R4	6,800	1	10	P6574
R5	10,000	1	20	P6611
R6	680,000	1	20	P7073
R7	150	1	20	P6155
R8	47,000	1	20	P6779
R9	22,000	1	10	P6701
R10	10,000	1	10	P6616
R11	2,200	1	5	P6455
R12	12,000	1	10	P6635
R13	150	1	10	P6155
R14	1 meg.	1	20	P7115
R15	22,000	1	10	P6701
R16	1,000	1	20	P6359
R17	10,000	1	10	P6617
R18	150	1	10	P6155
R19	1 meg.	1	20	P7115
R20	1,000	1	20	P6359
R21	330,000	1	20	P6989
R22	47,000	1	20	P6779
R23	100	1	20	P6107
R24	470	1	10	P6281
R25	1,000	1	10	P6365
R26	15 meg.	1	33½	P14548
R27	180,000	1	20	P14227
R28	100,000	1	20	P6863
R29	1,000	6	5	AP25615 W.W.
R30	470,000	6	20	P7031
R31	22,000	6	10	P6701
R32	4,700	6	10	P6533
R33	120,000	6	20	P14197
R34	470,000	6	20	P7031
R35	1,000	6	5	AP25615 W.W.
R36	10,000	6	20	P6611
R37	47,000	6	20	P6779
R38	180	6	5	P6178
VR1	1 meg.	6	—	BP24793
VR2	1 meg.	6	—	

## CAPACITORS

Ref.	Value		Type	D.C. Working Voltage	Tolerance ± %	Part No.
	mfd.	pf.				
C1	—	47	S.C.	750	20	AP17338
C2	—	560	S.C.	350	20	AP23405
C3	—	10	S.M.	350	5	AP18211
C4	—	560	S.C.	350	20	AP23405
C5	—	560	S.C.	350	20	AP23405
C6	—	560	S.C.	350	20	AP23405
C7	—	47	S.C. (N750)	750	5	AP24630
C8	—	22	S.C. (P100)	750	2	AP24626
C9	—	22	S.C. (P100)	750	2	AP24626
C10	—	5.6	S.C. (N750)	750	± .5pf.	AP24628
C11	—	560	S.C.	350	20	AP23405
C12	—	47	S.M.	350	5	AP24848
C13	—	10	S.C. (N750)	750	5	AP24629
C14	.01	—	M.P.	400	20	AP21909
C15	—	7,500	P.F.T.	350	5	AP25617
C16	—	90	S.M.	350	2	AP15697
C17	—	270	S.C.	500	20	AP21906
C18	.01	—	M.P.	400	20	AP21909
C19	.02	—	M.P.	150	20	AP22251
C20	—	68	S.C.	750	20	AP18161
C21	—	515	S.M.	350	1	AP17175
C22	—	450	S.M.	350	1	AP25616
C23	—	110	S.M.	350	2	AP25808
C24	—	110	S.M.	350	2	AP25808
C25	.01	—	M.P.	400	20	AP21909
C26	—	47	S.M.	350	5	AP24848
C27	—	47	S.M.	350	5	AP24848
C28	.04	—	M.P.	200	20	AP24028
C29	.04	—	M.P.	200	20	AP24028
C30	.01	—	M.P.	400	20	AP21909
C31	.02	—	M.P.	150	20	AP22251
C32	—	110	S.M.	350	20	AP25808
C33	—	110	S.M.	350	20	AP25808
C34	.01	—	M.P.	400	20	AP21909
C35	—	47	S.M.	350	5	AP24848
C36	—	47	S.M.	350	5	AP24848
C37	.04	—	M.P.	200	20	AP24028
C38	.04	—	M.P.	200	20	AP24028
C39	—	110	S.M.	350	2	AP25808
C40	—	110	S.M.	350	2	AP25808
C41	.01	—	M.P.	400	20	AP21909
C42	—	10	S.M.	350	5	AP24847
C43	—	47	S.M.	350	5	AP24848
C44	.02	—	M.P.	150	20	AP22251
C45	.01	—	P.T.	350	20	AP24117
C46	—	100	S.C.	750	20	AP17336
C47*	40	—	ELEC.	350	-20	AP22257*
C48	.01	—	P.T.	350	+50	AP24117
C49	—	270	S.C.	500	20	AP21906
C50	—	270	S.C.	500	20	AP21906
C51	—	470	S.C.	500	20	AP24631
C52	—	470	S.C.	500	20	AP24631
C53	5	—	ELEC.	50	-20	AP22255
C54	.005	—	P.T.	500	+50	P3767
C55*	20	—	ELEC.	350	-20	*
C56	.01	—	P.T.	350	+50	AP24117
C57	.01	—	P.T.	500	25	P3769
C58*	40	—	ELEC.	350	-20	*
C59	.1	—	M.P.	150	+50	AP21245
C60	.003	—	M.P.	300 A.C.	20	AP23978
C61	.02	—	M.P.	150	20	AP22251
C62	.001	—	M.P.	400	20	AP22248
TC1	—	3 to 15	—	—	—	AP24623
TC2	—	3 to 15	—	—	—	AP24623
TC3	—	3 to 40	—	—	—	AP24820
TC4	—	3 to 40	—	—	—	AP24820
TC5	—	3 to 40	—	—	—	AP24820
TC6	—	3 to 40	—	—	—	AP24820
VC1	—	528	} Ganged	—	—	BP23657
VC2	—	528		—	—	

\* In same can.

Elec. = Electrolytic. M.P. = Metalized Paper. P.T. = Paper Tubular. S.C. = Silver Ceramic. S.M. = Silver Mica.

NOTE.—It will be noticed that C11 in the V.H.F. box is shorted out. To ensure efficient quantity production it has been found necessary to produce the V.H.F. box as a unit common to this and similar models and to others using a series heater chain. When it is used on an A.C. set like this one it is modified by shorting the filter capacitor as shown.

## MISCELLANEOUS PART NUMBERS

Description	Part No.	Description	Part No.
Aerial, ferrite .. .. .	DS25698	Plug, black .. .. .	P3734
Back, Cabinet .. .. .	DS25700	Plug, 2-pin .. .. .	AP20161
Carriage .. .. .	AP24797	Rod, ferrite .. .. .	DS25698
Clip, cord .. .. .	P1940	Scale, tuning .. .. .	DP24787
Cord Drive Assy. .. .. .	AP24899	Socket .. .. .	P8231
Core, ferroxcube (FB1) .. .. .	AP22966	Speaker, elliptical .. .. .	BP24776
Knob, Tone (Outer) .. .. .	AS25771	Switch, piano key .. .. .	EP24782
Knob, Volume (Inner) .. .. .	AS25741	Valveholder B9A .. .. .	AP22419
Knob, Tune .. .. .	AS25743	Valveholder with skirt B9A .. .. .	AP22843
Knob (Piano Key) .. .. .	CP24670	Valveholder B9A (moulded) .. .. .	AP25591
Lamp, pilot, 6.5v. 0.3a. .. .. .	AP18628	Valve Screening Can (with spring) .. .. .	AP22842
Plug, red .. .. .	P3733		

[www.radio-workshop.co.uk](http://www.radio-workshop.co.uk)

*Issued by the Technical Publications Department of*

BUSH RADIO LIMITED · POWER ROAD · CHISWICK · LONDON · W.4

*All enquiries to be made to the SERVICE DEPARTMENT*

**BUSH RADIO LIMITED**

KEW WORKS · MORTLAKE ROAD · KEW · RICHMOND · SURREY

Telephone: PROspect 8271/4

# BUSH RADIO

## Service Instructions

MODEL VHF. 62 [www.radio-workshop.co.uk](http://www.radio-workshop.co.uk)

### Radio Receiver

Supplement to TP1082



#### GENERAL DESCRIPTION

##### CABINET

Walnut-veneer cabinet with gilt trim.

VHF. 62

##### DIMENSIONS

Height,  $11\frac{7}{8}$  in. 30.4 cm.

Width,  $18\frac{3}{4}$  in. 47.7 cm.

Depth, 9 in. 22.8 cm.

##### WEIGHT

$19\frac{1}{4}$  lb. 8.83 kg.

#### SERVICING

Electrically, the VHF.62 is identical to the VHF.61 and the manual for that receiver (TP1082) should be referred to for all servicing information.

#### PART NUMBERS DIFFERING FROM VHF.61

Description	Part Number
Cabinet	FP70106.
Cabinet back	EP70111.

*Issued by the Technical Publications Department of*  
BUSH RADIO LIMITED

*All enquiries to be made to the SERVICE DEPARTMENT*

**BUSH RADIO LIMITED**

KEW WORKS · MORTLAKE ROAD · KEW · RICHMOND · SURREY

Telephone: PROspect 8271/4