

BUSH RADIO

Service Instructions

www.radio-workshop.co.uk

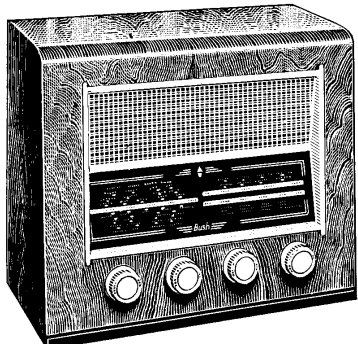

FRONT VIEW OF AC/DAC41

MODEL AC41

for A.C. Mains

100 - 250 Volts 40 - 100 Cycles

MODEL DAC41

for A.C./D.C. Mains

200 - 250 Volts 40 - 100 Cycles

INDEX

Section	Page	Section	Page
Capacitors, Fixed and Variable	2	Speaker	3
Circuit Alignment	3	Specification	1
Coils, Chokes and Transformers	3	Valve Voltage Data	3
Coil Deck Connections	10	Warning	9
Connections to Mains Transformer	9	Illustrations :	
Connections to I.F. Transformers	9	Cord Drive	9
Dismantling	3	Coil Deck (Schematic Drgs.)	10
Fitting Cord Drive	9	View of Coil Deck	8
Gramophone Pick-up	3	Top View of Chassis	6
Modifications	9	Underview of Chassis	7
Part Numbers	9	Circuit Diagram (Encl.)	4&5
Resistors, Fixed and Variable	2		

SPECIFICATION

BASIC DESIGN

A four-valve (including rectifier) three waverange superheterodyne receiver, employing Mullard Rimlock valves in the following sequence: Frequency-changer ECH42 (UCH42), I.F. Amplifier, Signal Rectifier and A.V.C. Delay diode EBF80 (UBF80). Output Stage EL41 (UL41), feeding a high flux elliptical speaker. For record reproduction, the triode section (oscillator) of the frequency-changer valve is used as a first audio amplifier. Model AC41 employs a double wound mains transformer to supply the valve heaters and rectifier, EZ40 (UY41), whilst this is replaced by a mains input unit, consisting of a ballast resistor and R.F. filter, on Model DAC41. The valve types indicated in brackets are for use on the DAC41 model. Adjustable iron dust cored coils are used in the aerial, oscillator and I.F. circuits.

VALVES : AC41

Mullard ECH42	Heater 6.3V.	Heater current 0.23A.
" EBF80	" "	" " 0.3A.
" EL41	" "	" " 0.7A.
" EZ40	" "	" " 0.6A.

DAC41

Mullard UCH42	Heater 14V.	Heater current 0.1A.
" UBF80	" 17V.	" " 0.1A.
" UL41	" 45V.	" " 0.1A.
" UY41	" 31V.	" " 0.1A.

VOLTAGE RANGE

Model AC41 : 100-120V. and 200-250 volts A.C., 40-100 cycles.
Model DAC41 : 200-250 Volts A.C./D.C., 40-100 cycles.

MAINS CONSUMPTION

Approximately 45 watts.

SCALE LAMPS

Model AC41 : 6.2 volts .3 amp.
Model DAC41 : 3.5 volts 0.15 amp.

AUDIO OUTPUT

Approximately 2 watts.

WAVERANGES

Long Wave : 300 Kc/s-150 Kc/s. 1,000-2,000 metres.
Medium Wave : 1,700 Kc/s-520 Kc/s. 176-575 metres.
Short Wave : 21 Mc/s-8.5 Mc/s. 14.3-35.5 metres.

INTERMEDIATE FREQUENCY

470 Kc/s.

CONTROLS (from L. to R.)

Tone.
On/Off Switch and Volume.
Tuning.
Waverange/Gramophone Switch.

GRAMOPHONE PICK-UP

The pick-up sockets are situated on the left-hand side of the receiver (rear view), next to the aerial and earth sockets.

AERIAL AND EARTH

Sockets for aerial and earth connections are situated on a panel on the left-hand side of the receiver (rear view).

CABINET DIMENSIONS

Height 13 $\frac{3}{4}$ ". Depth 7 $\frac{3}{4}$ ". Width 16".

WEIGHT

Approximately 15 lbs.

CAPACITORS

Ref.	Value		Type	D.C. Working Voltage	Tolerance ± %	Part No.	Description
	Mfd.	pf.					
C1	—	600	S.M.	350	10	AP19652	L.W. Aerial coupling fixed tuning.
C2	—	85	S.M.	350	2	AP19644 AP19645	L.W. Aerial grid fixed tuning.
C3	.05	—	P.T.	350	20	P12514	V1 and V2 Screen decoupling.
C4	—	100	S.C.	750	20	AP17336	V1 grid isolating capacitor.
C5	—	110	S.M.	350	2	AP17058 AP16304	1st I.F.T. Primary fixed tuning.
C6	.002	—	P.T.	500	25	P8995	P.U. Tone correction circuit.
C7	—	110	S.M.	350	2	AP17058 AP16304	1st I.F.T. Secondary fixed tuning.
C8	.001	—	P.T.	500	25	P3768	V1 Osc. anode isolating capacitor.
C9	—	56	S.C.	750	20	AP18162	V1 Osc. grid capacitor.
C10	—	33	S.M.	350	2	AP17919	L.W. Osc. fixed tuning.
C11	—	240	S.M.	350	2	AP19690 AP19648	L.W. Osc. fixed tuning.
C12	—	365	S.M.	350	1	AP19650 AP19651	L.W. Osc. padding capacitor.
C13	—	515	S.M.	350	1	AP17207 AP17175	M.W. Osc. padding capacitor.
C14	—	56	S.C.	750	20	AP18162	S.W. Osc. coupling isolating capacitor.
C15	.05	—	P.T.	350	20	P3770	A.V.C. decoupling capacitor.
C16	—	110	S.M.	350	2	AP17058 AP16304	2nd I.F.T. Primary fixed tuning.
C17	—	100	M.M.	350	20	P3775	Signal diode filter capacitor.
C18	—	110	S.M.	350	2	AP17058 AP16304	2nd I.F.T. Secondary fixed tuning.
C19	—	100	M.M.	350	20	P3775	Signal diode filter capacitor.
C20	.002	—	P.T.	500	25	P8995	Audio coupling capacitor to V3 grid.
C21	.005	—	P.T.	500	25	P3767	Fixed tone control capacitor.
C22	50	—	ELECT.	12	—	P12662	V3 Cathode bias coupling.
C23	32	—	"	350	—	AP19643	H.T. line smoothing. AC41 only
C24	32	—	"	350	—		
C25	.05	—	P.T.	350	20	P12514	Part of variable tone control. AC41 only
The following capacitors C23–C30 are used only in Model DAC41.							
C23	50	—	ELECT.	350	—	AP17168	H.T. line smoothing. H.T. line reservoir.
C24	50	—	"	350	—		
C25	.001	—	P.T.	1,000	25	AP18629	Aerial isolating capacitor.
C26	.01	—	P.T.	1,000	25	AP17939	True earth isolating capacitor.
C27	.005	—	P.T.	750	25	AP19727	P.U. Tone correction circuit.
C28	.01	—	P.T.	750	25	AP19745	P.U. Isolating capacitor.
C29	.01	—	P.T.	750	25	AP19745	H.F. Filter capacitor.
C30	.05	—	P.T.	350	20	P3770	Part of variable tone control.
TC1	—	60–120	Trimmer	—	—	AP19637	S.W. Aerial trimmer. M.W. Aerial trimmer.
TC2	—	4–40	"	—	—		
TC3	—	60–120	"	—	—	AP19637	S.W. Osc. trimmer. M.W. Osc. trimmer.
TC4	—	4–40	"	—	—		
VC1	—	528	Ganged	—	—	BP17863	Aerial circuit tuning. Oscillator circuit tuning.
VC2	—	528					

S.M. = Silvered Mica. P.T. = Paper Tubular. M.M. = Moulded Mica. S.C. = Silvered Ceramic.

RESISTORS

Reference	Value in Ohms	Rating in Watts	Tolerance ± %	Part No.	Description
R1	39,000	$\frac{1}{2}$	10	P6760	V1 and V2 Screen decoupling. AC41 only
R2	680,000	$\frac{1}{2}$	20	P7073	V1 Grid A.V.C. feed resistor.
R3	680,000	$\frac{1}{2}$	20	P7073	V1 Osc. section grid return on P.U.
R4	330	$\frac{1}{2}$	20	P6233	C1 Cathode bias.
R5	47,000	$\frac{1}{2}$	20	P6779	V1 Osc. grid leak.
R6	22,000	1	10	P6699	V1 Osc. anode load. AC41 only
R7	100	$\frac{1}{2}$	20	P6107	V1 Osc. Stabiliser on S.W.
R8	1.5 Meg.	$\frac{1}{2}$	20	P7157	A.V.C. decoupling.
R9	47,000	$\frac{1}{2}$	20	P6779	Signal diode filter.
R10	680,000	$\frac{1}{2}$	20	P7073	Part of A.V.C. feed to delay diode.
R11	20 Meg.	$\frac{1}{2}$	33 $\frac{1}{2}$	P14545	Part of A.V.C. delay voltage Pot.
R12	330,000	$\frac{1}{2}$	20	P6989	Signal diode load.
R13	47,000	$\frac{1}{2}$	20	P6779	V3 Grid Stabiliser.
R14	180	$\frac{1}{2}$	5	P6178	V3 Cathode bias.
R15	1,500	6	5	AP19642	H.T. line smoothing. AC41 only
The following Resistors R1, R6 and R15–R20 are used only in Model DAC41.					
R1	27,000	$\frac{1}{2}$	10	P6718	V1 and V2 Screen decoupling.
R6	10,000	$\frac{1}{2}$	20	P6610	V1 Osc. anode load.
R15	1,000	6	5	AP19726	H.T. line smoothing.
R16	1 Meg.	$\frac{1}{2}$	20	P7115	Aerial Static discharger.
R17	200 + 200 + 1,030	15	5	AP19725	Heater circuit ballast.
R18	250	4	20	AP18039	V4 Anode limiter.
R19	75	4	10	AP18192	Scale lamp shunt.
R20	2,200	$\frac{1}{2}$	20	P6443	V2 Grid Stabiliser.
VR1	0.5 Meg.	—	—	PB21619	Volume Control.
VR2	50,000	—	—	BP21620	Tone Control.

COILS, CHOKES & TRANSFORMERS

Reference	Resistance in Ohms	Part Number	Description
L1	0.5	BS19712	{ S.W. Aerial coupling. S.W. Aerial tuning.
L2	Less than 0.5		
L3	7.0	BS19710	{ M.W. Aerial tuning. L.W. Aerial coupling.
L4	50.0		
L5	20.0	BS19715	{ L.W. Aerial tuning. S.W. Oscillator tuning.
L6	Less than 0.5		
L7	0.5	BS17259	{ S.W. Oscillator coupling. M.W. Oscillator coupling.
L8	1.0		
L9	5.0	BS19714	{ M.W. Oscillator tuning. L.W. Oscillator tuning.
L10	5.0		
L11	3.0	AS16196	{ R.F. Filter Chokes (DAC41 only).
L12	3.0		
I.F.T.1	12.5 (P)	ES16447	{ Primary 1st I.F. Transformer. Secondary 1st I.F. Transformer.
	12.5 (S)		
I.F.T.2	12.5 (P)	ES16447	{ Primary 2nd I.F. Transformer. Secondary 2nd I.F. Transformer.
	12.5 (S)		
AUDIO OUTPUT TRANSFORMER			
T1	410.0 (P) Less than 0.5	AS19697	{ Primary inductance at 400 cycles. 5V. No load on Sec. is 5H. with 36 m/A. D.C. flowing. Ratio 47 : 1.
POWER TRANSFORMER			
T2	45.0 140.0 0.9 0.4	DS19700	{ Total Primary. H.T. Secondary. Rectifier Heater Secondary. V1 to V3 Heater Secondary. } AC41 only.

Iron Dust Core for Coils L1-L10 : AP17109.

VALVE VOLTAGES

Input 230 volts A.C., 50 cycles. Receiver set to M.W. with no signal input. All measurements taken on an Avometer Model 7, with chassis negative ; 1,000-volt range for H.T. and 10 volt (or appropriate range) for cathode measurements.

Valve Type	Electrode	Pin No.	Voltage		Current mA.	
			AC41	DAC41	AC41	DAC41
V1	Hexode Anode	2	230	140	2.0	1.5
ECH42	Osc. Anode	3	120	100	5.0	3.8
UCH42	Screen	5	60	50	3.0	2.1
	Cathode	7	*3.3	*2.5	10.0	7.5
V2	Anode	6	230	140	—	—
EBF80	Screen	1	60	50	—	—
	Cathode	3	—	—	4.0	4.6
V3	Anode	2	220	130	32.0	36.0
EL41	Screen	5	230	140	5.0	7.0
	Cathode	3 & 7	6.8	7.7	37.0	43.0
V4	Anode	2 & 6	300 A.C.	210 A.C.	—	—
EZ40	Cathode	7	—	—	53.0	55.0
UY41						

* These voltages apply only when the receiver is switched to the "gram" position.

DISMANTLING PROCEDURE

Set the tuning control so that the pointers are approximately in the mid-position on the tuning scale, then lift the pointer drivers off their respective carriages. Unsolder the speaker connection to the output transformer and unscrew the pilot lamp holders from the rear of the scale reflector plate. Remove the four control knobs from the front of the receiver and unscrew the four 4BA bolts securing the chassis to the cabinet. Finally, withdraw chassis from cabinet.

SPEAKER

High Flux Ellipticle P.M., Part No. BP17385

GRAMOPHONE PICK-UP

The waverange switch should be set to the "gram" position when the receiver is being used for record reproduction. A good quality pick-up with an adequate output should be used, preferably of the "crystal" type. A "Screened" lead having the minimum possible length should be used for the pick-up connections. The inner conductor is connected to the top socket, whilst the screening, forming the outer conductor, is connected to the lower socket.

An input of approximately 150 m/volts R.M.S. (AC41) and 450 m/volts R.M.S. (DAC41) is required to produce a standard output of 50 m/watts. Input Impedance = approximately 0.5 megohms.

AC.41 CIRCUIT DIAGRAM

www.radio-workshop.co.uk

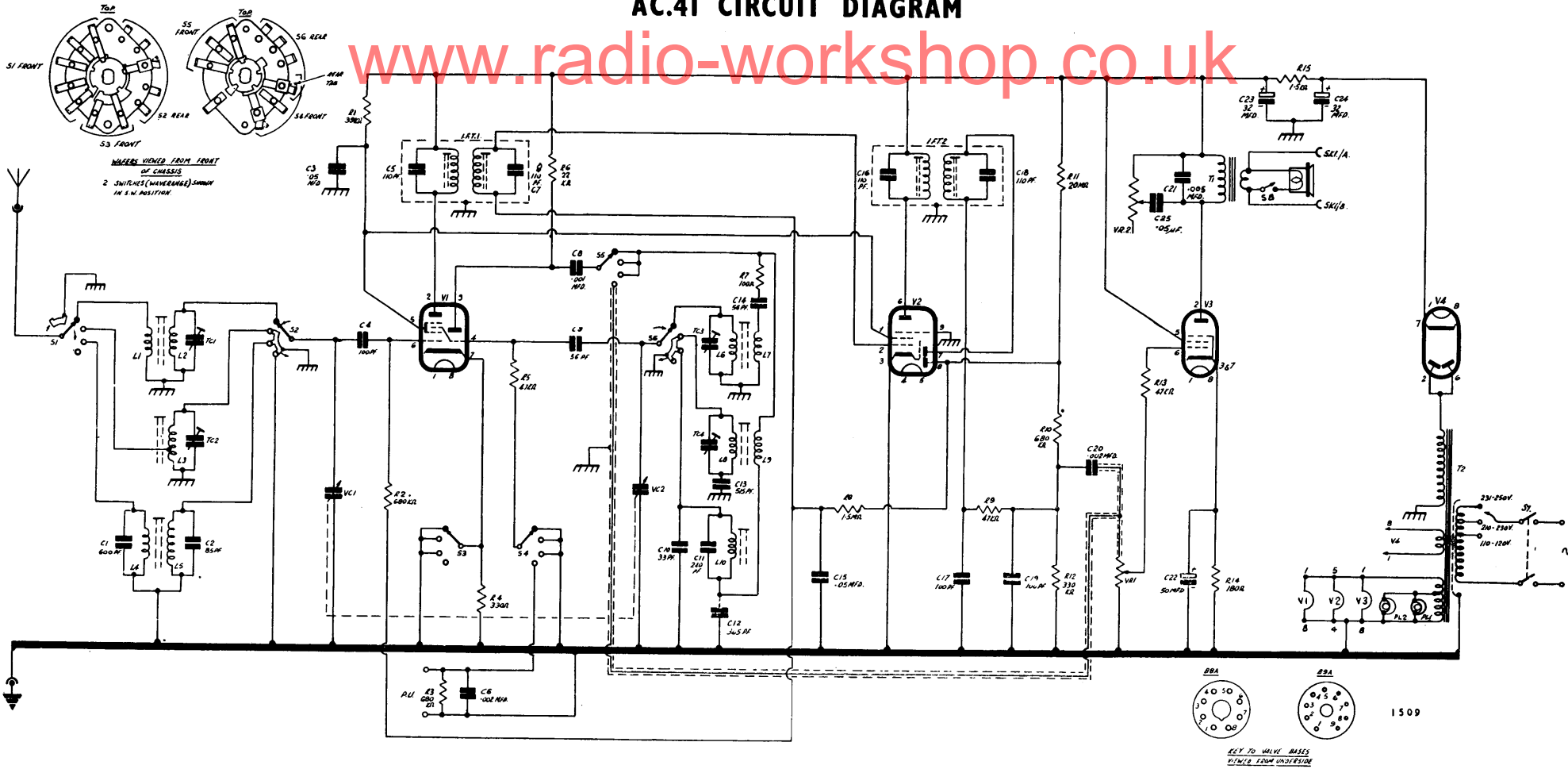

DAC.41 CIRCUIT DIAGRAM

www.radio-workshop.co.uk

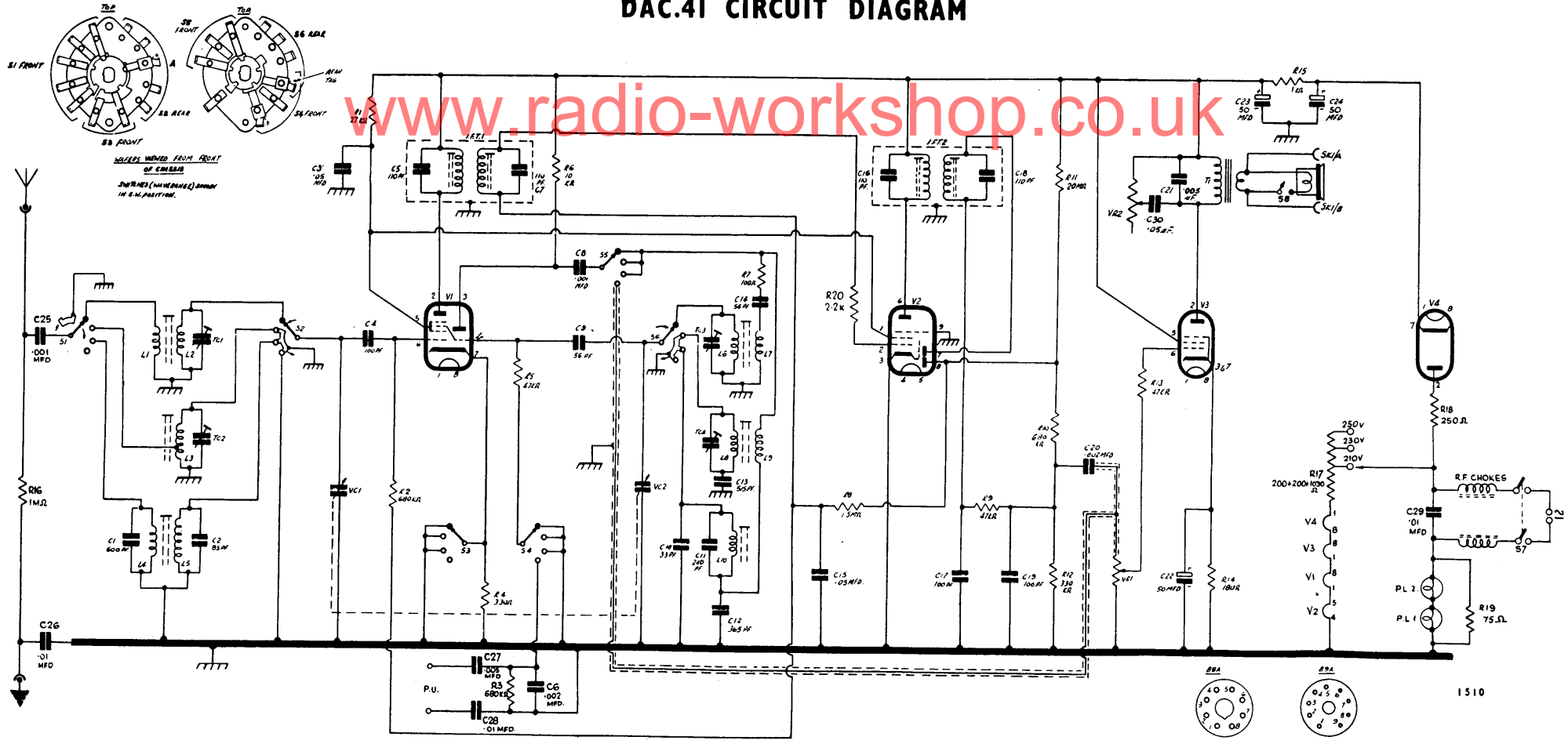

Page 5

1510

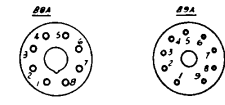

AC/DAC41

www.radio-workshop.co.uk

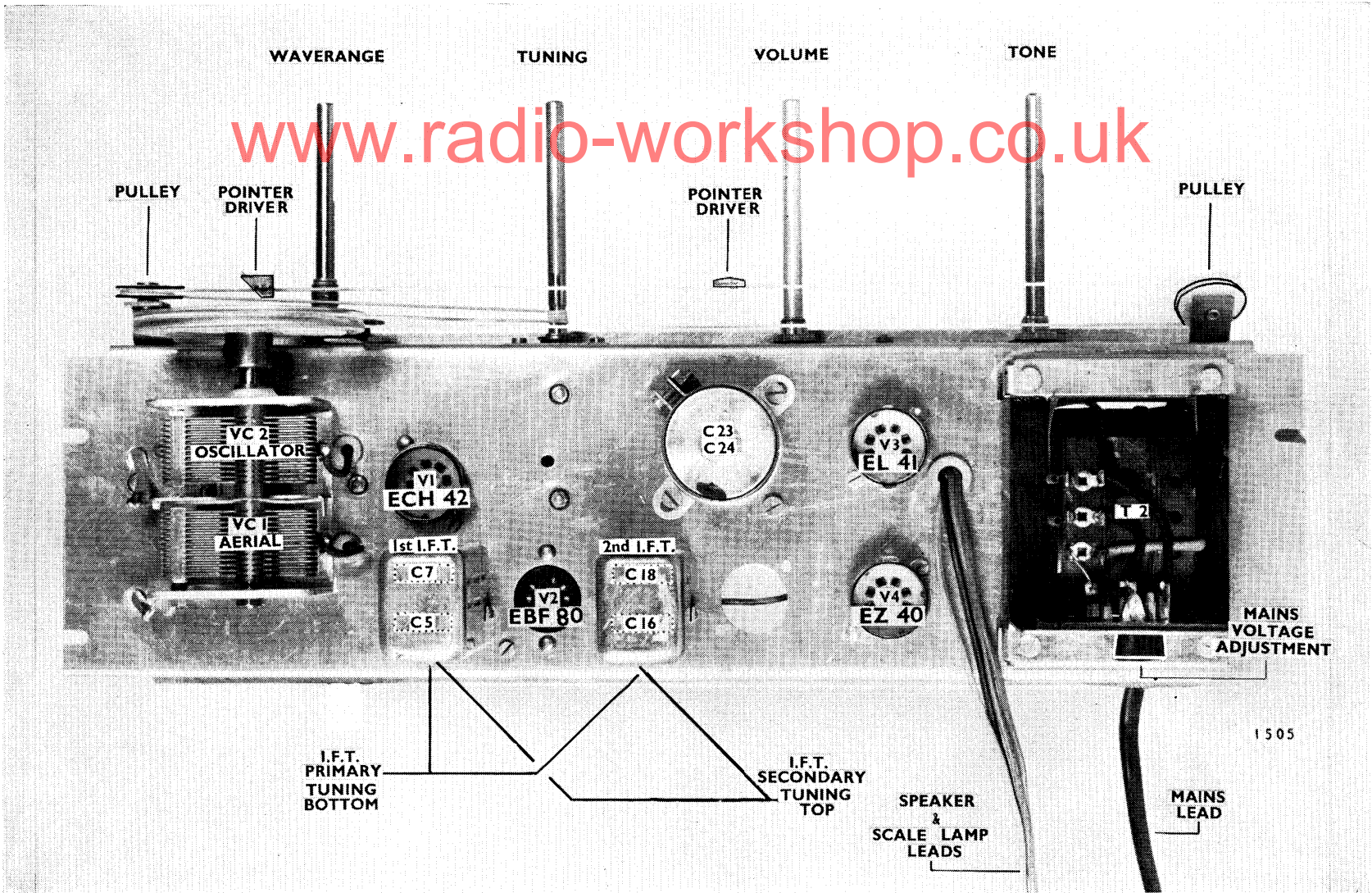
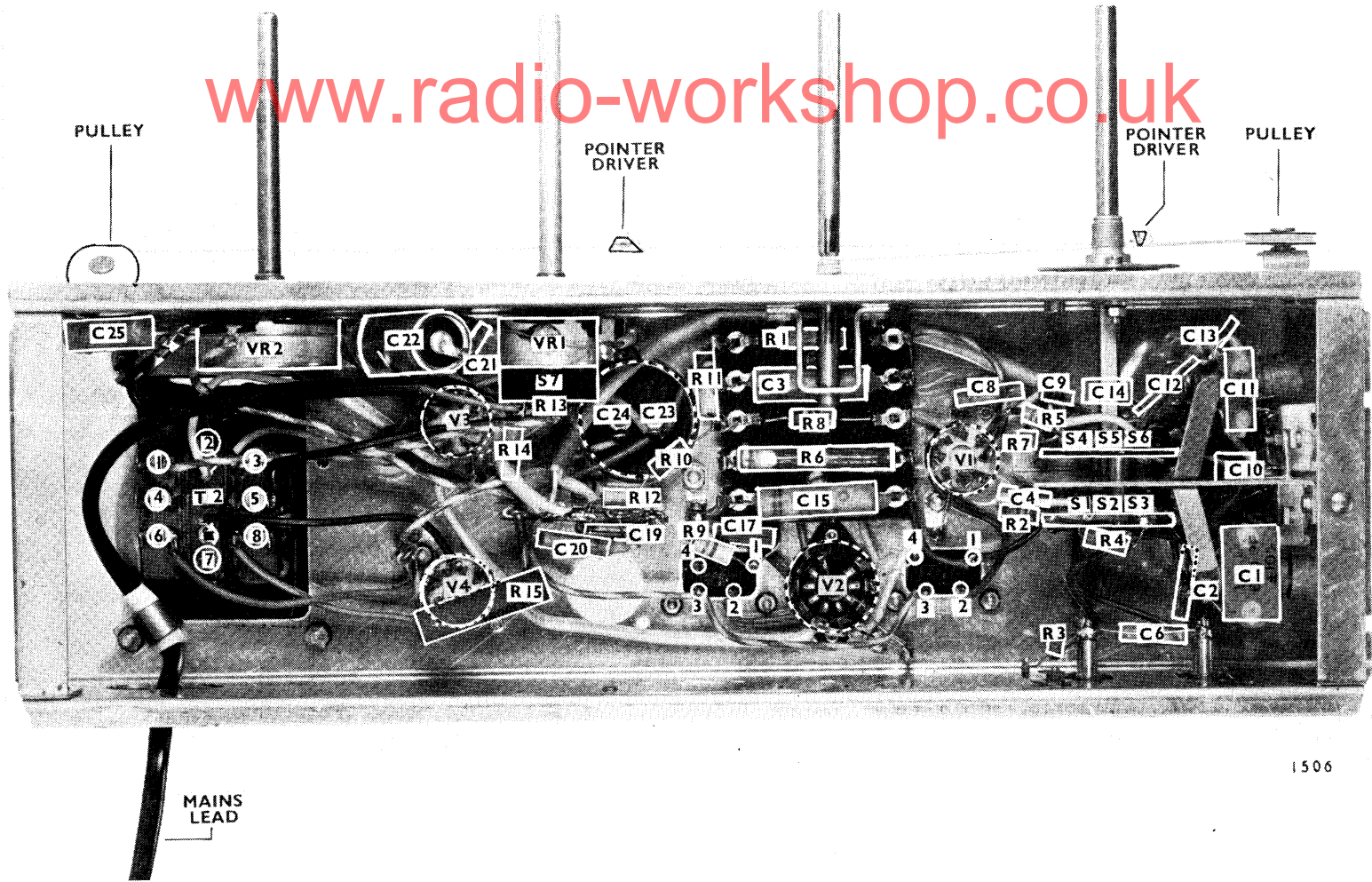

PLATE 1

TOP VIEW OF AC41

TONE VOLUME TUNING WAVERANGE

www.radio-workshop.co.uk



Page 7

1506

PLATE II

UNDER VIEW OF AC41

AC/DAC41

ALIGNMENT PROCEDURE

TEST EQUIPMENT REQUIRED

Signal Generator (for R.F. and I.F. Alignment).
 Frequency Range : 150 Kc/s to 21 Mc/s.
 Calibration Accuracy : $\pm 1\%$.
 Modulation : 400 cycles at 30%.
 Output Wattmeter : 50 to 1,000 milliwatts.
 Standard Dummy Aerial, comprising a 200 pfd. capacitor for L.W. and M.W., and a 400-ohm non-inductive resistor for the S.W. band.

PRELIMINARY

The receiver and signal generator should be switched on 10 minutes before commencing alignment. Use the lowest input from the signal generator consistent with a reasonable output and with the volume control at maximum. Check the position of the pointer in relation to the tuning condenser. With the plates fully meshed, the pointer should

coincide with the DATUM line as printed on the auxiliary calibration scale. When aligning the R.F. Section of the receiver, the signal generator should be connected to the aerial socket. On I.F. alignment, an isolating capacitor of .01 mfd. will be required to ensure that the A.V.C. line is not short-circuited ; it should be connected in series with the Signal generator output lead.

I.F. ALIGNMENT (470 Kc/s)

Set the tuning condenser until it is one-third open, corresponding to approximately 1,000 Kc/s. Switch to M.W. and connect the Signal generator to pin 2 of V2. Tune the Secondary and Primary of the 2nd I.F.T. in the order given, for maximum output. Transfer the Signal generator output to pin 6 of V1. Tune the Secondary and Primary of the 1st I.F.T. in the order given, decreasing the Signal generator output as the circuits approach resonance. Peak each circuit once only.

www.radio-workshop.co.uk

R.F. ALIGNMENT

Operation	Waverange	Signal Generator Frequency	Receiver Calibration Mark	Adjust
1	L.W.	214 Kc/s	1,400 m.	Cores of L10 Osc., and L4-5 Aerial, for max. output.
2	—	—	—	Check Calibration.
3	M.W.	600 Kc/s	500 m.	Cores of L8-9 Osc., and L3 Aerial, for max. output.
4	M.W.	1,500 Kc/s	200 m.	Trimmers TC4 Osc., and TC2 Aerial, for max. output.
5	Repeat Operations 3 & 4			Check Calibration.
6	S.W.	10 Mc/s	30 m.	Cores of L6-7 Osc., and L1-2 Aerial, for max. output.
7	S.W.	20 Mc/s	15 m.	Trimmers TC3 Osc., and TC1 Aerial, for max. output.
8	Repeat Operations 6 & 7			Check Calibration.

NOTE.—Re-alignment of the receiver must be carried out in the order given above. An auxiliary calibration scale is attached to the rear of the drive drum and should be used for calibrating the receiver when it is removed from the cabinet.

COIL & TRIMMER LOCATION
 END VIEW

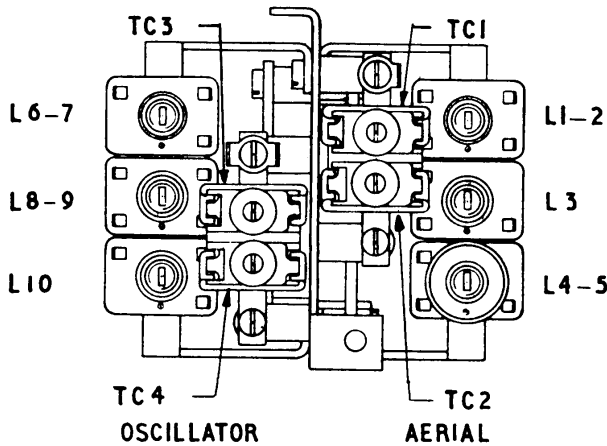

1507

CONNECTIONS TO I.F. TRANSFORMERS

The external connections to the I.F. transformers are made to tags situated on the base of the I.F. transformer. The tag numbers are shown on plate 2. The connections are as follows:—

1st I.F.T.	Tag No. 1.	To R8, R2, C15 and S1, 2, 3, tag No. 8.
Part No. ES16447	Tag No. 2.	To pin 2 of V1.
	Tag No. 3.	To H.T. +
	Tag No. 4.	To pin 2 of V2.
	2nd I.F.T.	Tag No. 1.
Part No. ES16447	Tag No. 2.	To pin 6 of V2.
	Tag No. 3.	To H.T. +
	Tag No. 4.	To pin 7 of V2.

CONNECTIONS TO MAINS TRANSFORMER

The external connections to the mains transformer are made to tags situated on the base of the transformer. These tag numbers are shown on plate 2. The connections are as follows:—

Part No. DS19700	Tag No. 1.	To Chassis.
	Tag No. 2.	To pin 1 of V3.
	Tag No. 3.	To pilot lamp holder.
	Tag No. 4.	To On/Off Switch S7.
	Tag No. 5.	To On/Off Switch S7.
	Tag No. 6.	To pin 8 of V4.
	Tag No. 7.	To pin 1 of V4.
	Tag No. 8.	To pin 6 of V4.

FITTING CORD DRIVE

With the plates of the tuning condenser fully meshed, the drive drum should be set so that the auxiliary pointer coincides with the DATUM line on the scale attached to the rear of the drive drum. The length of the cord after clenching in the anchor, is 43 inches. Hook the cord and anchor to the drive tension spring and attach the opposite end of the spring to the drive drum. Pass the cord through the opening on the edge of the drive drum and over pulley No. 1. Continue by passing the cord over pulley No. 2, and then take three turns around the tuning spindle in a clockwise direction. Finally, pass the cord around the drive drum, through the opening on the edge of the drive drum, and attach to the opposite end of the anchor. Having fitted the cord drive, clip the pointer drivers to the cord, but do not clench. Replace the chassis in the cabinet, set the pointers to their respective DATUM lines to be found on the right-hand edge of both the M.W. and L.W./S.W. tuning scales, then drop each pointer driver into its pointer carriage and clench clips tightly on pointer drivers.

PART NUMBERS

Cord Drive (including cord drive, clip and tension spring)	ES21612
Drive Drum	AP16287
Pointer	AP21603
Pointer Carriage	AP16329
Pointer Driver	AP16296
Pulley (Rivet Pulley AP16029)	P12416
Tension Spring	P1941

WARNING

When servicing the DAC41 Receiver, remember that one side of the electricity supply is connected to the chassis, and may, under certain conditions, be "live". Do not, therefore, connect any earthed equipment or a direct earth to the chassis without first isolating it by a fixed capacitor of approximately .005 mfd. Care should be taken in handling the chassis.

PART NUMBERS

The following part numbers are not shown elsewhere in these Service Instructions. When ordering replacements, please quote:—

1. Type and serial number of receiver.
2. Part number and description of item.
3. Quantity required.

COMMON PART NUMBERS

Cabinet	AP22733
Coil Deck (complete, less switch operating bar)	ES19708
Coil Deck (Aerial section)	BS19849
Coil Deck (Osc. section)	BS19850
Label Calibration	AP19629
Tuning Scale	DP21609
Valveholder Noval B9A	P3938
Valveholder B8A	AP17088 or AP17391

AC41 PART NUMBERS

Cabinet Back	EP21645
Knob "Tone"	AP20677
"Volume and On/Off"	AP20674
"Tuning"	AP20675
"Waveband"	AP20857
"Skirt" (one used on each knob)	AP21690
"Clip" (one used on each knob)	AP16423

DAC41 PART NUMBERS

Cabinet Back	BS21610
Knob "Tone"	AP20696
"Volume and On/Off"	AP20695
"Tuning"	AP20694
"Waveband"	AP20928
Grub Screw (one used on each knob)	P8516

MODIFICATIONS

PART NUMBERS

AC/DAC41: Cabinet was Part No. EP21564, is now AP22733. CN.4748.
 AC/DAC41: 2nd I.F.T. was Part No. ES16448, is now ES16447. CN.4788.

DAC41 only: Cabinet Back was Part No. EP21610, is now BS21610. CN.4565.
 DAC41 only: Volume Control VR1 was Part No. CP19636, is now BP21619. CN.4759.

SKETCH OF DRIVE CORD

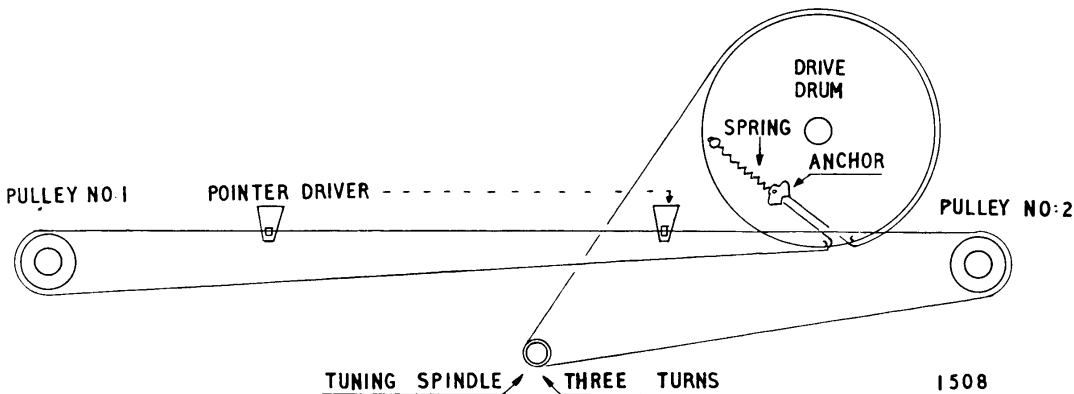

COIL DECK CONNECTIONS

To remove the coil deck from the chassis, turn the wave-range switch to the "gram" position and unscrew the switch locating plate from the chassis. Withdraw switch operating bar from the coil deck. Next remove the four 6BA nuts and bolts securing the coil deck to the chassis and unsolder the following wires.

AERIAL SECTION

1. Remove lead and capacitor connecting switch S1, 2, 3, tag No. 6, to VC1 Stator and C4.
2. Remove lead connecting switch S1, 2, 3, tag No. 7, to aerial input socket.
3. Remove R2 and lead from 1st I.F.T. pin No. 1 from tag No. 8, switch S1, 2, 3.
4. Remove lead connecting switch S1, 2, 3, tag No. 12, to pin 7 of V1.
5. Remove screened lead connecting L1/2 contact No. 1 and 2 to frame of VC1.

OSCILLATOR SECTION

1. Remove screened lead connecting switch S4, 5, 6, tag No. 3, to tag panel on centre of chassis (i.e. C20 and VR1).
2. Remove C8, connecting switch S4, 5, 6, tag No. 4 and pin No. 3 of V1.
3. Remove lead connecting switch S4, 5, 6, tag No. 5, to VC2 Stator at capacitor end. Also C9 from pin No. 4 of V1.
4. Remove lead connecting pick-up input socket and switch S4, 5, 6, tag No. 9.
5. Remove EARTHING braid connecting Osc. deck to VC2 frame.

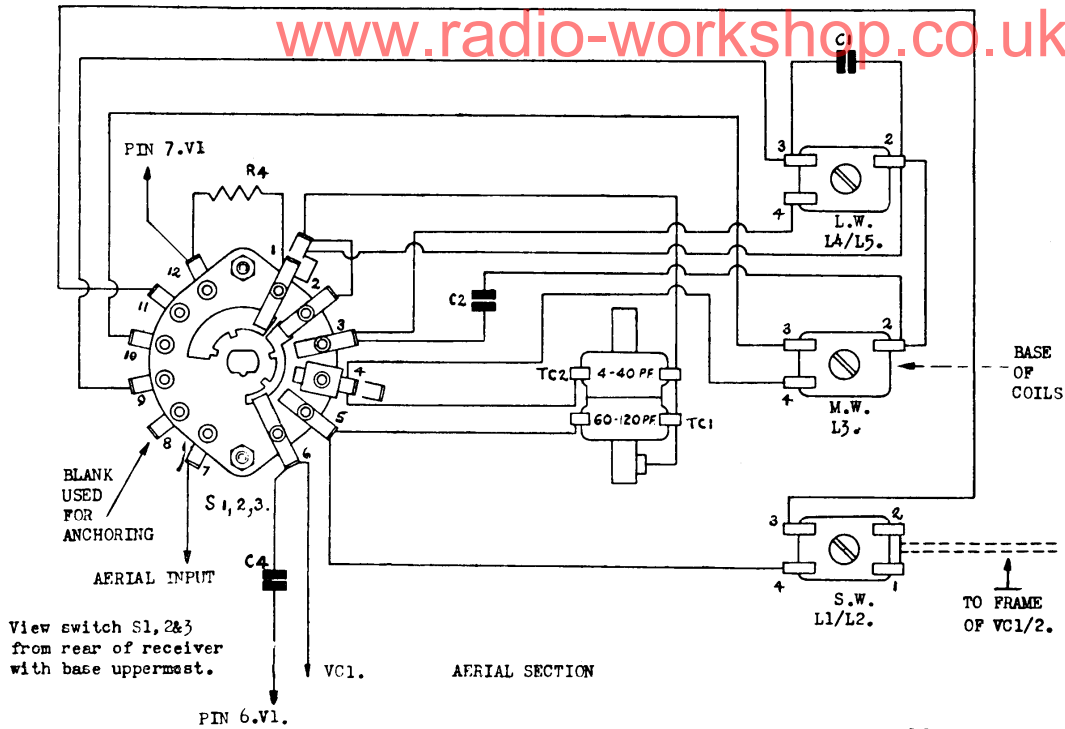

1296

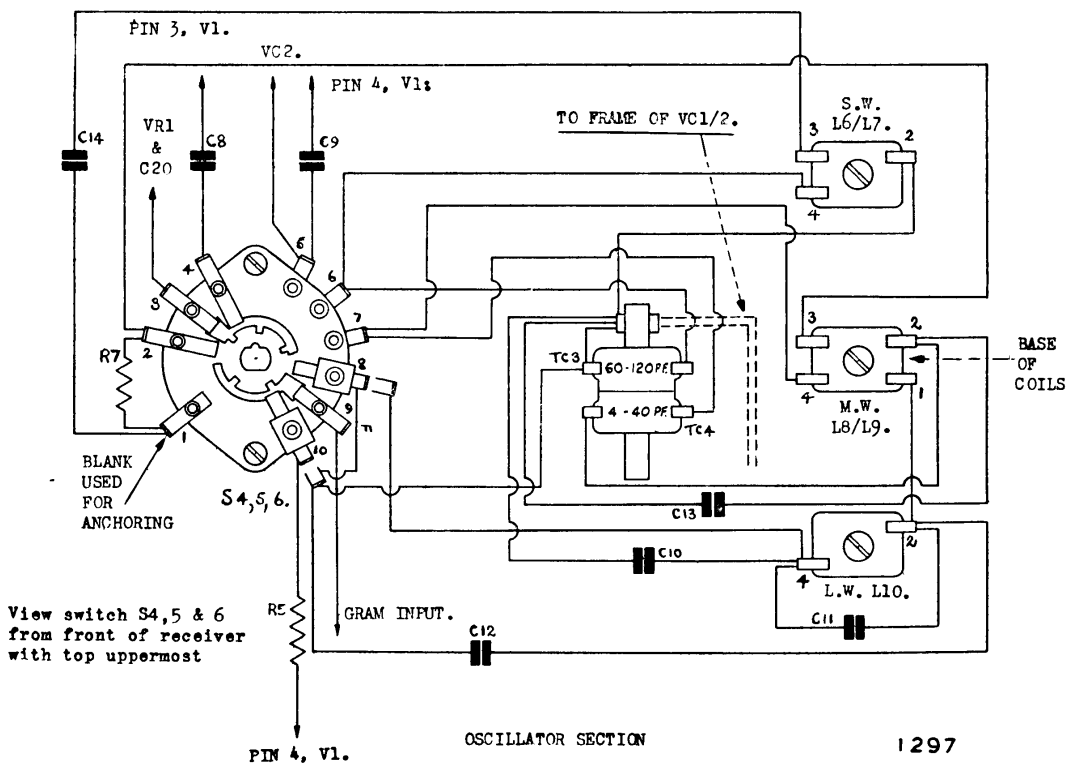

1297