

CIRCUIT DIAGRAM—DANSETTE MODEL 14-2
AMPLIFIER

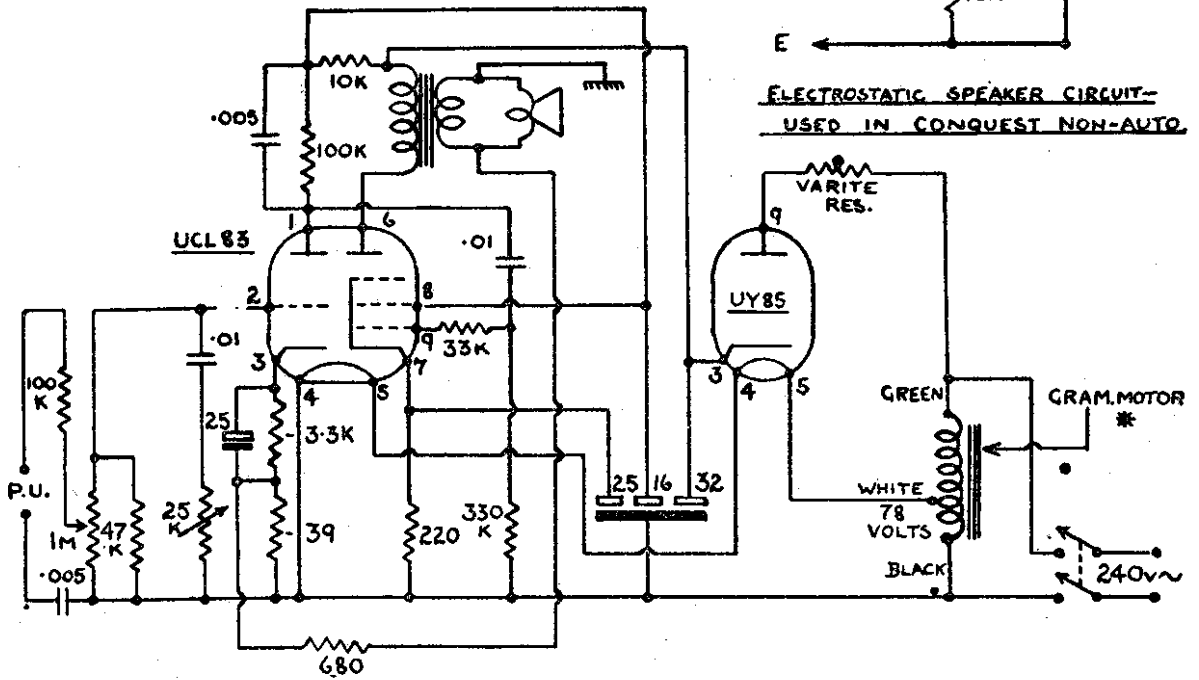

ELECTROSTATIC SPEAKER CIRCUIT—
USED IN CONQUEST NON-AUTO

* AUTO-TRANSFORMER USED IN EXPORT MODELS ONLY.

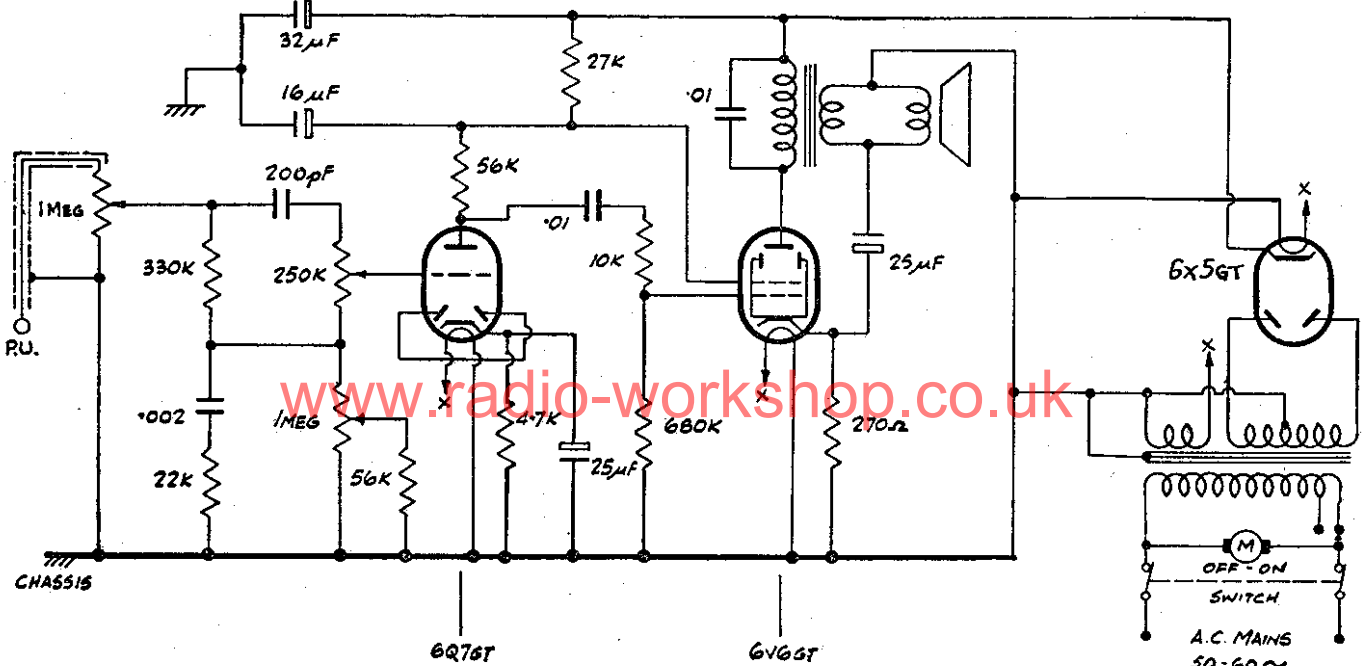

Above: DANSETTE
G32-SERIES

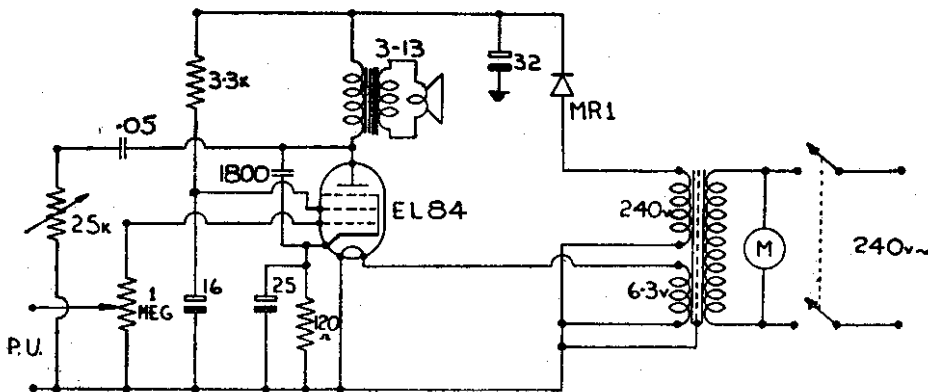

Left: DANSETTE MODEL
14-3 AMPLIFIER FOR
MAJOR DE LUXE

DIPLOMAT

General Description: Battery record player using a three-transistor amplifier, operated from 9-volt battery (Ever Ready PP10 or equivalent). Replacement styli Type GP65

Transistors: (TR1) OC78D or GET114; (TR2, 3) Matched OC78 or GET114. Later models: (TR1) OC81D; (TR2, 3) OC81.

Classic Record Reproducer: Transistor two-speed record reproducer with diamond stylus. Powered by six 1.5-volt U2 cells. Amplifier circuit is similar to that for "Diplomat".

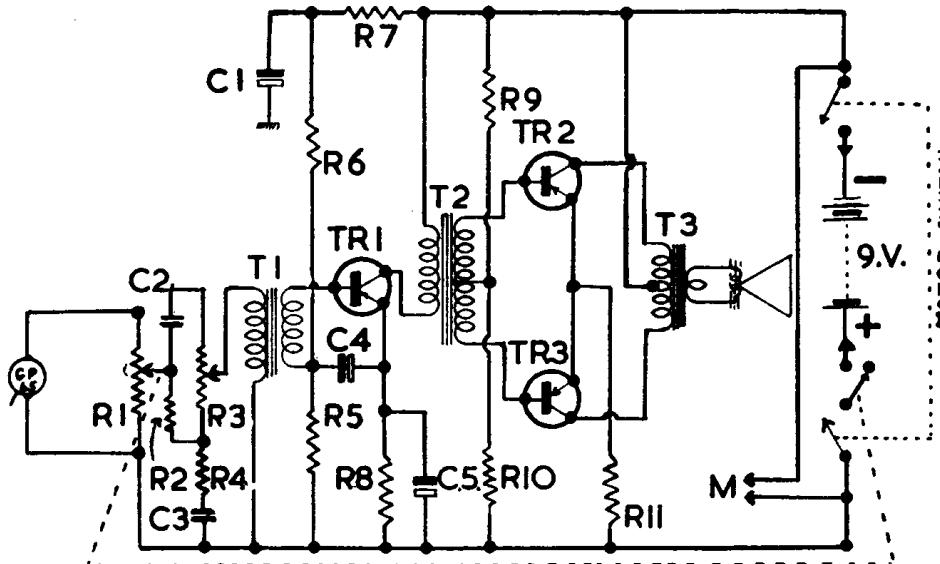

- Capacitors.**
 C1 100
 C2 200 pF.
 C3 2000 pF.
 C4 100 (6 v.)
 C5 100

- Resistors.**
 R1 1M
 R2 330k
 R3 250k
 R4 22k
 R5 12k
 R6 39k
 R7 680
 R8 560
 R9 4.7k
 R10 100
 R11 4.7 (5%)

CIRCUIT DIAGRAM—DANSETTE "DIPLOMAT"

Popular Record Reproducer: Two-valve (including rectifier), record reproducer with B.S.R. non-auto record unit. Valves (V1) UL84; (V2) UY85. A.C. mains 200-250 volts.

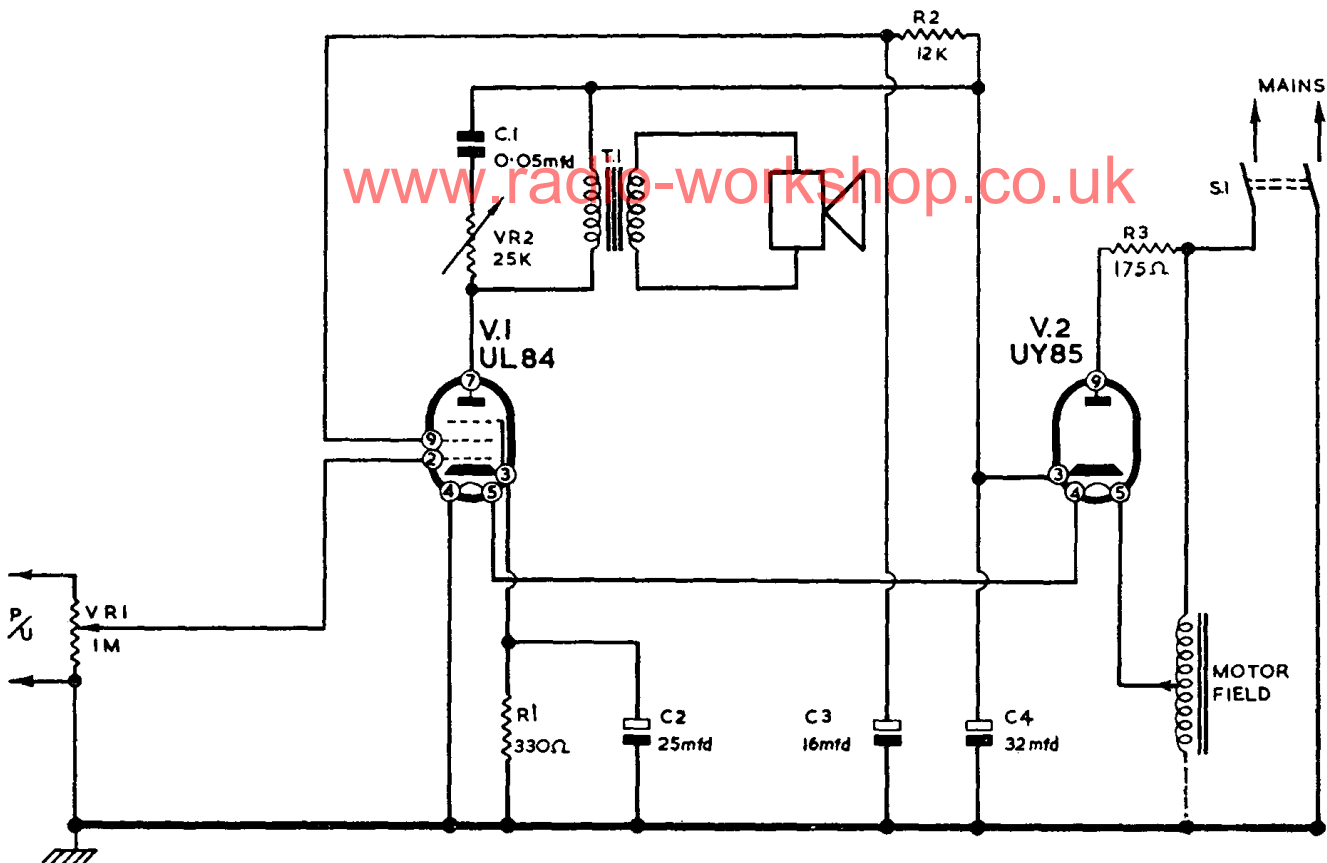

CIRCUIT DIAGRAM—DANSETTE "POPULAR" RECORD REPRODUCER

DANSETTE RECORD PLAYER "MONARCH"

General Description: Two-stage, single-valve amplifier with B.S.R. Monarch, type UA16 record changer and TC8M cartridge. Two elliptical 8 by 5-in. speakers in parallel. A.C. mains, 210-250 volts, 50 c/s. 42 watts (dual voltage model for use on 120-volt supplies has modified mains transformer).

Valve: (V1) ECL82. Metal rectifier, Westinghouse FC116.

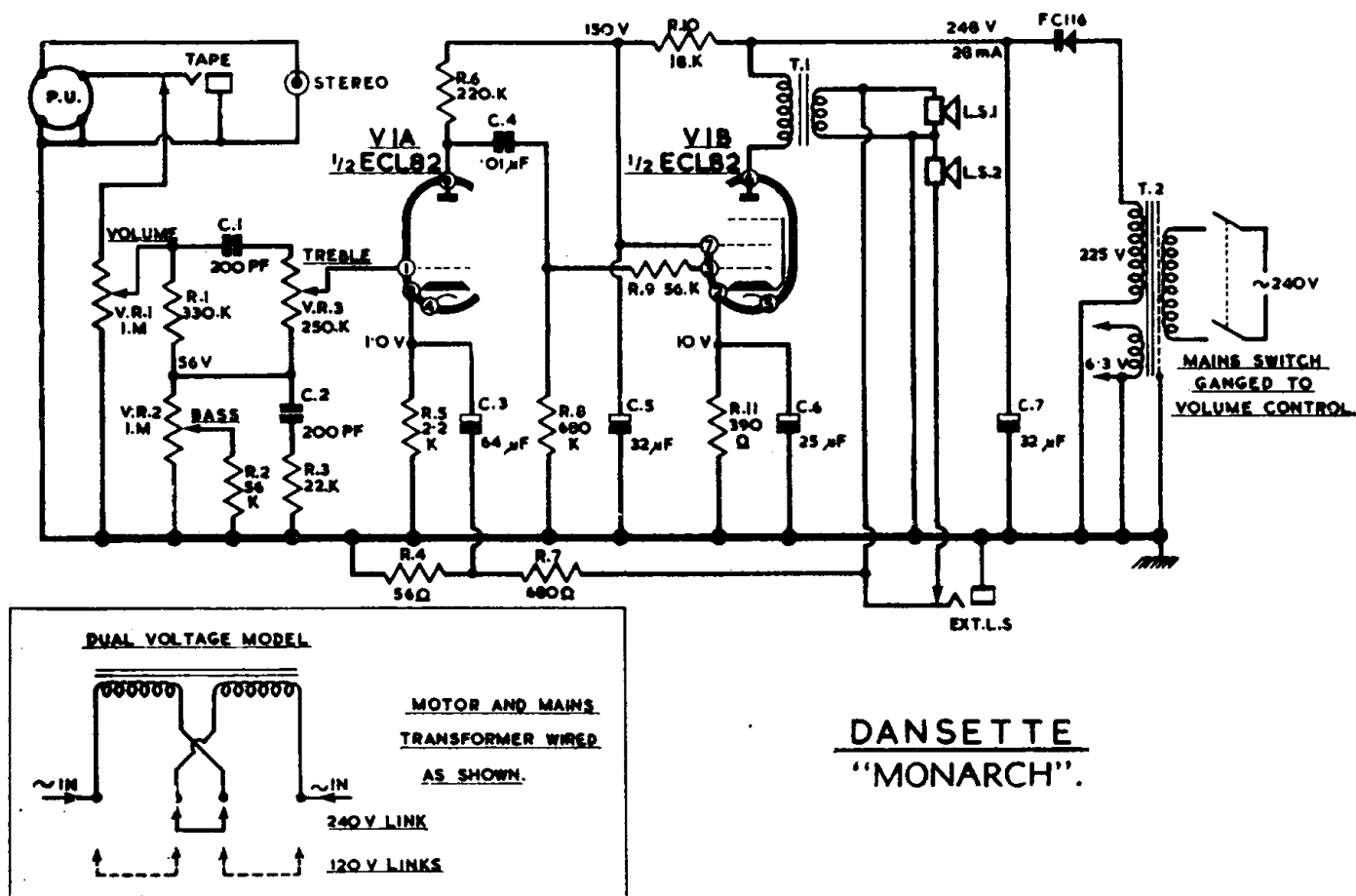

CIRCUIT DIAGRAM - DANSETTE "MONARCH" RECORD PLAYER

General Description: Mains only version employs two valves which give 2 watts output. B.S.R. UA50 Mini-changer with X1H cartridge. Speaker, elliptical 3 ohms. 210-250 A.C. mains only. Battery/Mains version employs four transistors and one diode which give a 1-watt output. B.S.R. Mini-changer with X1M cartridge. Speaker, elliptical 3 ohms. Six Ever-Ready HP2 batteries.

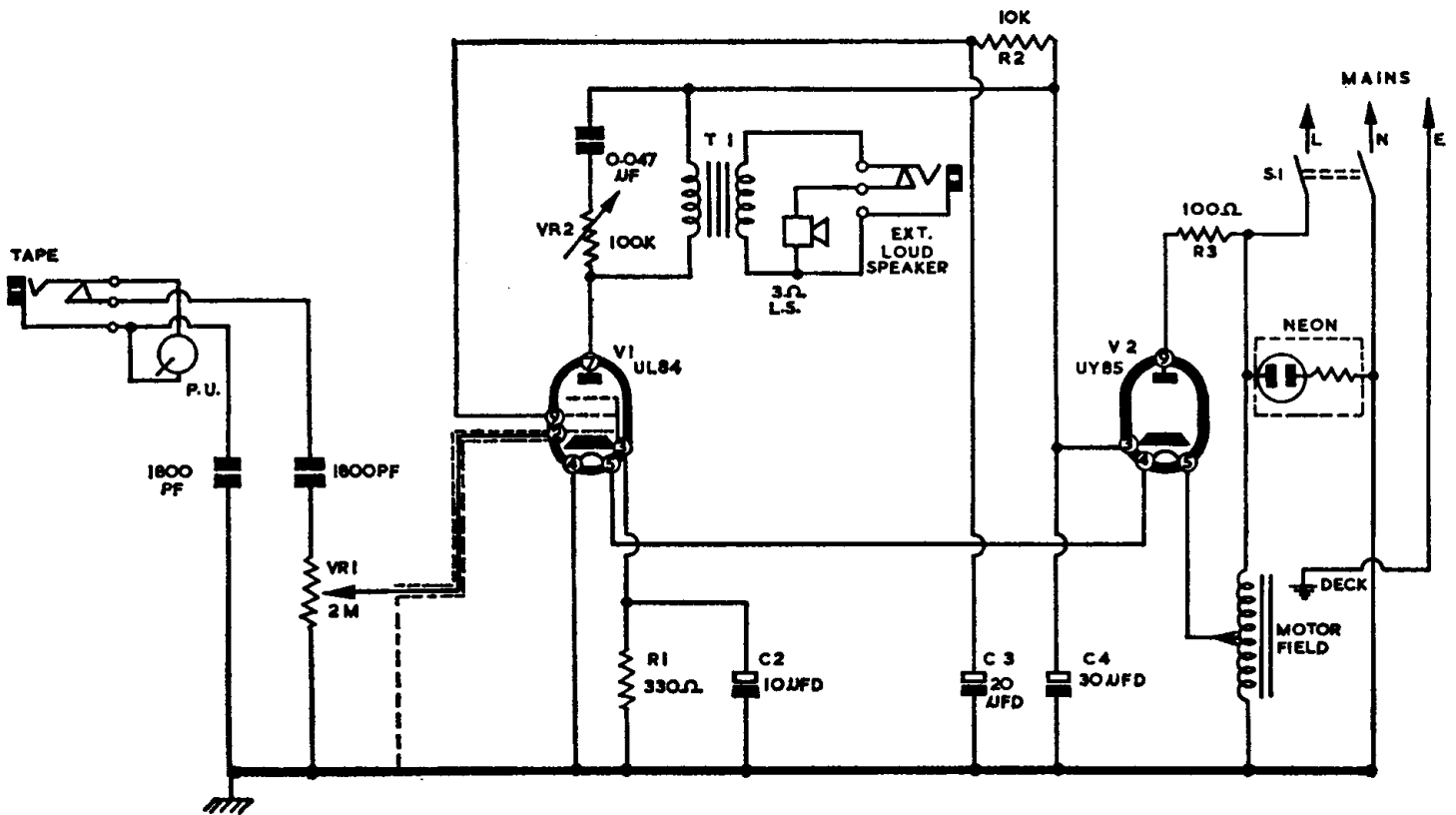

DANSETTE TRANSIT—MAINS ONLY VERSION

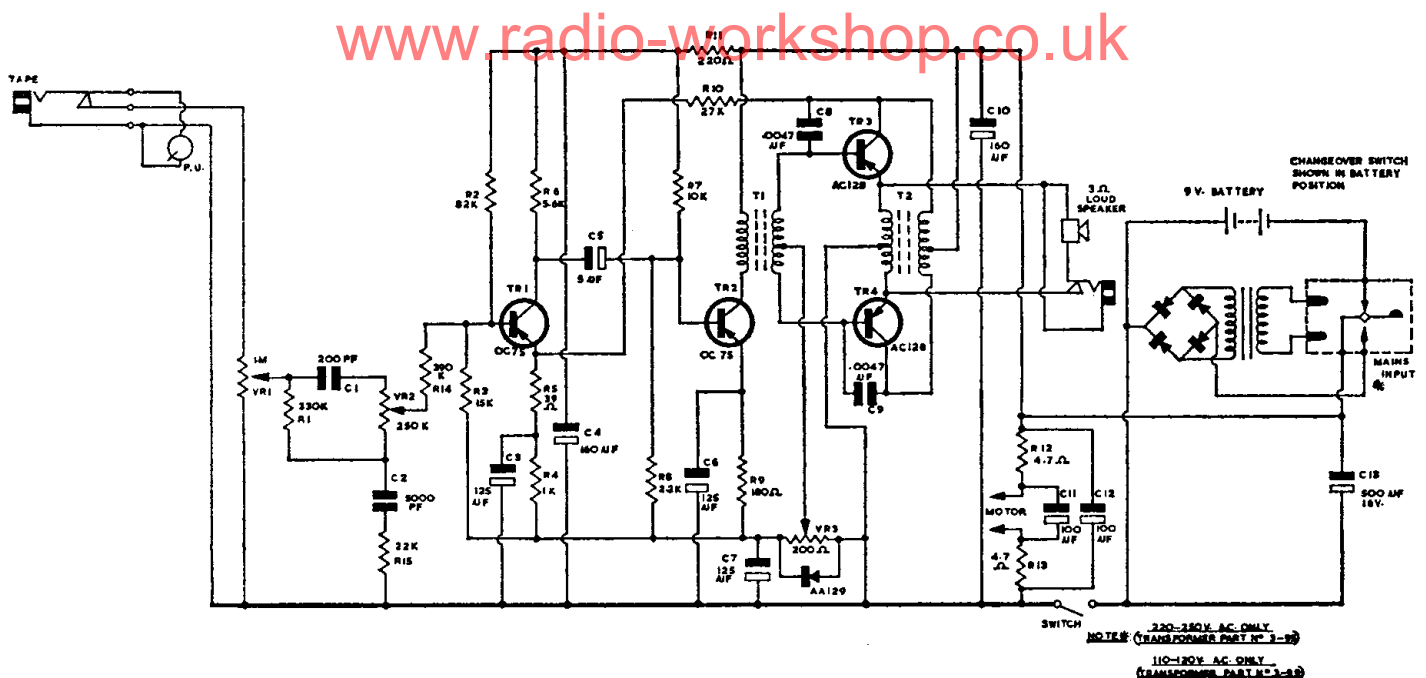

DANSETTE TRANSIT—BATTERY/MAINS VERSION

NOTE: 230-250V AC ONLY
(TRANSFORMER PART NO 3-12)
110-120V AC ONLY
(TRANSFORMER PART NO 3-13)

Dansette "Viva": Single-stage, two-valve (including rectifier) record reproducer for operation from A.C. mains, 200–250 volts, 50 c/s. (mains connected chassis). B.S.R. record unit with "Ful-fi" cartridge and TC8 stylus. To replace stylus: slacken screw at rear of stylus (one turn only). Ease out stylus in forward direction. Fit new stylus and when tightening fixing screw ensure that stylus is correctly seated and that head is positioned centrally on stylus coupler. Care should be taken as undue pressure exerted on stylus tip may result in damage.

Dansette "Imperial": Three-stage, two-valve record reproducer with push-pull output stage for operation on A.C. mains, 210–250 volts, 50 c/s., 45 watts. B.S.R. type auto record changer with TC8M cartridge. Valves two ECL86 with full-wave bridge metal rectifier. V1A is D.C. coupled to concertina phase-splitter with output stage operated in ultra-linear mode, providing 8 watts output over frequency range 30 c/s. to 15 kc/s. Passive treble and bass tone control networks. Sockets for external speaker, tape recorder, "Singalong" unit, and matching stereo amplifier unit. Weight 32 lb.

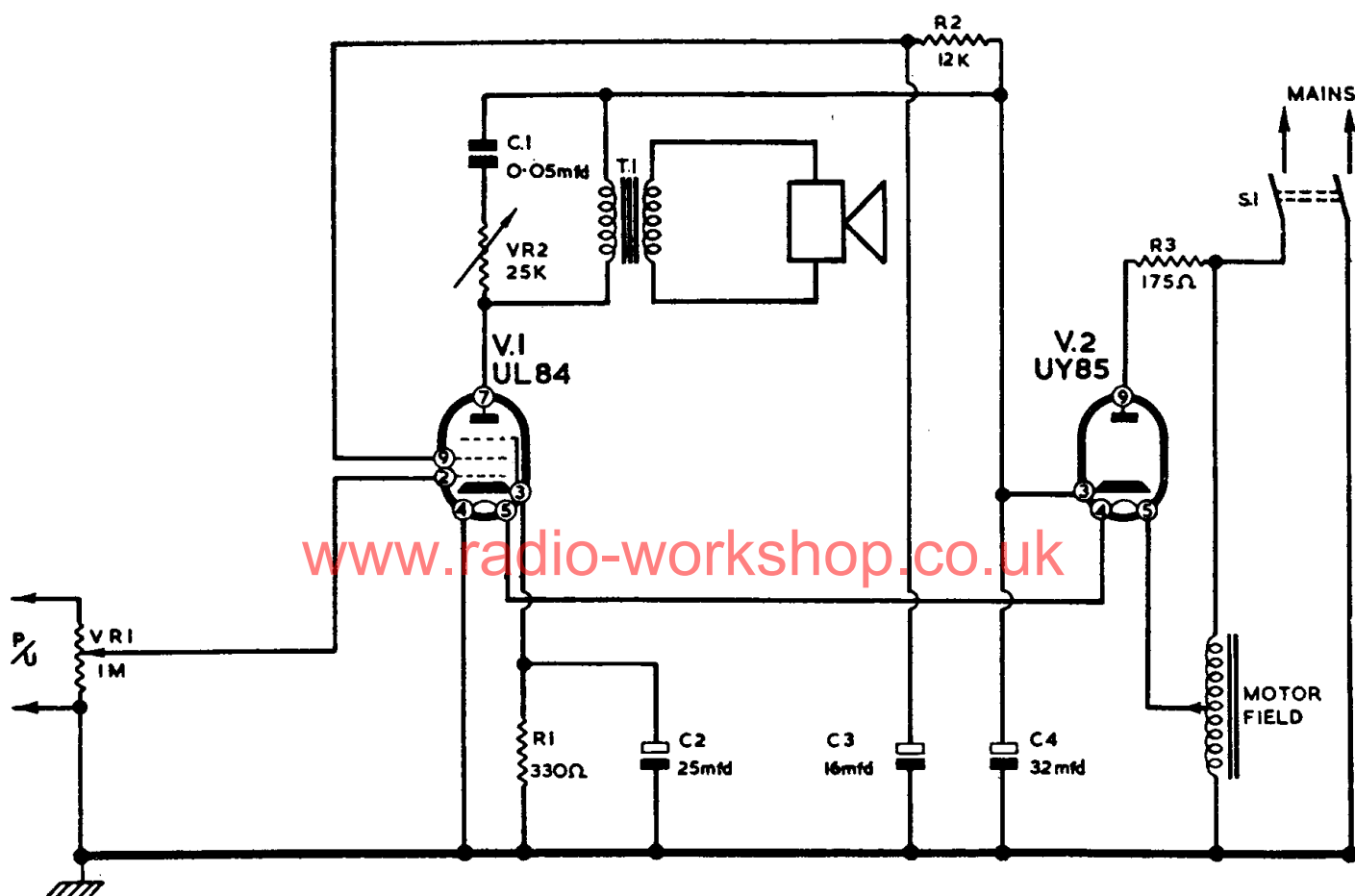

CIRCUIT DIAGRAM—DANSETTE "VIVA" RECORD REPRODUCER

DANSETTE "IMPERIAL"

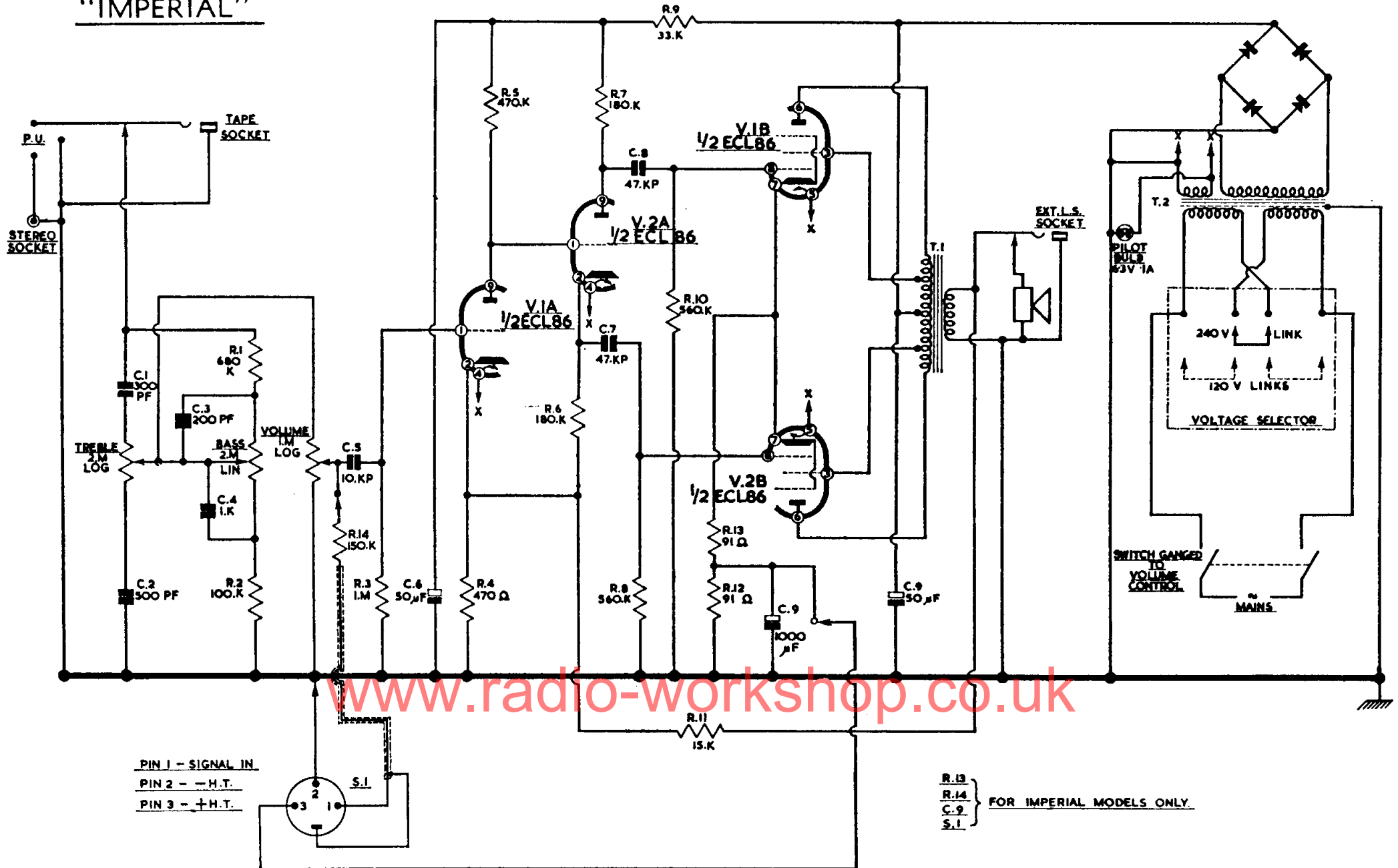

CIRCUIT DIAGRAM—DANSETTE "IMPERIAL" RECORD REPRODUCER

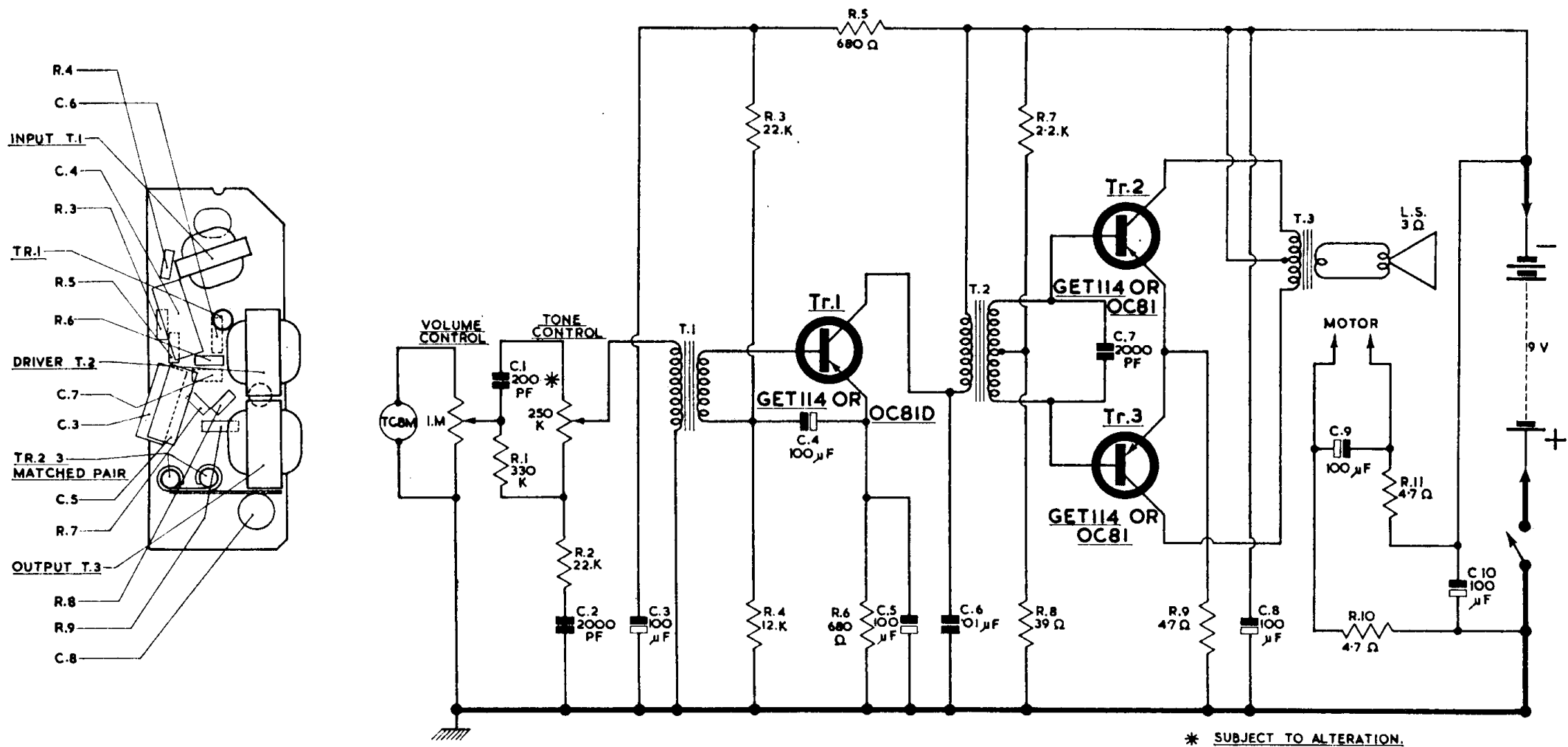

CIRCUIT DIAGRAM AND LAY-OUT DIAGRAMS—DANSETTE "CARLTON" RECORD REPRODUCER

www.radio-workshop.co.uk

Dansette "Carlton": Two-stage, three-transistor record reproducer for operation from 9-volt battery (six Ever Ready HP2 or equivalent), no-signal consumption about 60 mA. B.S.R. type UA25 record unit with "Ful-fi" cartridge type TC8H. Access to battery compartment by removing white battery cover on right hand side of instrument (coin-slotted screw). Transistors OC81D and OC81 or GET114. Weight 13¼ lb.