

CONFIDENTIAL

This Service Data is for the information of Appointed Ekco Dealers only and must not be copied.

EKCO SERVICE DATA

MODEL A239

See also Service News Sheets Nos.

Page 1 (in 8 pages)

MODEL A239 is a 6 valve (plus tuning indicator) superheterodyne receiver designed for the reception of A.M. signals on the Long, Medium and Short wavebands and for F.M. signals on the V.H.F. band (Band 2). Selection is made by a five position switch, which includes one position for gram operation.

For A.M. reception, provision is made for the connection of a conventional aerial and earth, or for using the braiding of the coaxial down lead of an F.M. aerial, if available.

For F.M. reception, an internal dipole is provided, together with a coaxial connector for an outdoor F.M. dipole.

Other special features include the short circuiting of the unused A.M. or F.M. I.F. channel as applicable, top cut at V4.B anode on A.M. only, and a compensated volume control to maintain bass response.

MAINS SUPPLY : 200-250 Volts, 50 c/s A.C.

MAINS CONSUMPTION : 298mA at 205 Volts.
278mA at 225 Volts.
248mA at 245 Volts.

CONTROLS : Front of cabinet, Left (upper) TONE CONTROL, Left (lower) VOLUME-ON/OFF, Right (upper) TUNING, Right (lower) WAVEBAND SELECTOR and GRAM SWITCH.

PILOT LAMPS : Pygmy lamp, 250 Volts, 15 Watts.

VALVES :

V1	ECC85	V.H.F. Amplifier and Mixer.
V2	ECH81	Frequency Changer (A.M.), I.F. Amplifier (F.M.).
V3	EF85	I.F. Amplifier.
V4	EABC80	Ratio Detector, Demodulator (A.M.) and A.F. Amp.
V5	EL84	A.F. Output.
V6	EZ80	H.T. Rectifier.
V7	DM70	Electronic Tuning Indicator.

All valve bases are type B9A except V7 which is type B8D.

WAVEBAND COVERAGE :

F.M. Band 2 (V.H.F.)	—	87.5—100 Mc/s.
A.M. S.W.	16—50 metres.	6.0—17.9 Mc/s.
M.W.	185—560 metres.	535—1630 Kc/s.
L.W.	995—2060 metres.	145—302 Kc/s.

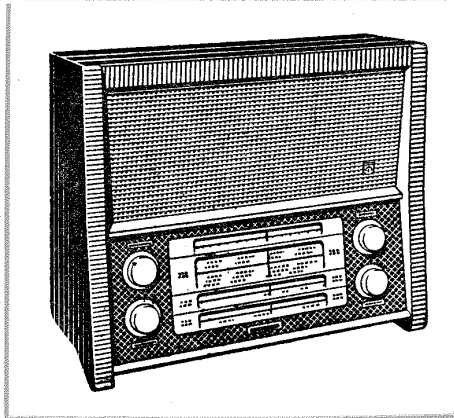

INTERMEDIATE FREQUENCY : F.M. Channel 10.7 Mc/s.
A.M. Channels 460 Kc/s.

L.S. IMPEDANCE : 3 ohms at 400 c/s.

Sockets are provided at the rear of the receiver to facilitate the connection of a low impedance external loudspeaker.

OUTPUT : 3 Watts (approx.).

CIRCUIT DETAILS**F.M. OPERATION****R.F. AND MIXER STAGES**

F.M. signals from the dipole are passed via the loading coil L1 (or direct from an external dipole) to the aerial coils L3.L4 and then to the control grid of V1.A, operating as a neutralised R.F. triode. L5 and C2 connected between the anode and grid of V1.A provide a means of neutralising the valve to prevent instability or oscillatory radiation. L2 and C1 form an effective I.F. rejection circuit in the aerial input.

The amplified signal appearing at the anode of V1.A is fed via a pi matching network, consisting of L6.C6.C7 and C8, to the grid of a self oscillating triode V1.B. The R.F. section of the tuning capacitor C7 and its padding capacitor C6 are shunted across the valve V1.A. A parallel fed Hartley circuit is employed in V1.B stage, the oscillator output frequency being higher than that of the incoming signal. C17 and C16 are the oscillator tuning capacitor, and its padder respectively.

In order to increase the gain of V1.B, a part of the resultant I.F. signal appearing at the anode is fed back to the grid circuit. The choke L31 prevents R.F. leakage from grid to earth but at the same time allows I.F. to pass.

INTERMEDIATE FREQUENCY STAGES

The I.F. signal at the anode of V1.B is fed via the 1st I.F. transformer L8.L9 and switch SW3.B to grid 1 of the heptode (V2) which operates as an I.F. Amplifier on F.M. The triode section of this valve is rendered inoperative by the switch SW3.A open-circuiting the H.T. feed to its anode.

From the heptode anode, the amplified I.F. signal is passed via a further I.F. transformer L22.L23 and switch SW2.A to the grid of V3 for amplification. L22 primary winding is in series with the A.M. primary L24 but the A.M. secondary L25 is short-circuited whilst on F.M. operation. This arrangement prevents I.F. signals at 460 Kc/s. from causing interference which might otherwise result from their passing to the detector stage.

On high signal inputs a voltage, built up across the resistor R39, is passed to the control grid of V3. This voltage then becomes additive to the existing fixed bias on the valve which, therefore, makes the grid more negative with respect to the cathode resulting in a limiting action on signal voltages above a pre-determined level. The amplified output from the valve V3 is, therefore, more constant.

RATIO DETECTOR

The 3rd I.F. transformer consists of three windings L26, L27 and L28. To the centre tap of L27, L28 applies a signal voltage that is in constant phase relation with the voltage in the primary winding L26.

The voltage across L27, which is derived from the coupling to L26, is 90 degrees out of phase with that across L26 when the F.M. signal is at the mean frequency, and the sum total of signal voltages at the ends of L27 are equal and opposite. If this is applied to the opposed diodes of V4, it produces a constant output. When the signal voltage in L26 deviates above or below the mean frequency, the phase in L27 changes relative to the degree of deviation. The total voltage, $\frac{1}{2} L27 \pm L28$, applied to one diode will, therefore, increase, while the voltage to the other will decrease. The resultant output from the diodes will vary in direct sympathy with the deviation of the F.M. signal, i.e., in accordance with the audio content.

The reservoir action of the capacitor C51 across the two diodes assists in removing any A.M. content in the output.

A stabilising voltage is fed from the diode (pin 2) of V4 to the suppressor grid (pin 9) of V3 as A.G.C.

A.F. AND OUTPUT STAGES

A.F. output from the ratio detector valve is taken from a tertiary winding L28 and fed to the triode grid of V4 for amplification. Connected in the audio feed is a de-emphasis network comprising R14 and C50, which is included to restore the frequency characteristic to its correct level. At high audio frequencies the capacitor C50 presents a low impedance to give a potentiometer effect which attenuates the high frequencies. At low audio frequencies, however, the capacitor has a high impedance, with a negligible reduction in signal. Thus the amplitude of the high audio frequencies is returned to the correct level. Due to compensation inherent in the circuit the corrector circuit is designed to have a time constant of only 25 μ s. Audio output from the triode anode (V4) is then passed to the grid of V5 for final amplification.

Negative feedback in the output circuit is provided by the speaker transformer secondary, and is fed back to the grid of V4 via R35. C64 connected between the anode and cathode of V5 acts as a tone correcting component.

TONE CONTROL, PICK-UP AND TAPE RECORDER

CIRCUITS

The main tone correction circuit consists of R19, R20, R21, C54, and C55 with R19 as the variable component. C55 is a top cut capacitor so that moving the slider of R19 towards the 'earthy' end of its traverse (anti-clockwise) increases the amplitude of the base frequencies. In the reverse direction (clockwise on the control), the top frequencies are favoured.

Bass compensation is provided for by the network consisting of R22, C58 and C59 in conjunction with the tapped volume control R23.

There is provision for the connection of a high output pick-up to terminals located at the rear of the receiver chassis. The pick-up input is fed, via a selector switch SW3.G, R21, C56 and the volume control, to the grid of the A.F. triode. R29 in parallel with the pick-up terminals provides impedance matching for the pick-up.

In the A.F. feed provision is made for the connection of a Tape Recorder, to allow direct recordings to be taken from the radio.

BIAS

Fixed bias is used for V2, V3 and V5 and grid leak bias (R25) on V1, A and V4. The fixed bias is developed across R36, by-passed by C65, and fed via R38, an element of the potentiometer formed by R38, R16 and R13.

TUNING INDICATOR

To facilitate accurate station adjustment, an electronic tuning indicator V7 is incorporated.

V7 is negatively driven so that internal fluorescence diminishes with a corresponding increase in the signal input level.

Filament volts are supplied from the heater winding of T2, via a dropping resistor R33, and a steady D.C. potential is applied to the anode via R32, R27 from the main H.T. line.

POWER SUPPLIES

The mains transformer T2 is tapped for operation from three different input voltages, and across the 250 V. terminals is connected an indicator lamp LPI.

The anodes of a full-wave rectifier V6 are connected to the H.T. secondary winding, and the D.C. output is smoothed by C62, C63 and R28.

Heater supplies are taken from a separate L.T. winding which has two resistors R40, R41, in series, connected across the winding to balance out any hum. The centre tap of the resistors is taken to earth.

A.M. OPERATION

R.F. MIXER STAGE

A.M. signals from the aerial pass to the control grid of V2 (heptode section) via a common L.W./M.W. aerial coil primary and the appropriate secondary, according to the setting of the selector switch SW3.B. On the S.W. band signals are fed to the primary L11 via C18 and then, as on the other two bands, through the switch to the control grid.

L10 and C17 form an effective I.F. rejector circuit. The secondary windings L12, L13 and L15 are shunted by trimmers with the S.W. coil L12 having, in addition to the trimmer, a variable iron dust core for alignment purposes.

The A.M. section of the main tuning capacitor C24 is shunted across one of the three tuned circuits as determined by the setting of the selector switch SW3.A.

In the local oscillator section of V2 are three individually tuned H.F. transformers, covering the L.W., M.W., and S.W. bands. The secondary of each transformer is selected by the switch SW3.D which connects it to the triode grid. Primary windings are selected by the switch SW3.F and connect to the triode anode. The oscillator section of the main tuning capacitor is shunted across each grid coil by the switch SW3.E.

Note : On A.M. operation VI is inoperative, the H.T. feed being open circuited by the switch SW3.C.

INTERMEDIATE FREQUENCY STAGES

The oscillator and incoming signals combine to form an I.F. signal at the anode of V2 which is fed via the 1st I.F. transformer L24, L25 and SW2.A to the grid of V3, operating as a straightforward I.F. amplifier.

As on F.M. operation, L24 primary is in series with the F.M. primary winding L22, but the secondary L23 is short circuited by the switch SW2.A, when on A.M. operation.

The amplified I.F. signal at the anode of V3 is passed via a further I.F. transformer L29, L30 to one diode of V4 for demodulation.

A.F. AND OUTPUT STAGES

The rectified A.F. output from the demodulator diode is fed via the tone control circuits and volume control to the grid of the common L.F. triode (V4).

A whistle filter C37 is incorporated in the A.F. output circuit of V4 this decoupling effectively reduces the upper frequency response and, therefore, eliminates the possibility of whistle due to adjacent channel interference. From the anode of the triode the signal is fed via C61 to the grid of V4 for final amplification.

A.G.C.

A part of the D.C. voltage from the rectified signal, developed across R13, is fed back as bias to the control grids of V2 and V3, and is also used to operate the electronic tuning indicator V7. The Output and Power Supply circuits are common to both A.M. and F.M. operation having been described previously under F.M. Operation.

ALIGNMENT (I). Procedure for Frequency Modulated (F.M.) band. Using F.M./A.M. Signal Generator.

I.F. 10.7 Mc/s. Switch to F.M. band and tune the receiver to 87.5 Mc/s. Inject a 10.7 Mc/s. signal ± 25 Kc/s. deviation with 400 c.p.s. tone, via a 150 pf capacitor between the 2nd I.F., secondary (L23) and chassis. Tune L26 and L27 for maximum response.

Switch to A.M. 30% mod. on generator and tune L27 for the sharpest minimum response.

Switch generator back to F.M. with ± 100 Kc/s. deviation. Retune L26 for maximum response and L27 for minimum distortion. Check bandwidth for 6dB loss in output with ± 5 Kc/s. deviation. Bandwidth should then be greater than ± 100 Kc/s. Increase generator deviation to ± 25 Kc/s. and inject signal to 1st I.F. secondary (L9). Tune L22 and L23 for maximum response. Check bandwidth for 6dB loss with ± 5 Kc/s. deviation and retune for symmetry if necessary.

Inject signal into aerial coil (L3) and tune L9, L8 for maximum response (see following note). The I.F. signal level at the aerial coil (L3) will be approx. the same as that injected into L9. Check bandwidth as before.

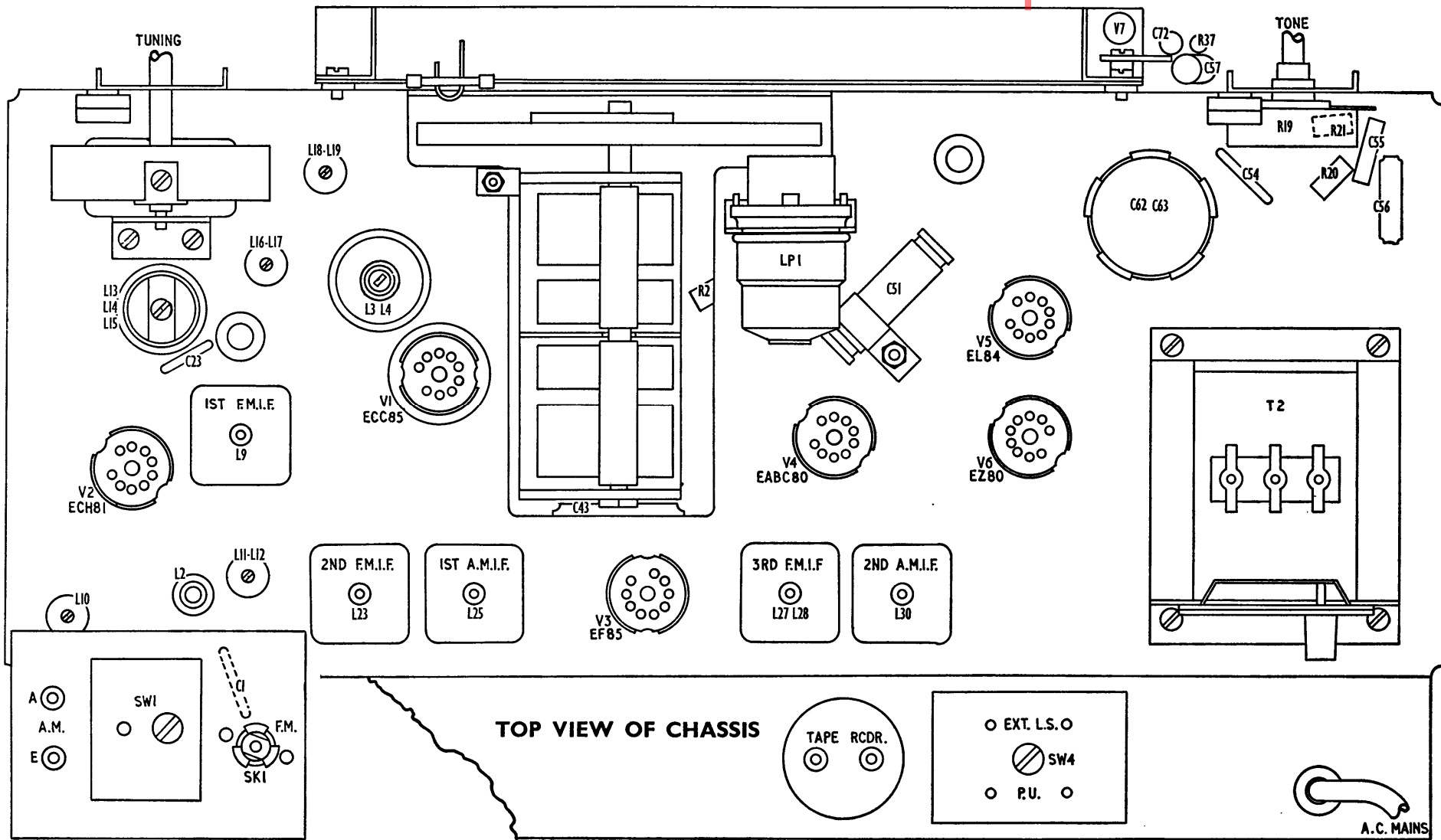

Note. If the I.F. rejector coil L2 is already aligned, the signal level available at L9 and L8 may be insufficient to allow accurate adjustment of these coils. In order to overcome this, without increasing the generator output, it is necessary to short circuit L2 whilst adjusting L9 and L8. Inject 10.7 Mc/s. signal into the VHF aerial socket and tune L2 for minimum response.

R.F. 87—100 Mc/s.

- (a) Tune receiver to 90 Mc/s. and inject a signal at the same frequency, ± 25 Kc/s. deviation, to the VHF aerial input socket. Tune L7 for maximum response on first peak from core fully in position and check for image at 111.4 Mc/s.
- (b) Tune receiver to 98 Mc/s. and inject a signal at the same frequency. Adjust C16 for maximum response on first peak from minimum capacity of trimmer. Check for image at 119.4 Mc/s. and calibration at 90 Mc/s.
- (c) Tune receiver to 90 Mc/s. and inject signal at same frequency. Tune L6 for maximum response, retuning receiver if necessary. Adjust C6 for maximum response at 98 Mc/s. retuning receiver if necessary. Check at 90 Mc/s.
- (d) Tune receiver to 94 Mc/s. and inject a signal at the same frequency. Tune L4 for maximum response.
- (e) Disconnect R2 (27K) from H.T. and connect it to the negative bias point of R36 (100 ohms). Tune L5 for minimum response at 94 Mc/s. Reconnect R2 to the H.T. supply.
- (f) Connect a valve milli-voltmeter of high sensitivity across C8 and tune C11 for minimum oscillator voltage.
- (g) Repeat (a) and (b) for accurate calibration and (c) for maximum response.

ALIGNMENT (2). Procedure for F.M. Band using A.M. Signal Source.

I.F. ALIGNMENT

Switch to the F.M. band and tune the receiver to 87.5 Mc/s. Connect a high sensitivity voltmeter (20,000 ohms/volt) and points (a) and (b) of the 'test jig' meter shown in the diagrams, across C51 (8mf top of chassis, adjacent to V4). Connect point (c) to the junction of L28 and C49 (.0003mf below chassis, adjacent to V4). Inject a 10.7 Mc/s. c.w. signal between the 2nd I.F. secondary (L23) and chassis via a 150pf capacitor. Tune L26 and L27 for maximum response on the voltmeter. Retune L27 for minimum response on 'test jig' meter. Disconnect 'test jig' meter from the receiver. Tune L22.L23.L9.L8 and L2 as described in the main alignment instructions using a 10.7 Mc/s. signal without modulation and the voltmeter as an output meter.

R.F. ALIGNMENT

The procedure given in the previous R.F. instructions should be followed using a voltmeter across C51 (8mf) as an output meter, and an A.M. signal source.

Notes on F.M. Section for Service in the Field

(i) Valve replacement

The ECH81 and EF85 valves may generally be replaced without realignment of associated circuits as can the ECC85 where the signal strength is reasonably strong. When replacing the EABC80, a listening check should be made to ensure that the noise rejection is not impaired.

(ii) I.F. transformer replacement

The first and second I.F. transformers can, when replaced, in an emergency be re-aligned on an F.M. transmission, taking care to check and, if necessary, adjust the trimming so that tuning is even on both sides of resonance as shown by the tuning indicator.

When setting up the third I.F. transformer after replacement, whilst the primary can be tuned normally, the secondary should be tuned carefully to ensure that the strongest of the three tuning points is used. This applies particularly if the signal is strong.

(iii) Repairs to VHF unit

Replacement of by-pass condensers, etc. need not affect alignment and, in particular if no damage has occurred to the R.F. neutralising coil L6 or oscillator neutralising trimmer C11 then these adjustments should not be altered.

ALIGNMENT (3). Procedure for A.M. bands.

I.F. ALIGNMENT

Switch to M.W. and fully mesh the tuning capacitor. Inject a 460 Kc/s. signal (mod. 30% at 400 c.p.s.) across C24. Connect a 47K damping resistor across L29 and tune L30 for maximum response. Transfer the damping resistor to L25 and tune L29 for maximum response. Connect the resistor across L29 and tune L25 for maximum response. Transfer resistor to L25 and tune L24 for maximum response. Check for overall symmetry and bandwidth. Inject 460 Kc/s. signal into the aerial socket and tune L10 for minimum response.

R.F. ALIGNMENT

- (a) Switch to L.W. and tune receiver to 300 Kc/s. Adjust a 300 Kc/s. signal (mod. 30% at 400 c.p.s.) into aerial. Inject C35 and C22 for maximum response. Check calibration and tracking at 150 Kc/s., 200 Kc/s. and 250 Kc/s.
- (b) Switch to M.W. and tune receiver to 1200 Kc/s. Inject a 1200 Kc/s. signal into the aerial. Adjust C32 for maximum response. Tune receiver to 600 Kc/s. and inject a signal at the same frequency. Tune L18 for maximum response. Check at 1200 Kc/s. and re-adjust C32 if necessary. Tune receiver to 1300 Kc/s. and inject a signal at the same frequency. Adjust C21 for maximum response. Check calibration and tracking at 800 Kc/s.

(c) Switch to S.W. and tune receiver to 7.0 Mc/s. Inject 7.0 Mc/s. signal into the aerial and tune L16 for maximum response on first peak approaching from core fully out position. Tune receiver to 16 Mc/s. and inject a signal at the same frequency. Adjust C30 for maximum response on first peak approaching from minimum capacity of trimmer. Check at 7.0 Mc/s., retuning L16 if necessary. Check for images at 7.0 and 16.0 Mc/s. Tune receiver to 7.0 Mc/s. and inject a signal at the same frequency. Tune L12 for maximum response. Adjust C19 for maximum response at 16 Mc/s. and check at 7.0 Mc/s., retuning L12, if necessary. Check for calibration and tracking at 12 and 17.55 Mc/s., the latter mark being 6.61 in. from the datum line.

CHASSIS REMOVAL

Remove the back cover, then the four front control knobs. Release the internal dipole clips from the loading coil L1. Remove four 2BA chassis retaining screws from the base of the cabinet. Finally withdraw chassis to the extent of the L.S. leads.

DRIVE CORD DETAILS

The diagram gives full instruction for fitting a replacement cord. Before using new cord, it should be stretched to prevent slack drive developing in later use.

SERVICE NOTES

COMPONENT REPLACEMENT

Care should be taken to ensure that leads are not displaced when replacing faulty parts, especially in V1 and its associated circuit.

It is also important to ensure that when replacing parts directly concerned with the F.M. circuit, they have the same value and operating characteristics as the original component.

ERRATA.

CIRCUIT DIAGRAM, PAGE 2.

The test point TP/F at the negative end of C51 should read TP/A.

TOP VIEW OF CHASSIS, PAGE 4.

Coils L27, L28 at the top of the 3rd F.M.I.F. should read L26, L28.

UNDERNEATH VIEW OF CHASSIS, PAGE 6.

3rd F.M.I.F. L26 should read L27.

ELECTROLYTIC CAPACITORS

Should either C51 or C65 be replaced they must be fitted so that the positive tag connects to the chassis as shown in the circuit diagram.

VOLTAGE AND CURRENT DATA

VALVE	TYPE	ANODE		SCREEN		CATHODE		HEATERS
		V	mA	V	mA	V	mA	V
V1.A V1.B	ECC85	117 209	4.05 9.0	— —	— —	— —	4.05 9.0	6.3
V2 V2 (triode)	ECH81	245 95	1.8 4.15	86 —	4.8 —	— —	10.8	6.3
V3	EF85	220	9.6	85	2.3	—	11.9	6.3
V4	EABC80	90	0.6	—	—	—	0.6	6.3
V5	EL84	231	38	217	4.85	—	43	6.3
V6	EZ80	255 A.C.	—	—	—	260	64.5	6.3
V7	DM70	70	0.155	—	—	—	0.155	1.3

Conditions. All the above measurements were taken on an AVO model 8 (20,000 ohms per volt sensitivity on D.C.). The receiver tuned to 94 Mc/s. for V1 measurements and 1 Mc/s. for the remaining valves.

Other measurements.

Grid bias (EL84) receiver tuned to 1 Mc/s. 6.6 Volts.
Grid bias (EL84) receiver tuned to 94 Mc/s. 6.9 Volts.

VALVE BASE DATA

VALVE	CIRCUIT REF.	1	2	3	4	5	6	7	8	9	BASE
ECC85	V1.A-B	A ¹¹	G ¹¹	K ¹¹	H	H	A ¹	G ¹	K	I.S	B9A
ECH81	V2	G2.G4	G1	K	H	H	A	G3	At	Gt	B9A
EF85	V3	K	G1	K	H	H	I.S	A	G2	G3	B9A
EABC80	V4	Ad ¹¹¹	Ad ¹¹	Kd ¹¹	H	H	Ad ¹	Ktd ^{1d¹¹¹}	Gt	At	B9A
EL84	V5	—	G1	K.G3	H	H	—	A	—	G2	B9A
EZ80	V6	A	I.C	K	H	H	I.C	A	I.C	I.C	B9A
DM70	V7	G	I.C	—	H	H	—	—	A	—	—

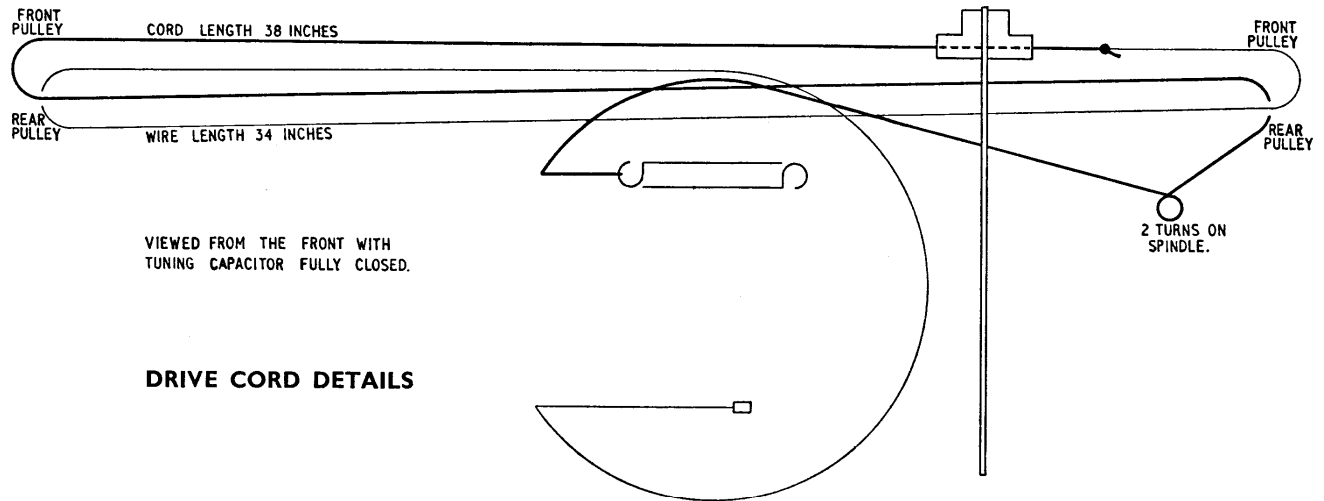

D.C. RESISTANCE OF WINDINGS

Circuit Ref.	Coil	Ohms	Part No.
L1	Loading	*	DP22957
L2	F.M. I.F. Rej.	*	DP22959
L3	Aer. Pri.	*	DP22794
L4	Aer. Sec.	*	DP22879
L5	Neutralising	*	DP22785
L6	Intervalve	*	B49195
L7	Oscillator	*	DP22783
L8	1st F.M. I.F. Pri.	*	DP22780
L9	1st F.M. I.F. Sec.	*	DP22780
L10	A.M. I.F. Rej.	21.5	DP22878
L11	S.W. Aer. Pri.	2.9	DP22876
L12	S.W. Aer. Sec.	*	DP22876
L13	M.W. Aer. Sec.	2.9	DP22870
L14	M.W./L.W. Aer. Pri.	50	DP22870
L15	L.W. Aer. Sec.	30	DP22877
L16	S.W. Osc. Sec.	*	DP22877
L17	S.W. Osc. Pri.	*	DP22877
L18	M.W. Osc. Sec.	3.2	DP22875
L19	M.W. Osc. Pri.	1.6	DP22875

Circuit Ref.	Coil	Ohms	Part No.
L20	L.W. Osc. Pri.	3.6	DP22875
L21	L.W. Osc. Sec.	6.4	DP22875
L22	2nd F.M. I.F.	*	DP22781
L23	2nd F.M. I.F.	*	DP22781
L24	1st A.M. I.F. Pri.	12	DP22779
L25	1st A.M. I.F. Sec.	10.5	DP22779
L26	3rd F.M. I.F.	*	DP22782
L27	3rd F.M. I.F.	*	DP22782
L28	3rd F.M. I.F. (T)	*	DP22779
L29	2nd A.M. I.F. Pri.	*	DP22779
L30	2nd A.M. I.F. Sec	*	DP22779
L31	V.H.F. choke	1	DP22983
T1	Pri.	710	SA5193
T1	Sec.	*	SA5193
T2	Pri.	30	SA5342
T2	H.T. Sec.	160 + 170	SA5342
T2	L.T. Sec.	*	SA5342

*Less than 1 ohm.

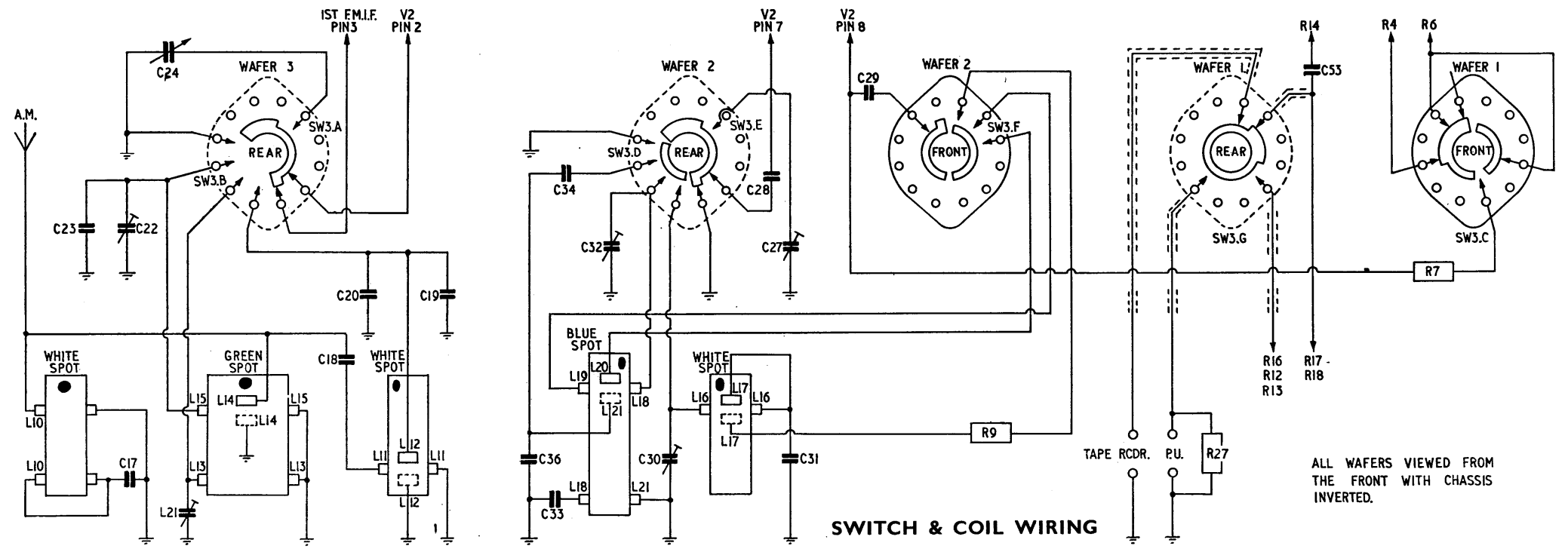
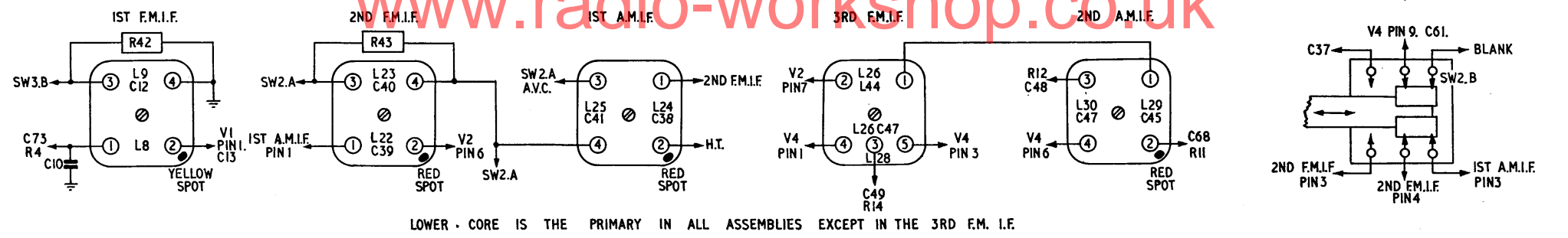

SERVICE DEPT., E. K. COLE Ltd.,
 Somerton Works, Arterial Road,
 Southend-on-Sea
 'Phone: Southend 42296
 Head Office: Ekco Works, Southend-on-Sea

SCOTTISH SERVICE DEPOT:
 17, Cadogan Street,
 Glasgow, C.2.
 'Phone: Central 3633/4

NORTHERN SERVICE DEPOT:
 55, Whitworth Street,
 Manchester, 1
 'Phone: Central 6711/2

MIDLAND SERVICE DEPOT:
 11, Brook Street,
 Birmingham, 3
 'Phone: Central 2505/6

CONFIDENTIAL

This Service Data is for the information of Appointed Ekco Dealers only and must not be copied.

EKCO SERVICE DATA

A239 ADDENDUM

See also Service News Sheets Nos.

Page 1 (in 4 pages)

Later versions of the A239 receiver have increased sensitivity on Band 2 and, in addition, are fitted with an internal aerial, which consists of a rotatable Ferrite rod, for operation on the Long and Medium wavebands.

A new type of 'magic eye' indicator is also incorporated, replacing the DM70 used in earlier models.

WAVEBAND COVERAGE

F.M. Band 2 (V.H.F.)	—	87.5—100 Mc/s.
A.M. S.W.	15.9—50 metres	6.0—18.9 Mc/s.
M.W.	181.8—571.4 metres	525—1650 Kc/s.
L.W.	1034.4—2000 metres	150—290 Kc/s.

CONTROLS

Front of cabinet, Left (upper) TONE, Left (lower) VOLUME-ON/OFF, Right (upper) TUNING, Right (lower) WAVEBAND SELECTOR and GRAM SWITCH, Side ROD AERIAL.

VALVES

Same as for earlier models with the exception of V7, which is now a MULLARD type EM80 (Tuning Indicator).

CIRCUIT DETAILS

The aerial coils L13 and L15 which cover the Medium and Long wavebands respectively, are positioned at the ends of the Ferrite rod. Both coils are returned to chassis via a resistor R33, and not direct as in earlier models.

The Ferrite rod aerial is rotatable through approx. 320°, being controlled by a knob at the side of the receiver.

A new type of tuning indicator is fitted, the grid of which is fed by a small voltage from the demodulation circuit. C57 is a grid by-pass capacitor which eliminates any modulation ripple that may be present. Filament volts are supplied from the heater winding of T2 and a steady D.C. potential is applied to the anode via R32, from the main H.T. line.

The remaining stages of the receiver are virtually the same as used in earlier models, with the exception of some adjustments in component values.

CHASSIS REMOVAL AND DRIVE CORD

As for earlier models.

DRIVE CORD FOR ROTATING AERIAL (see diagram)

Before fitting a new cord it should be stretched for approximately 24 hours to prevent slack drive developing in later use.

First set the side control spindle so that its flat face is downwards, then set the Ferrite rod aerial parallel to the rear edge of the chassis with the larger coil L15 at the outer position.

Tie one end of the cord to the tension spring and, with the spring at mid-distance between the pulleys and aerial spindle (as diagram), pass the cord over the rear pulley and wind $2\frac{1}{2}$ turns round the side spindle, passing the second turn through the cross-hole in the spindle.

Continue the cord over the front pulley and wind $3\frac{1}{2}$ turns round the aerial spindle, again passing the second turn through the cross-hole. Finish by fastening the cord to the other end of the spring, expanding the latter slightly to maintain tension. The aerial rod, the control spindle and the spring should be in the positions shown on the diagram.

Note.—At least one turn of cord should be left on the spindles in either extreme position to prevent chafing.

ALIGNMENT (F.M.)

The alignment on F.M. remains the same as for previous models.

ALIGNMENT (A.M.)

I.F.

As on previous models.

R.F.

(a) Switch to L.W. and inject into the aerial socket a signal of 275 Kc/s. Tune receiver to the same frequency then adjust C35 and C22 for maximum response.

Inject a signal of 150 Kc/s. and tune receiver to the same frequency. Adjust L15 for maximum response.

(b) Switch to M.W. and inject a signal at 1300 Kc/s., then tune receiver to the same frequency. Adjust C32 for maximum response.

Inject a signal at 600 Kc/s., and tune receiver to the same frequency. Adjust L18 for maximum response.

Inject a signal at 1300 Kc/s. and tune receiver to the same frequency. Adjust C21 for maximum response.

Check calibration and tracking at 800 Kc/s.

Inject a signal at 600 Kc/s. and tune receiver to the same frequency. Adjust L13 for maximum response.

(c) Switch to S.W. and inject a signal at 7.0 Mc/s. and tune receiver to the same frequency. Adjust L16 for maximum response on first peak approaching from core fully out.

Inject a signal at 16 Mc/s. and tune receiver to the same frequency, then adjust C30 for maximum response on first peak approaching from minimum capacity of trimmer.

Check at 7.0 Mc/s. and retune L16, if necessary. Check also for images at 7.0 and 16.0 Mc/s.

Inject a signal at 7.0 Mc/s. and tune receiver to the same frequency, then tune L12 for maximum response.

Adjust C19 for maximum response at 16.0 Mc/s., and check at 7.0 Mc/s., retuning L12, if necessary.

Check for calibration and tracking at 12 and 17.55 Mc/s., the latter mark being 6.61 inches from the datum line.

SERVICE NOTES

Additions and Changes (all models). A decoupling capacitor (C76, .001 mf) is connected between one side of the heater winding of T2 and chassis. A further decoupling capacitor (C75, .001 mf) is connected between the heater (pin 5) of V5 and chassis.

C10 feedback capacitor in the anode circuit of V1.B is reduced from 400 pf to 300 pf.

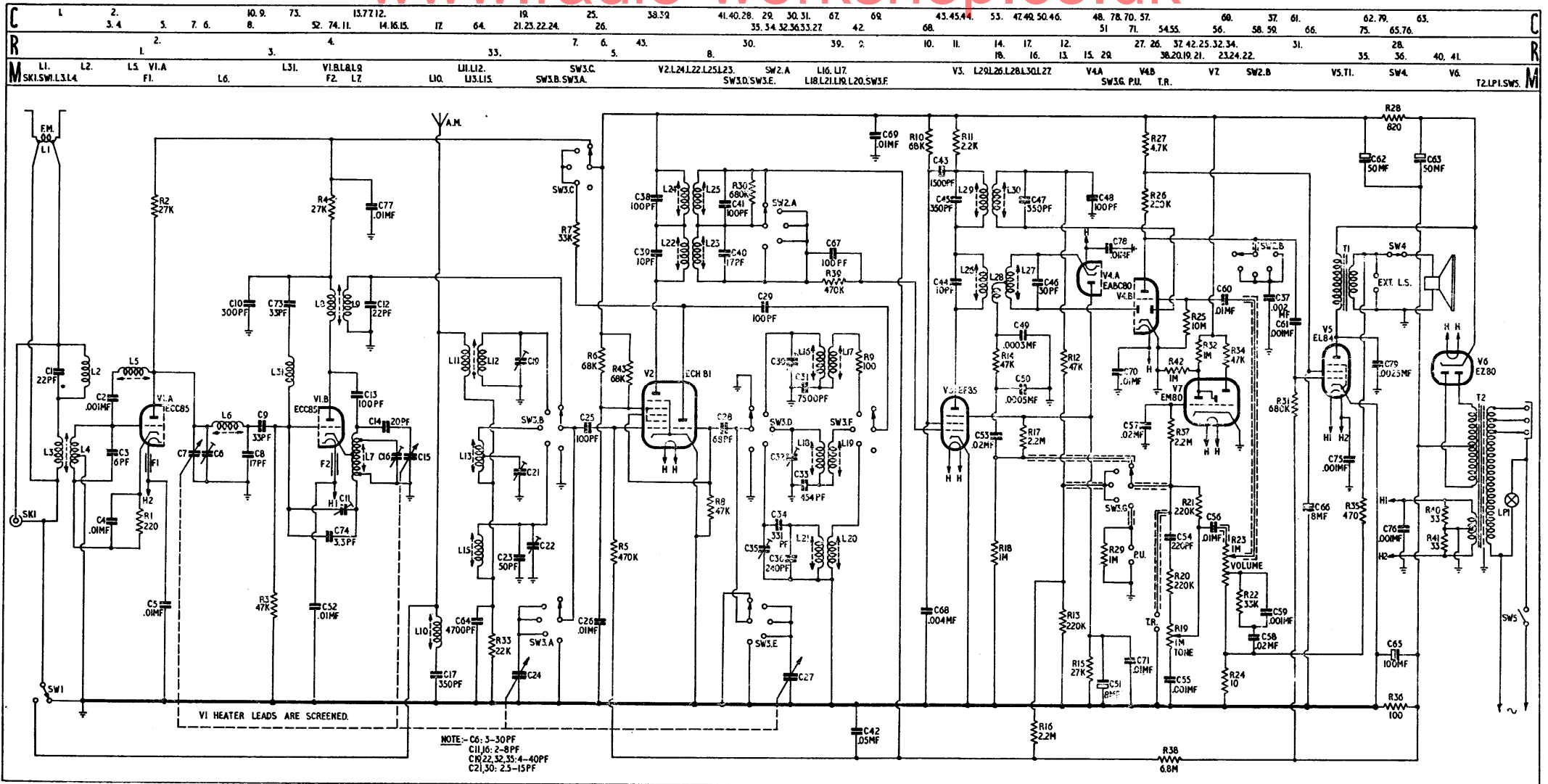

CIRCUIT DIAGRAM

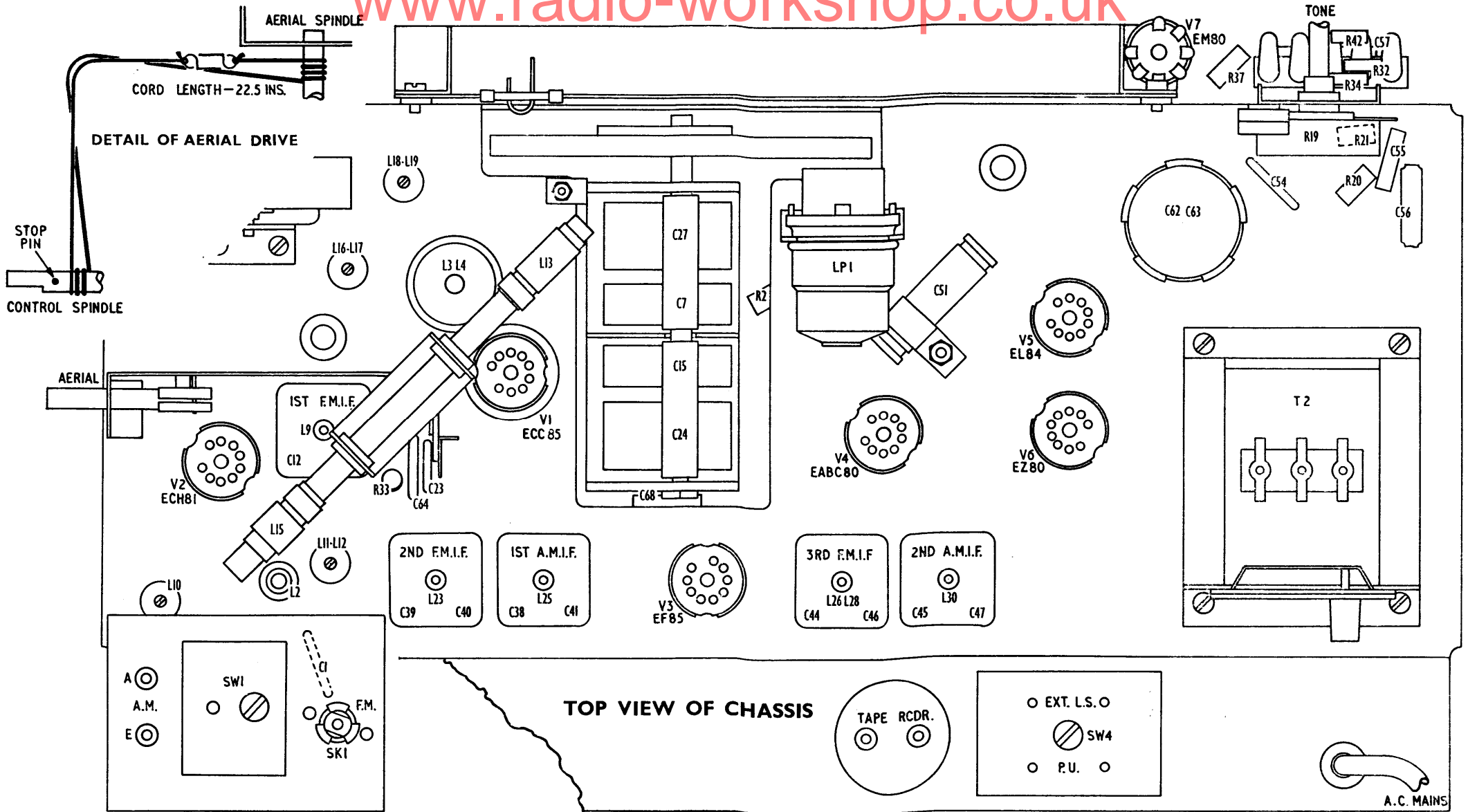

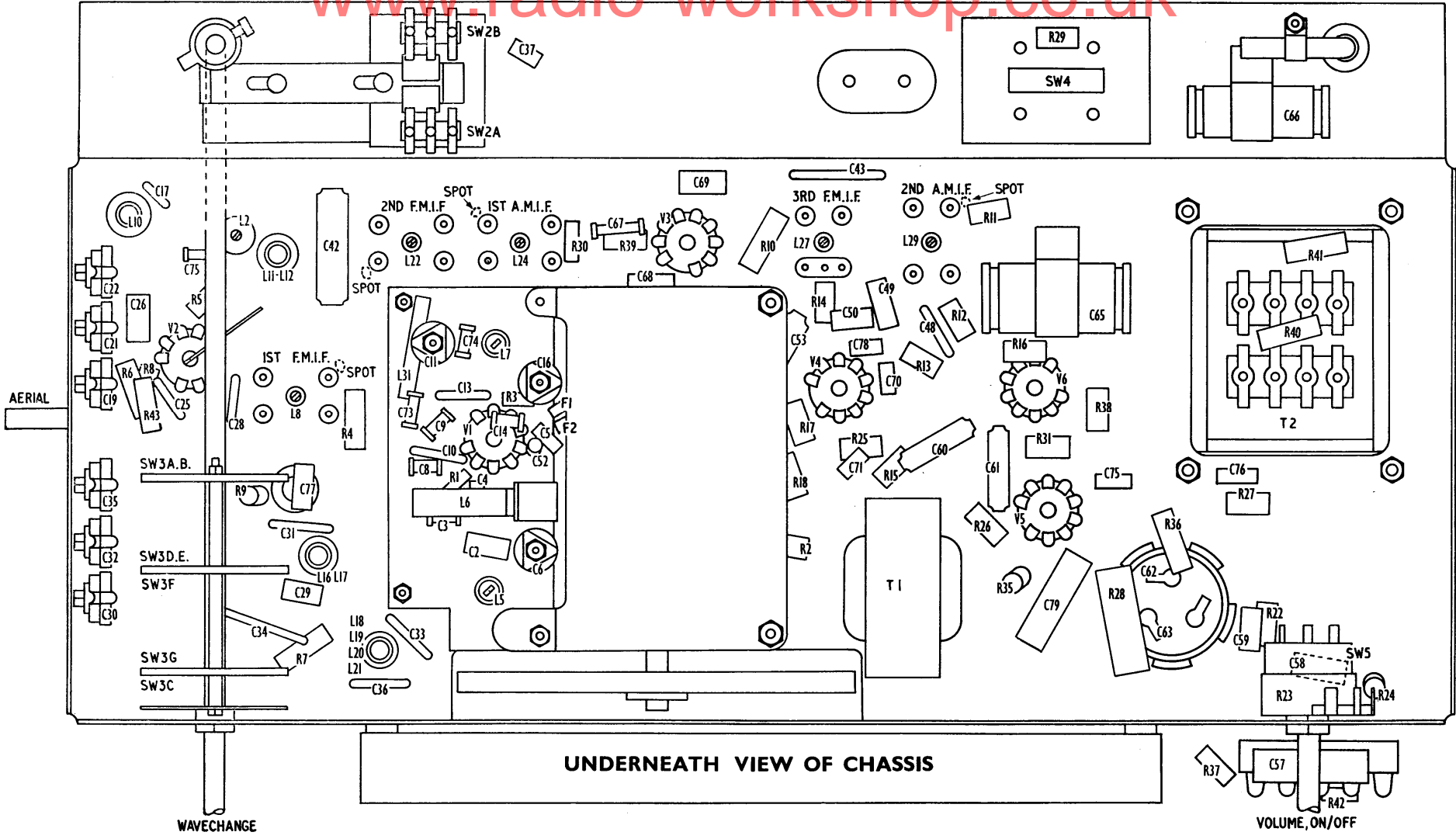

SERVICE DEPT., E. K. COLE Ltd.,
 Somerton Works, Arterial Road,
 Southend-on-Sea
 'Phone: Southend 42296
 Head Office: Ekco Works, Southend-on-Sea

SCOTTISH SERVICE DEPOT:
 17, Cadogan Street,
 Glasgow, C.2.
 'Phone: Central 3633/4

NORTHERN SERVICE DEPOT:
 55, Whitworth Street,
 Manchester, 1
 'Phone: Central 6711/2

MIDLAND SERVICE DEPOT:
 11, Brook Street,
 Birmingham, 3
 'Phone: Central 2505/6