

[All rights reserved. This service data sheet is the copyright of WIRELESS & ELECTRICAL TRADER and may not be reproduced, in whole or in part, without permission.]

Supplement to Wireless & Electrical Trader, 10 November 1956

"TRADER" SERVICE SHEET
1275

EVER READY "SKY KING"

Also Covering Berec "Jester"

EMPLYING an internal frame aerial, the Ever Ready "Sky King" is a 2-band all-dry battery portable. It is fitted with four Ever Ready valves. The bands covered are 194-550m and 920-2,000m.

The Berec "Jester" employs the same chassis as the "Sky King."

Release date and original price, both models: June, 1956, £10. Purchase tax and batteries extra.

CIRCUIT DESCRIPTION

Tuned frame aerial inputs **L2**, **C3** (M.W.) and **L2**, loading coil **L1**, **C3** (L.W.) precede heptode valve **V1** which operates as frequency changer with electron coupling.

Oscillator grid coils **L5** (M.W.) or **L5**, **L6** (L.W.) are tuned by **C9**. Parallel trimming by **C10** (M.W.) or **C10**, **C11** (L.W.); series tracking by **C14**, **C15** (M.W.) or **C12**, **C13** (L.W.). Reaction coupling from oscillator anode via **L7** (M.W.) and **L8** (L.W.) Oscillator stabilization by **R3**.

V2 is a variable-mu R.F. pentode operating as intermediate frequency amplifier with tuned transformer couplings **L3**, **L4** and **L9**, **L10**.

Intermediate frequency 470 kc/s. Diode signal detector is part of diode pentode valve **V3**. A.F. component in its rectified output is developed across volume control **R8**, which operates as diode load, and is passed via **C22** to **V3**.

Resistance-capacitance coupling by **R10**, **C25** and **R12** between **V3** and pentode output valve **V4**. Tone correction by **C26**. Bias for **V4** is developed across **R13** in the negative H.T. lead.

CIRCUIT ALIGNMENT

- 1.—Remove chassis from carrying case as instructed under "Dismantling." Switch receiver to L.W. and turn gang to maximum capacitance.
- 2.—Connect output meter across **T1** secondary winding. Connect output of signal generator between point X (location reference A2) and chassis.
- 3.—Feed in a 470 kc/s signal and adjust the cores of **L10** (C2), **L9** (D4), **L4** (B2) and **L3** (F4) for maximum output. When making an adjustment, set the core to the peak nearer the adjustment end of the coil former.
- 4.—Repeat the adjustments in operation

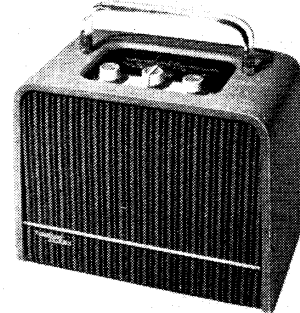

Appearance of the Ever Ready "Sky King."

COMPONENTS AND VALUES

CAPACITORS		Values	Locations
C1	L.W. aerial trim.	120pF	A2
C2	M.W. aerial trim.	25pF	A1
C3	Aerial tuning	523pF	A1
C4	V1 S.G. decoupling	0.1μF	F4
C5	A.G.C. decoupling	0.05μF	F3
C6	1st I.F.T. tuning	100pF	B2
C7		100pF	B2
C8	V1 osc. C.G.	80pF	F4
C9	Osc. tuning	523pF	A2
C10	M.W. osc. trim.	60pF	A2
C11	L.W. osc. trim.	120pF	A2
C12	L.W. osc. trackers	150pF	G4
C13		200pF	A2
C14	M.W. osc. trackers	350pF	G4
C15		200pF	A2
C16	H.T. decoupling	0.1μF	F4
C17	V2 S.G. decoupling	0.1μF	F4
C18	2nd I.F.T. tuning	100pF	C2
C19		100pF	C2
C20	I.F. by-passes	100pF	D4
C21		100pF	E3
C22	A.F. coupling	0.001μF	D3
C23	V3 S.G. decoupling	0.1μF	D4
C24	I.F. by-pass	100pF	D3
C25	A.F. coupling	0.001μF	D3
C26	Tone corrector	0.001μF	B2
C27	Battery by-pass	8μF	F3

- 3 until no further improvement results. Disconnect signal generator.
- 5.—Replace chassis in carrying case, and place battery in its normal position. Check that with gang at maximum capacitance the cursor coincides with the inside line of the two vertical lines (Continued col. 1 overleaf)

RESISTORS		Values	Locations
R1	V1 S.G. H.T. feed	150kΩ	F4
R2	V1 osc. C.G.	27kΩ	F3
R3	Osc. stabilizer	1kΩ	F4
R4	Osc. H.T. feed	33kΩ	F4
R5	V2 S.G. H.T. feed	33kΩ	E4
R6	A.G.C. decoupling	2.2MΩ	E4
R7	I.F. stopper	47kΩ	D4
R8	Volume control	500kΩ	E3
R9	V3 C.G.	10MΩ	D3
R10	V3 anode load	1MΩ	D4
R11	V3 S.G. H.T. feed	4.7MΩ	D4
R12	V4 C.G.	4.7MΩ	D3
R13	V4 G.B.	560Ω	D4

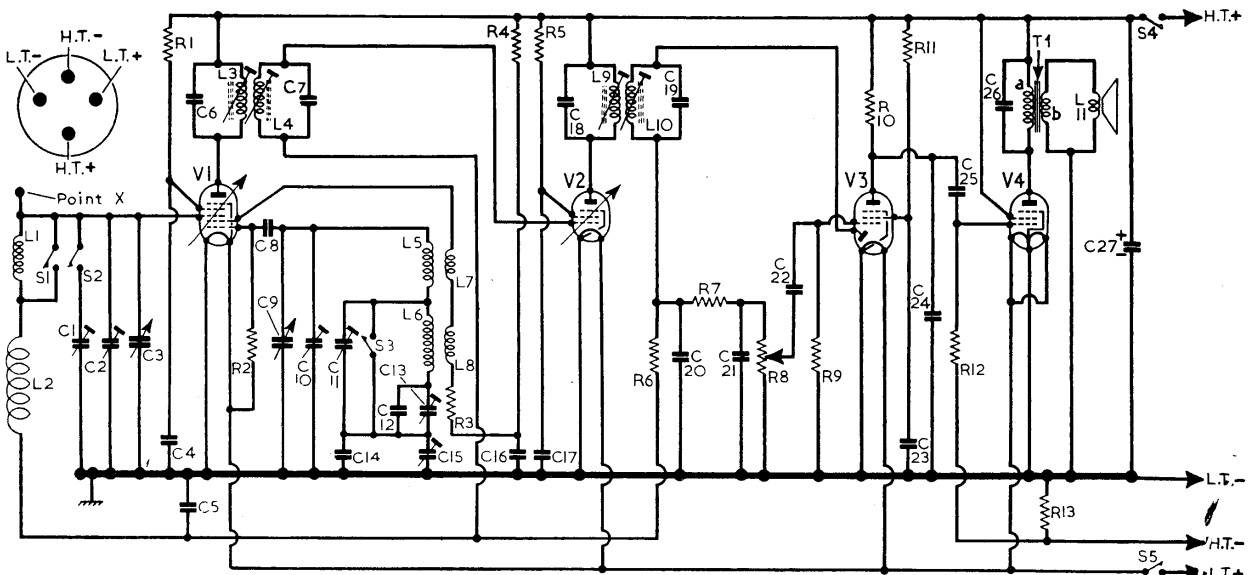

Circuit of Ever Ready "Sky King." Battery plug connections are shown in the top left corner where the plug is viewed from the free ends of its pins.

1275 EVER READY "Sky King"

Supplement to Wireless & Electrical Trader, 10 November 1956

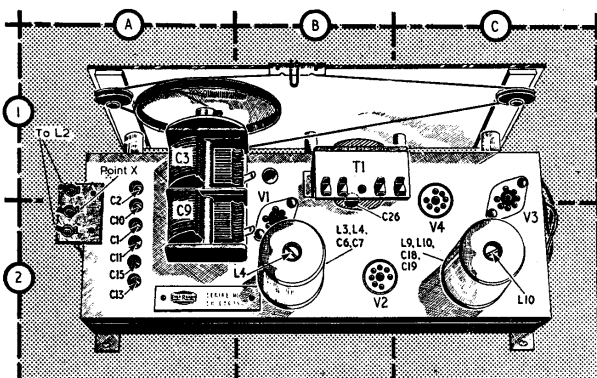

Plan illustration of chassis. The connections to the frame aerial L2, and an alignment point X are shown in locations A1, A2.

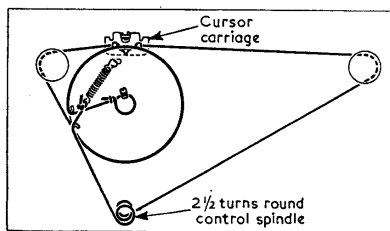

Sketch of the drive cord system.

a new battery, but with no signal input. Except where otherwise indicated, voltages were measured on the 100V range of a 1,000 ohms-per-volt meter, chassis being the negative connection. The voltage measured across R13 was 5V (positive meter connection to chassis). The total H.T. current was 10mA and the total L.T. current was 125mA.

OTHER COMPONENTS		Values in Ohms	Locations
L1	L.W. loading coil...	1.66	G4
L2	Frame aerial coil	2.25	A1
L3	1st I.F.T.	{ Pri. 9.7	B2
L4		{ Sec. 9.7	B2
L5	Osc. tuning coils	2.15	G4
L6		1.9	G4
L7		2.2	G4
L8	Osc. reaction coils	1.93	G4
L9		{ Pri. 9.7	C2
L10	{ Sec. 9.7	C2	
T1	O.P. trans.	500-0	B1
S1-S5	Band/batt. sw. ...	—	B1 E3

DISMANTLING

Removing Chassis.—Remove three control knobs (centre knob secured by grub screw; outer ones by spring clips); lay carrying case on its face and disconnect frame aerial and speaker leads; remove two wood screws securing rear edge of chassis to cabinet; remove two 4BA nuts (with plain washers and spacing pillars) securing carrying handle and scale backing plate to cabinet; remove handle and withdraw chassis.

Valve	Anode		Screen	
	V	mA	V	mA
V1 DK96	85	0.5	67*	0.1
	Oscillator 31 1.65			
V2 DF96	85	1.5	67*	0.5
V3 DAF96	38*	0.047	29*	0.018
V4 DL96	82	4.7	85	1.0

*Measured with electronic voltmeter.

Circuit Alignment—continued

- at the high wavelength end of the tuning scale.
- 5.—Connect signal generator leads to a 6in-diameter coupling loop consisting of twenty turns of 20 s.w.g. insulated wire, and place the loop parallel to and about 12in away from the front of the case.
- 7.—Switch receiver to M.W. and tune it to calibration mark between 200m and 225m on M.W. tuning scale. Feed in a 1,400 kc/s (214.3m) signal and adjust C10 (A2) and C2 (A1) for maximum.
- 8.—Tune receiver to 500m, feed in a 600 kc/s signal and adjust C15 (A2) for maximum output.
- 9.—Repeat the adjustments in operations 7 and 8, rocking the gang when adjusting C15 for optimum gain.
- 10.—Switch receiver to L.W. and tune it to 1,700m. Feed in a 176.5 kc/s signal and adjust C13 (A2) for maximum.
- 11.—Tune receiver to 1,000m, feed in a 300 kc/s signal and adjust C11 (A2) and C1 (A2) for maximum output.
- 12.—Repeat the adjustments in operations 10 and 11, rocking the gang while adjusting C13 for optimum gain.

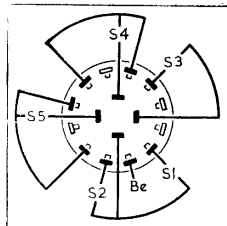

Diagram of the band/battery switch unit as viewed from rear of inverted chassis.

VALVE ANALYSIS

Valve voltages and currents given in the table (next col.) are derived from the manufacturers' information. They were measured with the receiver operating from

GENERAL NOTES

Switches.—S1-S3 are the band switches and S4, S5 are the battery switches ganged in a single rotary unit beneath the chassis. This unit is identified in the under-chassis illustration and shown in detail in col. 2.

Battery.—That recommended by the manufacturers is an Ever Ready Batrymax B136 combined H.T. and L.T. battery rated at 90V and 1.5V respectively.

Drive Cord Replacement.—About 34in of good quality fishing line, plaited and waxed, is required for a new drive cord. It should be run as shown in the sketch in this column which shows the drive system as viewed from the rear of an upright chassis with gang at maximum.

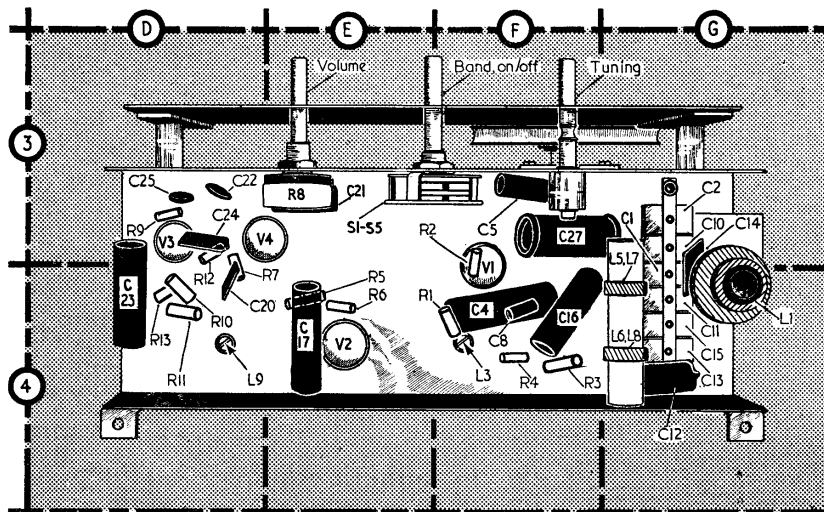
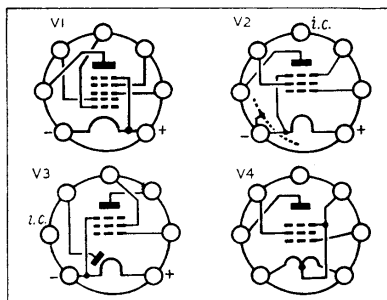

Above: Underside illustration of chassis. The switch unit S1-S5 in E3 is shown in detail in column 2. Left: Valve base connection diagrams.