

# CIRCUIT DIAGRAM

www.radio-workshop.co.uk

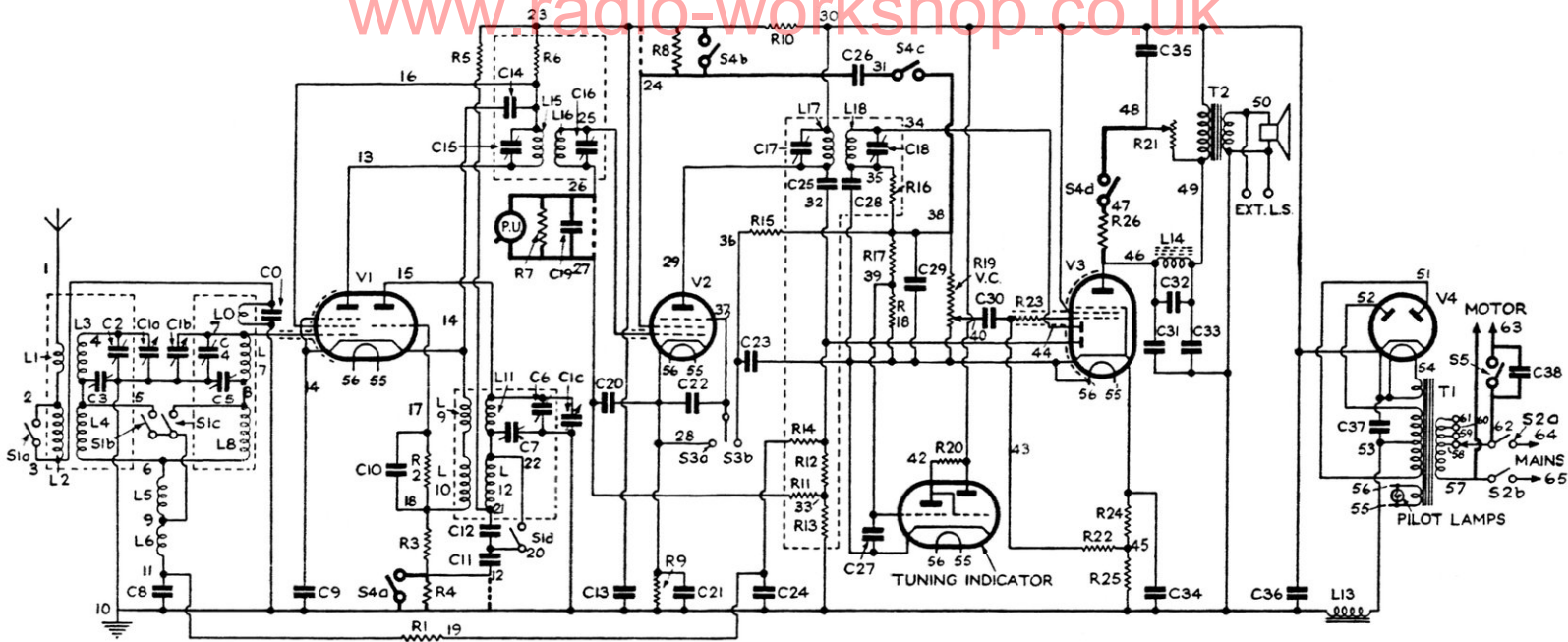

## TABLE OF VOLTAGES

COMPONENT	TYPE	ELECTRODE	TEST POINT	IN SQUARE	VOLTAGE		Gram	
					No Signal	Strong Signal		
V1	Mazda AC/TP	Pentode Anode	13	13 J	168	200	200	
		Screen	16	13 J	160	170	200	
		Cathode	14	13 J	3.8	1	20	
		Triode Anode	15	13 H	80	80	72	
V2	Mazda AC/VP2	Anode	29	9 H	235	235	235	
		Screen	24	8 H	220	230	200	
		Cathode	28	8 J	2.5	1	2.5	
V3	Mazda AC/2PenDD	Anode	46	6 H	210	210	210	
		Screen	30	5 H	235	235	235	
		Cathode	56	5 H	16	16	16	
V4	Mazda UU4	Cathode	30	2 H	350	350	350	
		Tuning Indicator	Anode	30	26 M	235	235	235
			Anode	42	26 N	40	40	40
		Cathode	56	26 N	16	16	16	