



# SERVICE NOTES—Model Q.AC3

[www.radio-workshop.co.uk](http://www.radio-workshop.co.uk)

## PYE Q.AC3 RECEIVER

SHEET No. 2

Issued May, 1937

### GENERAL SERVICE PROCEDURE

First make sure that the receiver is correctly installed, and that the aerial and earth system is satisfactory.

Next check the power supply, and see that the red lead on the voltage adjustment panel on the mains transformer is set to the correct voltage tap.

Then check the valves by comparing their characteristics with the makers' published figures, if suitable apparatus is available, or alternatively by the substitution of a set of valves known to be good.

When the possibility of faulty installation, power supply or valves has been eliminated, the various circuits of the receiver are systematically analysed, either by checking the operating conditions of each valve in turn, or by a stage by stage test with a signal generator or oscillator.

In this manner the trouble is located to a particular circuit and each associated component is tested in the order that the particular symptoms suggest.

Service data is presented below and overleaf in a form particularly convenient for the Service Engineer.

#### Operating Conditions

The voltage and current readings given in the Circuit Analysis are normal under no-signal conditions, when valves of average characteristics are fitted. Voltages are measured from the chassis, and all readings are taken with the mains input stated below applied to the particular tapping on the mains transformer.

Input 100 volts to the 100	volts tapping
” 110 ” ” ” 110	” ”
” 125 ” ” ” 115-135	” ”
” 143 ” ” ” 136-150	” ”
” 207 ” ” ” 200-215	” ”
” 225 ” ” ” 216-235	” ”
” 243 ” ” ” 236-250	” ”

A lower or higher input voltage will give proportionately lower or higher readings.

## CIRCUIT ANALYSIS

All readings are with no signals being received. Voltages measured from the chassis with 1,000 ohms per volt meter.

Valve	Circuit	Voltage	Current	Associated components.
F.C. Valve (V1) Ever Ready A36A (Metallized)	Anode Screen Control grid Cathode Oscillator anode Oscillator grid	260 (248) 57 (50)  2 51 (43)	5.3 (4.5) 2.4 (2.2)   2.5 (2.3)	C6, C7 and T1 primary. C15 and R3. C1, C4, C5, C13, C14, R2, L3, L5, L6, S2, S3, and A.V.C. circuit. C15, C16 and R4. C22, L7, L9, R7 and S6. C2, C8, C9, C10, C18, C19, C20, C21, R5, R6, S4, S5, L8, L10 and L11.
I.F. Valve (V2) Ever Ready A50P (Metallized)	Anode Screen Grid Cathode	260 (246) 260 (250)  4.0 (5.0)	9.2 (9.0) 3.4 (3.2)  	C11, C29 and T2 primary. Main H.T. C7, C23, R9, T1 secondary and A.V.C. circuit. C24, R8.
Detector and A.F. Valve (V3) Ever Ready A23A (Met.)	Anode Grid Signal diode A.V.C. diode Cathode	76 (71)    1.8	1.3 (1.3)	C31, C34, R17, and R18. Screened leads C26, C27, C28, C30. R1, R13, R14, R15. S7, S8 and S9. C12 and T2 secondary. C29, R9 and R19. C32 and R16
Output valve (V4) Ever Ready A70D (Clear)	Anode Screen Control grid Cathode	239 (225) 260 (250)  5.5 (6.1)	33 (27) 4.5 (3.4)	C33, C36, C37, C38. R20, L12, S10 and T3 primary. Main H.T. C35, C34. R21 and R22. C39 and R23.
Power rectifier (V5) Ever Ready A11D	Each Anode Cathode	{350 volts A.C.} (310) 390 v.		T4 secondary. T4 (4 volt winding) C40, C41, L15 and H.T. + circuit.
Electric Eye Tuning Indicator (T.I) Ever Ready A39A (Clear)	Target Triode Anode Triode grid Cathode	260 (248) 20  1.8	0.2 0.1	Main H.T. + R10. C25, R11 and R12. C32 and R16.

The figures in brackets under Voltage and Current are applicable to receivers fitted with S11D type Rectifiers.

## CONDENSERS

Circuit indication	Specification	Location	Component number
C1	Aerial tuning condenser	Fig. 8	80069
C2	Oscillator tuning condenser	" 8	80069
C3	465 kilocycles Filter trimmer	" 8	80000
C4	S.W. aerial coil trimmer	" 8	80000
C5	M.W. " " trimmer	" 8	80000
C6	First I.F. transformer primary trimmer	" 8	80001
C7	" " secondary "	" 8	80001
C8	M.W. oscillator coil trimmer	" 8	80000
C9	M.W. oscillator padding trimmer	" 8	80001
C10	L.W. oscillator padding trimmer	" 8	80064
C11	Second I.F. transformer primary trimmer	" 8	80001
C12	" " secondary "	" 8	80001
C13	.05 mfd. tubular 350 v. D.C. working	" 9	68014
C14	.00001 mfd. mica	" 8	66005
C15	.1 mfd. tubular 350 v. D.C. working	" 9	68020
C16	.1 mfd. " " " "	" 9	68020
C17	.1 mfd. " " " "	" 9	68020
C18	.0001 mfd. mica	" 9	66035
C19	.00055 mfd. mica	" 9	66004
C20	.00002 mfd. mica	" 8	66006
C21	.005 mfd. mica	" 9	66105
C22	2 mfd. tubular 350 v. D.C. working electrolytic	" 9	67009
C23	.05 mfd. tubular 350 v. D.C. working	" 9	68014
C24	.1 mfd. tubular " " " "	" 9	68020
C25	.1 mfd. " " " "	" 9	68020
C26	.00005 mfd. mica	" 8	66036
C27	" " tubular " " " "	" 9	66036
C28	.01 mfd. tubular 450 v. D.C. working	" 9	68005
C29	.0001 mfd. mica	" 9	66035
C30	.0002 mfd. mica	" 9	66003
C31	2 mfd electrolytic 300 v. D.C. working	" 9	67009
C32	20 mfd. electrolytic 6 v. D.C. working	" 9	67013
C33	.025 mfd. tubular 350 v. D.C. working	" 9	68013
C34	.025 mfd. " " " "	" 9	68013
C35	.0005 mfd. mica	" 9	66039
C36	.002 mfd. mica	" 9	66041
C37	.025 mfd. tubular 350 v. D.C. working	" 9	68013
C38	.001 mfd. " " 450 v. D.C.	" 9	68000
C39	50 mfd. electrolytic 12 v. D.C. working	" 9	67005
C40 } C41 }	16 + 8 mfd. electrolytic 450 v. D.C. working	" 10	67062

## RESISTANCES

Circuit indication	Specification	Colour Code			Tolerance	Location	Component number
		Body	Tip	Dot			
R1	.5 megohm Volume control	Green	Black	Yellow	±20%	Fig. 9	81026
R2	110,000 ohms	Brown	Brown	Yellow	±20%	" 9	71962
R3	80,000 ohms	Grey	Black	Orange	±10%	" 9	71939
R4	200 ohms	Red	Black	Brown	±10%	" 9	71943
R5	50 ohms	Green	Black	Black	±10%	" 9	71959
R6	25,000 ohms	Red	Green	Orange	±10%	" 9	71908
R7	80,000 ohms	Grey	Black	Orange	±10%	" 9	71939
R8	300 ohms	Orange	Black	Brown	±10%	" 9	71942
R8*	400 ohms	Yellow	Black	Brown	±10%	" 9	71942
R9	1.1 megohm	Brown	Brown	Green	±20%	" 9	71900
R10	2.1 megohm	Red	Brown	Green	±20%	" 10	71902
R11	2.1 megohm	Red	Brown	Green	±20%	" 9	71902
R12	510,000 ohms	Green	Brown	Yellow	±20%	" 9	71944
R13	110,000 ohms	Brown	Brown	Yellow	±20%	" 8	71962
R14	510,000 ohms	Green	Brown	Yellow	±20%	" 9	71944
R15	510,000 ohms	Green	Brown	Yellow	±20%	" 9	71944
R16	1,000 ohms	Brown	Black	Red	±10%	" 9	71914
R17	25,000 ohms	Red	Green	Orange	±10%	" 9	71908
R18	110,000 ohms	Brown	Brown	Yellow	±20%	" 9	71960
R19	1.1 megohm	Brown	Brown	Green	±20%	" 9	71900
R20	20,000 ohms	Red	Black	Orange	±10%	" 9	71932
R21	260,000 ohms	Red	Blue	Yellow	±20%	" 9	71945
R22	25,000 ohms	Red	Green	Orange	±10%	" 9	71918
R23	150 ohms	Brown	Green	Brown	±10%	" 9	71969
R23*	200 ohms	Red	Green	Brown	±10%	" 9	71943

\* Receivers fitted with S11D type rectifier only.

## INDUCTANCES AND TRANSFORMERS

Circuit indication	Specification	Location	Component number
L1	465 kilocycles filter coil .. .. .	Fig. 8	78092
L2	S.W. aerial coupling coil .. .. .	Fig. 8	78100
L3	S.W. tuned aerial coil .. .. .		
L4 (+ L2)	M.W. and L.W. aerial coupling coil .. .. .		
L5 (+ L3)	M.W. tuned aerial coil .. .. .	Fig. 8	78101
L6 (+ L5 + L3)	L.W. tuned aerial coil .. .. .		
L7	S.W. osc. coupling coil .. .. .		
L8	S.W. tuned osc. coil .. .. .	Fig. 8	78101
L9 (+ L7)	M.W. and L.W. osc. coupling coil .. .. .		
L10 (+ L8)	M.W. tuned osc. coil .. .. .		
L11 (+ L10 + L8)	L.W. tuned osc. coil .. .. .	Fig. 9	78099
L12	Heterodyne filter coil .. .. .		
L13	Speaker speech coil .. .. .		
L14	Speaker hum balancing coil .. .. .	Fig. 10	85023
L15	Speaker field coil .. .. .		
T1	First I.F. transformer: Primary 5.0 ohms .. .. . Secondary 5.0 ohms .. .. .	Fig. 8	77088
T2	Second I.F. transformer: Primary 5.0 ohms .. .. . Secondary 5.0 ohms .. .. .	Fig. 8	77089
T3	Output transformer: Primary 700 ohms .. .. . Secondary 0.3 ohms .. .. .	Fig. 9	77078
T4	Mains transformer: Primary 19 + 1.8 + 1.8 ohms .. .. . Secondary 380 + 398 ohms .. .. .	Fig. 8	77115
T4*	Both heater windings below 1 ohm .. .. . Mains transformer: Primary 18.6 + 1.8 + 1.8 ohms .. .. . Secondary 299 + 297 ohms .. .. . Both heater windings below 1 ohm .. .. .	Fig. 8	77085

\* Receivers fitted with S11D type rectifier only.

## SWITCH POSITIONS

	S1	S2	S3	S4	S5	S6	S7	S8	S9
Medium Waves	Open	Open	Closed	Open	Closed	Open	Open	Open	Open
Long Waves	Open	Open	Open	Open	Open	Open	Open	Open	Closed
Short Waves	Closed	Closed	Closed	Closed	Closed	Closed	Open	Open	Open
Gramophone	Open	Open	Open	Open	Open	Open	Closed	Closed	Open

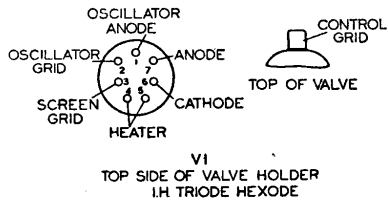

Fig. 1

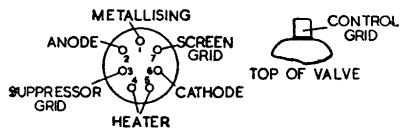

Fig. 2

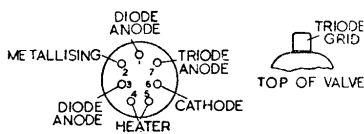

Fig. 3

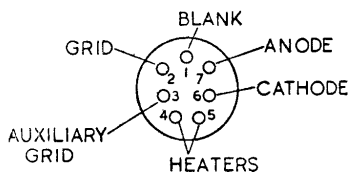

Fig. 4

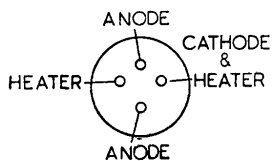

Fig. 5

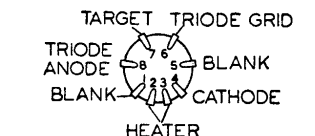

Fig. 6

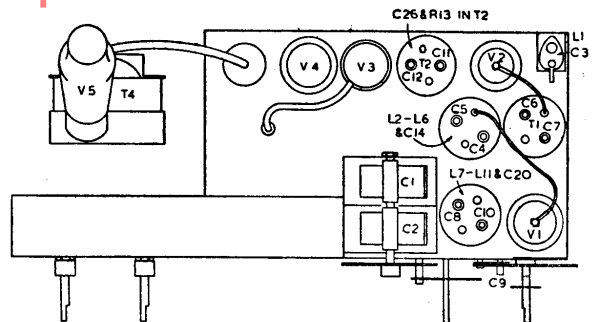
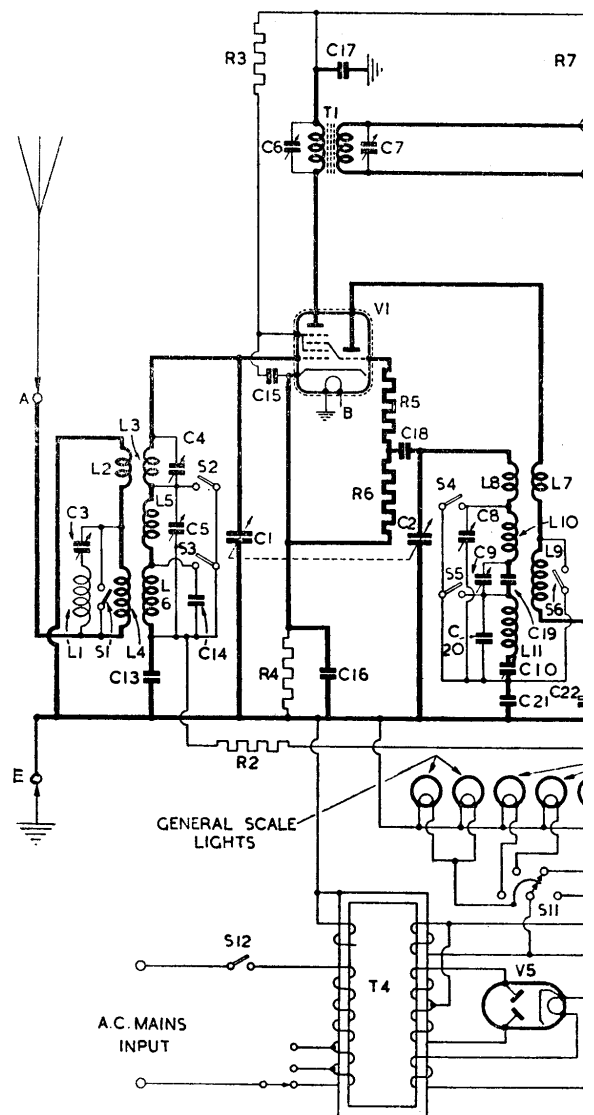

Fig. 8.



ALL RESISTANCES ARE COMPOSITE.  
VALVE METALLISING AND ALL SCREENED LEADS ARE EARTHED TO CHASSIS, EXCEPT V1 (TO CATHODE)

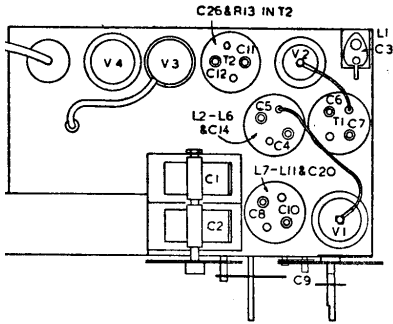

Fig. 8.

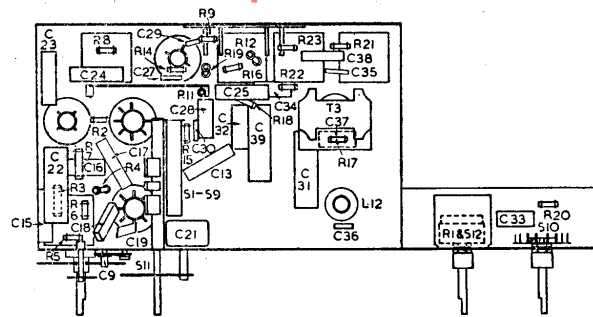
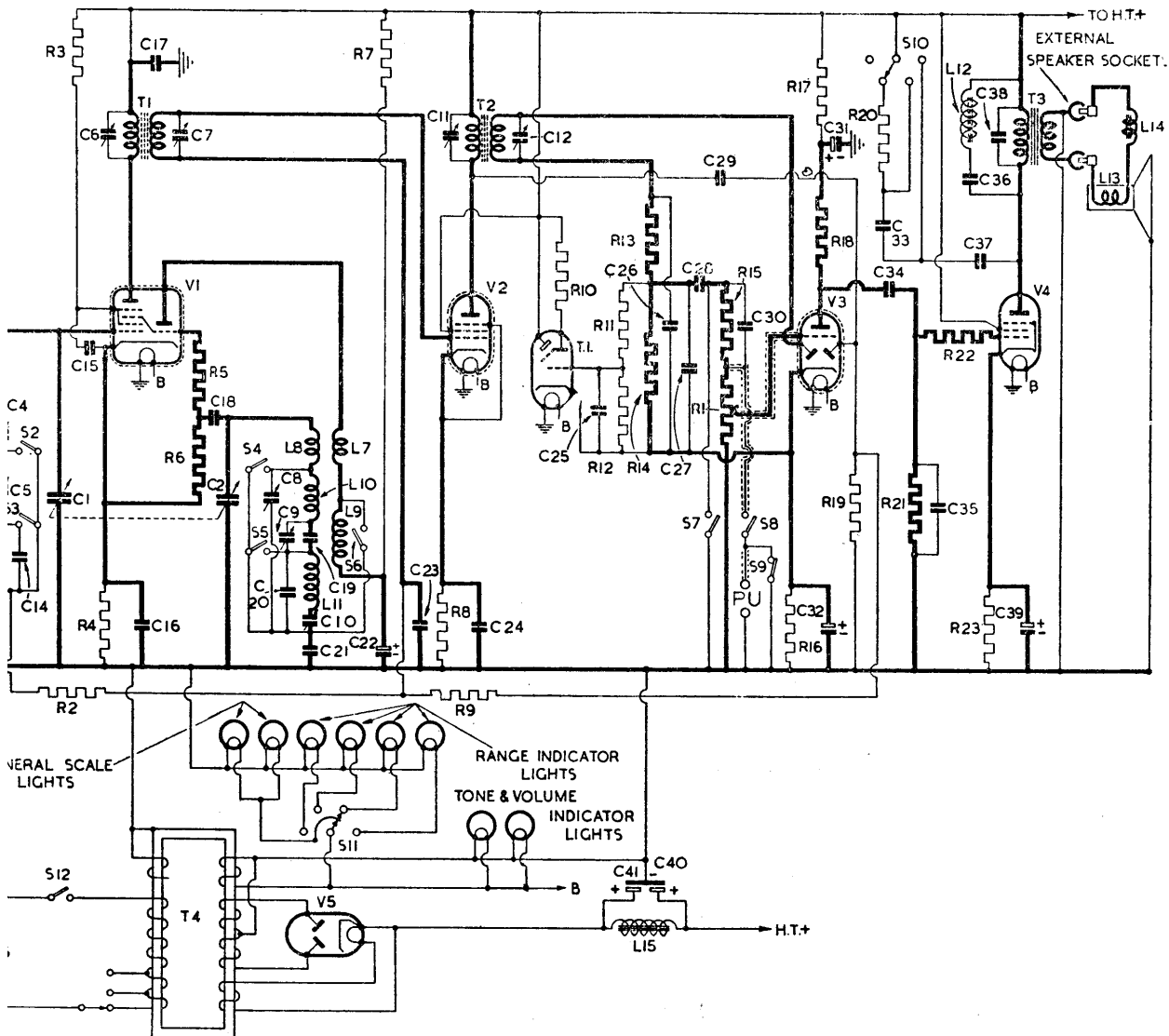

Fig. 9.



ARE COMPOSITE.  
ING AND ALL SCREENED LEADS ARE  
CHASSIS, EXCEPT V1 (TO CATHODE)

Fig. 7

## Alignment of the calibrated scale and gang condenser.

The calibrated glass tuning scale is held in position by four 4 BA screws. To adjust the dial these screws must be slackened and the dial adjusted until the tuning indicator is located in the centre of the circle at the top of the scale.

Rotate the tuning control knob in a clockwise direction until the gang is fully in mesh. This position can be ascertained by placing the flat end of a pencil or rod against the condenser vanes. When the gang is fully engaged the cursor should be on the setting mark at the top end of the M.W. scale. For adjustment of the cursor see paragraph "To fit new Gang Tracer."

## Adjusting the I.F. Circuits.

Any adjustments made to the I.F. circuit should be done before the signal frequency and oscillator circuits are adjusted.

The I.F. transformers are tuned to a frequency of 465 kilocycles (645 metres) so a modulated signal of this frequency should be applied between the frequency changer valve control grid and chassis, via a .002 mfd. condenser. The lead to the control grid terminal is removed and a  $\frac{1}{2}$  megohm resistance is connected between this valve terminal and the chassis. To stop the valve from oscillating, a condenser of 0.25 mfd. is connected between the oscillator anode and chassis.

An output meter, if of high impedance type, should be connected across the primary of the output transformer, or alternatively it may be connected to the loudspeaker sockets by means of a Pye "Match-all" transformer.

An insulated screwdriver will be required, such as supplied in the Pye "Trimkit."

Adjust the I.F. Trimming condensers in the following order, to give a maximum peak on the output meter. (1) C12, (2) C11, (3) C7, (4) C6.

## Adjusting the R.F. and Oscillating Circuits.

With the range change switch set to the S.W. position and the receiver tuned to 15 megacycles, apply a signal of this frequency (15 megacycles) and adjust the S.W. trimming condenser C4.

With the range change switch set to Medium Wave and the set tuned to 210 metres feed via a dummy aerial a signal of 1428 kilocycles frequency (210 metres) to the aerial socket and adjust the following condensers for maximum output in the following order C8, C5.

Tune the set to 520 metres and feed in a signal of frequency 577 kilocycles (520 metres). The medium wave padding condenser C9 should then be adjusted for maximum output. The trimming at 210 metres should then be rechecked.

With the range change switch set to the Long Wave position and the receiver tuned to 1800 metres apply a signal of frequency 166.5 kilocycles (1800 metres) and adjust the L.W. padding condenser C10.

## To tune the I.F. Filter.

Apply a signal of 465 kilocycles between the aerial and earth sockets and tune C3 for *minimum* output.

### SUMMARY OF TRIMMING PROCEDURE FOR R.F. & OSCILLATOR CIRCUITS

	Order of Adjustment	Short	Medium	Long
1.	Scale pointer		210 metres	
2.	Input signal to aerial terminal via dummy aerial		210 metres (1428 kcs)	
3.	Adjust trimmers (see Fig 11) for maximum output		C8	
4.			C5	
5.	Scale Pointer	15 megacycles	520 metres	1800 metres
6.	Input Signal	15 megacycles (20 metres)	520 metres (577 kcs)	1800 metres (166.5 kcs)
7.	Adjust padders (See Fig. 11) for maximum output	C4	C9	C10
8.	Repeat adjustments	5 to 7	1 to 7	5 to 7

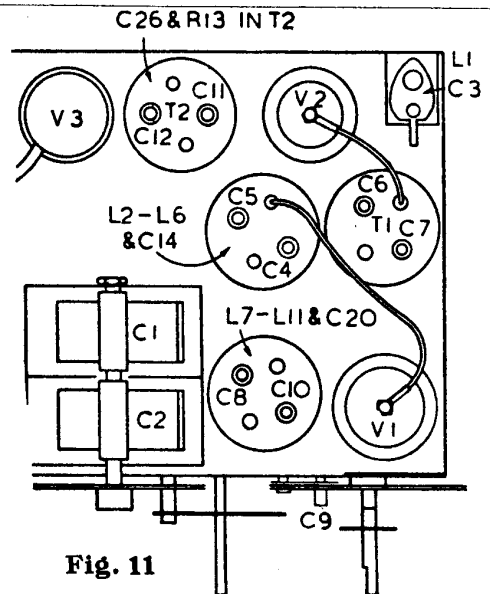

## Replacing and Adjusting Control Trace Wires.

DESIGNATIONS OF TRACE WIRE		
Trace	Length	Component No.
Tone control (Y)	16½"	41420
Volume control (Z)	27"	41421
Gang condenser (X + W)	X	41423
	W	41422

### To fit new Gang Condenser Traces X & W (Fig. 12).

First remove the dial by slackening the four holding screws. The drive intermediate discs (L Fig. 12) must be removed and the holding screws in the Gang Pulley (M and N) must be loosened.

The gang trace (X Fig. 12) has three loops one at each end and the third approximately midway between the two end loops. The middle loop should be fed down the groove in the gang pulley and hooked over the anchoring tag C (Fig. 12). The long end should then be taken around the gang pulley in a clock-wise direction and around the guide pulley eventually being hooked on the cursor anchoring tag B (Fig. 12).

The short end of the trace X should be taken around the gang pulley in an anticlockwise direction and around the drive pulley in an anticlockwise direction to the end of the spring marked A (Fig. 12).

The short gang trace W (Fig. 12) should first of all be hooked over the cursor anchor tag B (Fig. 12) before doing this the cursor should be placed at the top end of the scale. The trace should then be passed around the guide pulley and the loop at the other end hooked over the anchoring tag at the end of the spring A (Fig. 12). The trace can then be fed in a clockwise direction around the drive pulley by a method similar to that adopted when fitting a bicycle chain on a gear wheel.

The gang should then be placed with the rotor vanes fully in mesh as per the instructions given in paragraph two of "Alignment of the Calibrated Scale and Gang" and when the index lines up with the max. mark on the scale then the grub screws on the gang pulley (M and N Fig. 12) should be tightened.

If the cursor will not travel the full scale width and the drive stops need adjusting, this can be carried out by loosening the drive stop bracket retaining screw O (Fig. 12) and adjusting the position of the bracket.

### Fitting new Volume Control Trace Z (Fig. 12).

Place small loop at the end of the trace over the anchoring tag E (Fig. 12). Pass the trace around the guide pulleys, remove brass collar fitted to the volume control spindle and place the large loop at the end of the trace over the volume control spindle (D Fig. 12). The brass collar should then be replaced and the trace wire first fed through the groove in the collar and then around the spindle in a clockwise direction (See drawing Fig. 12). To adjust the shutter E turn the volume control fully clockwise and adjust the brass collar D so that the "Volume" sector on the scale is fully illuminated. When this has been done the collar should be pressed firmly against the backing spring and the retaining screw should be tightened.

### Fitting new Tone Control Trace Y (Fig. 12).

Place small loop at the end of the trace over the anchoring tag G (Fig. 12). Pass the trace around the guide pulley and loop the other end over the tone control spindle F (Fig. 12). The "retaining" screw holding the brass collar to the tone control spindle should be loosened, the wire fed through the groove in the collar and around the inside of the bush in the collar in an anti-clockwise direction. The position of the Tone Control shutter can be adjusted by rotating this brass collar and then when the position of this shutter has been adjusted, the "retaining" screw should be tightened. When the Tone Control is turned fully anti-clockwise the "Tone" sector should be illuminated to position 1.

### Adjusting the R.F. Oscillator and I.F. Circuits.

The Q.AC3 receiver incorporates a tuned signal frequency circuit a tuned oscillator and four tuned intermediate frequency circuits.

The trimmers are accurately adjusted on specially constructed apparatus when the receiver is manufactured and should not be touched unless:—

- (1) All voltages, currents, components and valves have been checked and found to be up to standard.
- (2) The efficiency of the receiver has been found to be below standard for selectivity and sensitivity when compared with other standard models.
- (3) Accurate equipment is available for their re-adjustment.

All adjustments should be made with:

- (1) Volume control at maximum.
- (2) The applied signal attenuated so that the input is not strong enough to operate the A.V.C. circuit.
- (3) An output meter connected to the output stage.

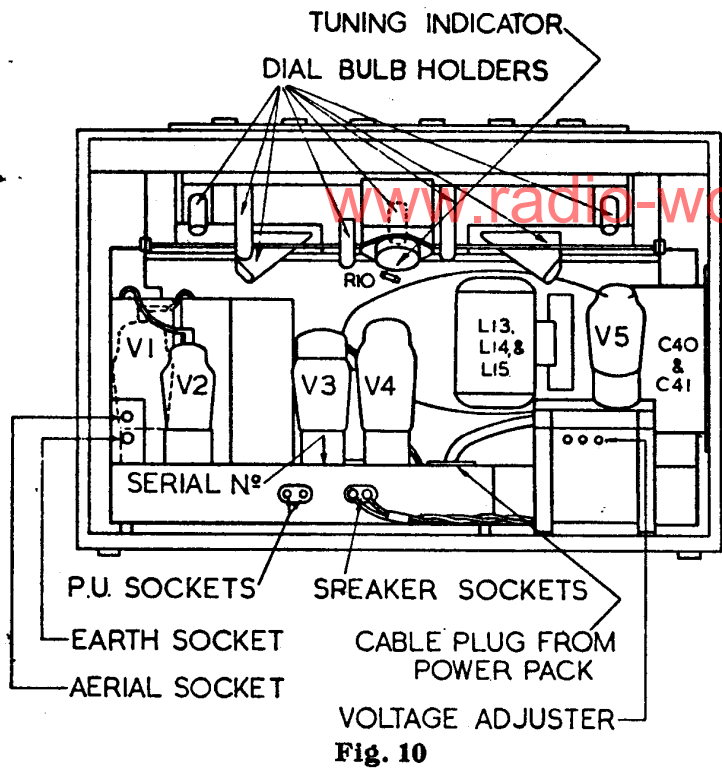

Fig. 10

## Removing the Chassis from the Cabinet.

To remove the chassis lay the cabinet face downwards and disconnect L.S. speech coil plugs. Then disconnect L.S. field by removing first of all the rectifier valve and then the three screws securing leads to L.S. panel.

The L.S. earth lead should then be removed. This lead is connected to the mains transformer by means of a 4 BA nut.

The three 4 BA nuts and bolts securing the mains transformer to the bottom of the cabinet must be removed and then the transformer can be removed after the power plug has been withdrawn from the chassis.

Next the condenser block which is secured to the side of the cabinet by two wood screws must be removed.

Now loosen the two round head screws holding dial bracket to sloping portion of the cabinet. (N.B. These need not be removed from rubber bushes simply loosen until dial is free from cabinet.) Next remove the 4 chassis bolts from the underside of cabinet then turn

cabinet right way up and remove the four control knobs by means of a direct forward pull.

The chassis can then be withdrawn by tilting towards front of cabinet so that the dial clears the top of cabinet. There are three speaker connections and they are connected as follows :

### Top terminal.

Black lead to condenser block.  
Black lead to mains transformer earthing bolt.

### Central terminal.

Lead to C40 (16 MFD).  
Yellow lead to mains transformer.

### Bottom terminal

Black lead to mains transformer.  
Lead to C41 (8MFD).

## Servicing the Chassis when out of the Cabinet.

When operating the receiver out of the cabinet it is important that the loudspeaker, electrolytic condenser and mains transformer be connected as above, and the multi cable plugged into the holder on the chassis.

When the chassis has been removed from the cabinet, care must be taken when making adjustments to the underside, that the valves and the more delicate mechanism are not crushed.

If a considerable amount of work is to be carried out on the chassis such as removing the coils, gang condenser or transformer the chassis should be mounted on a suitable stand, such as the "Pye Chassis Cradle." (Use the standard fixing bolts when securing chassis on the Pye Chassis Cradle).

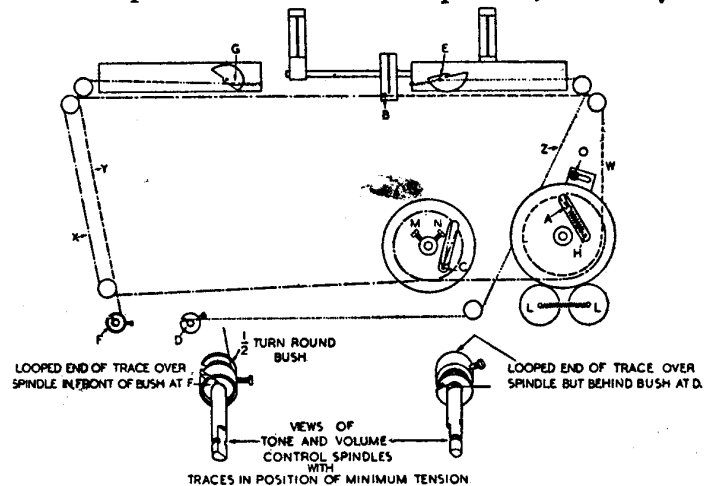

Fig. 12

## Dial and Tuning Indicator Bulb Replacements.

If it becomes necessary to renew one or more of the eight bulbs illuminating the dial, switch off the set and remove the back of the receiver. Looking from the back you will see the ends of seven bulb holders and the bulb illuminating the "Gram" index is situated behind the Tuning Indicator bracket. The holder containing the faulty bulb may be removed by easing it out of its socket by a slight pull. The correct replacements are Ever Ready 6.2 volt .3 amp. bulbs. All the bulbs are sprayed with green paint with exception of the two general illumination bulbs situated at each end of the scale.

If it becomes necessary to replace the Tuning Indicator it can be removed by unscrewing the two hexagon fixing nuts which hold it in position. The correct replacement is an Ever Ready A39A Tuning Indicator.

'TRADER' SERVICE SHEET

228

## PYE QAC 3

3-BAND A.C. SUPERHET

**T**HE Pye QAC3 is a 4-valve (plus rectifier) A.C. 3-band superhet covering a short-wave range of 15.5-52.5 metres, and having provision for a gramophone pick-up and an extension speaker, while the internal speaker can be cut out if desired. A feature of the set is the inclusion of a cathode-ray tuning indicator, and the special scale with luminous indications.

In its standard form the receiver is suitable for mains of 200-250 V, 40-100 C/S, and one of these was used for preparing this *Service Sheet*, but there are other models catering for 100 V and 25 C/S supplies.

## CIRCUIT DESCRIPTION

Aerial input via **L3** (M.W. and L.W.) and **L2** (S.W.) to single-tuned circuits **L4**, **C33** (S.W.), **L5**, **C33** (M.W.) and **L6**, **C33** (L.W.). I.F. filter **L1**, **C30** is connected across **L3**.

First valve (**V1**, Ever Ready metallised **A36A**) is a triode-hexode operating as frequency changer with internal coupling. Oscillator grid coils **L7** (S.W.), **L8** (M.W.) and **L9** (L.W.) are tuned by **C34**; parallel trimming by **C35** (M.W.) and **C8** (L.W.); series tracking by **C7**, **C36** (M.W.), **C37** (L.W.) and **C9**. Anode reaction coils **L10** (S.W.) and **L11** (M.W. and L.W.).

Second valve (**V2**, Ever Ready metallised **A50P**) is a variable- $\mu$  R.F. pentode operating as intermediate frequency amplifier with tuned-primary tuned-secondary transformer couplings **C38**, **L12**, **L13**, **C39** and **C40**, **L14**, **L15**, **C41**.

Intermediate frequency 465 KC/S.

Diode second detector is part of double-

diode triode valve (**V3**, Ever Ready metallised **A23A**). Audio frequency component in rectified output is developed across load resistance **R12** and passed via A.F. coupling condenser **C16**, I.F. stopper **R13** and manual volume control **R14** to C.G. of triode section. Cathode ray tuning indicator (**T.I.**, Ever Ready **A39A**) is operated by potential tapped off potentiometer **R9**, **R10** which is connected across signal diode load resistance **R12**. Provision for connection of gramophone pick-up across **R14** via **S9**; **S7** closes on gram. to mute radio. **S3** closes across pick-up sockets on L.W. only.

Resistance-capacity coupling by **R17**, **C21** and **R19** between **V3** triode and pentode output valve (**V4**, Ever Ready **A70D**). Fixed tone correction in anode circuit by **C26**; four-position variable tone control by **S10**, **S11**, **S12** in connection with R.C. filter **R20**, **C23** and **C24**. Heterodyne filter **L16**, **C25** is connected in anode circuit. Provision for connection of low impedance external speaker across secondary of **T1** by means of the socketed plugs used for connection of internal speaker speech coil; these can be withdrawn, thus muting the internal speaker.

H.T. current is supplied by I.H.C. full-wave rectifying valve (**V5**, Ever Ready **A11D**). Smoothing by speaker field coil **L19** and dry electrolytic condensers **C28** and **C29**. R.F. filtering by **C5**.

## DISMANTLING THE SET

A detachable bottom is fitted to the cabinet and upon removal (four round-head wood screws) gives access to most

of the components under the receiver chassis.

**Removing Chassis.**—If it should be necessary to remove the chassis from the cabinet, remove the four control knobs (pull off) and unplug the speaker speech coil leads from the sockets at the back of the chassis and the power supply connector from the valve-holder on the chassis.

Now disconnect the leads from the mains transformer to the speaker terminal panel (screw terminals) and remove the electrolytic condenser block from the side of the cabinet (two round-head wood screws). Next remove the earthing lead from one of the mains transformer bolts.

Remove the three screws (with nuts, washers and spring washers) holding the mains transformer to the bottom of the cabinet and remove it from the cabinet. Remove the four bolts (with washers) holding the chassis to the bottom of the cabinet and loosen the two round-head wood screws (with washers) holding the scale assembly to the top of the cabinet. These screws need not be removed.

The chassis can now be withdrawn by tilting the back upwards.

**When replacing**, connect the leads to the speaker as follows, numbering the terminals from bottom to top:—1, black; 2, yellow. Do not forget to replace on the right-hand transformer fixing screw the cleat which holds the speaker speech coil and earthing leads.

**Removing Speaker.**—To remove the speaker from the cabinet, disconnect the leads and remove the four screws holding it to the sub-baffle. *When replacing*, see

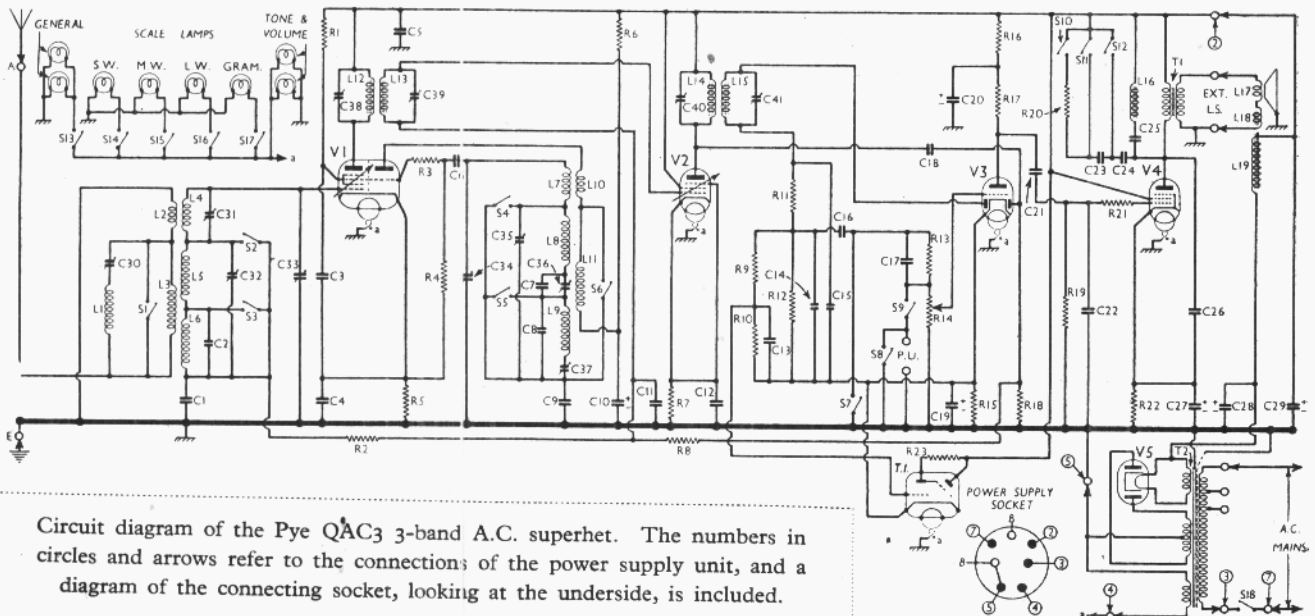

Circuit diagram of the Pye QAC3 3-band A.C. superhet. The numbers in circles and arrows refer to the connections of the power supply unit, and a diagram of the connecting socket, looking at the underside, is included.

Under-chassis view. The wave-change and gramophone switches are identified, as are also the tone control switches on the left. A separate diagram of the scale lamp switch unit is on page VIII.

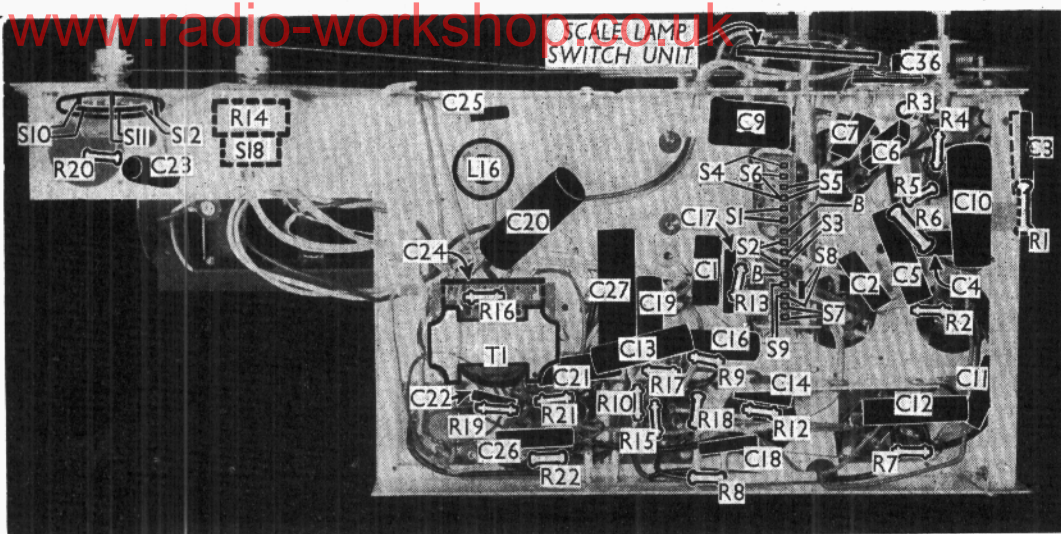

that the terminal panel is on the right and connect the leads from the mains transformer as above and the leads from the electrolytic block as follows:— 1, yellow; 2, brown; 3, black.

**COMPONENTS AND VALUES**

RESISTANCES		Values (ohms)
R1	V1 S.G. H.T. feed ..	80,000
R2	V1 hex. C.G. decoupling ..	110,000
R3	V1 osc. grid circuit stabiliser ..	50
R4	V1 osc. C.G. resistance ..	25,000
R5	V1 fixed G.B. resistance ..	200
R6	V1 osc. anode H.T. feed ..	80,000
R7	V2 fixed G.B. resistance ..	300
R8	A.V.C. line decoupling ..	1,100,000
R9	T.I. C.G. potentiometer ..	2,100,000
R10	I.F. stopper ..	510,000
R11	V3 signal diode load ..	110,000
R12	I.F. stopper ..	510,000
R13	Manual volume control ..	500,000
R14	V3 G.B. resistance ..	1,000
R15	V3 triode anode decoupling ..	25,000
R16	V3 triode anode load ..	110,000
R17	V3 A.V.C. diode load ..	1,100,000
R18	V4 C.G. resistance ..	260,000
R19	Part of variable T.C. filter ..	20,000
R20	V4 C.G. I.F. stopper ..	25,000
R21	V4 G.B. resistance ..	150
R22	T.I. anode H.T. feed ..	2,100,000

CONDENSERS		Values (µF)
C1	V1 hex. C.G. decoupling ..	0.05
C2	Aerial circuit L.W. trimmer ..	0.00001
C3	V1 S.G. decoupling ..	0.1
C4	V1 cathode by-pass ..	0.1
C5	H.T. positive R.F. by-pass ..	0.1
C6	V1 oscillator C.G. condenser ..	0.0001
C7	Osc. circuit M.W. fixed trimmer ..	0.00005
C8	Osc. circuit L.W. fixed trimmer ..	0.00002
C9	Fixed tracker ..	0.005
C10*	V1 osc. anode decoupling ..	2.0
C11	V2 C.G. decoupling ..	0.05
C12	V2 cathode by-pass ..	0.1
C13	T.I. feed decoupling ..	0.1
C14	I.F. by-passes ..	0.00005
C15	A.F. coupling to V3 triode ..	0.01
C16	I.F. by-pass ..	0.0002
C17	Coupling to V3 A.V.C. diode ..	0.0001
C18	V3 cathode by-pass ..	20.0
C19*	V3 triode anode decoupling ..	2.0
C20*	V3 triode to V4 A.F. coupling ..	0.025
C21	V4 C.G. I.F. by-pass ..	0.0005
C22	Parts of variable T.C. filter ..	0.025
C23	Part of heterodyne filter ..	0.002
C24	V4 anode fixed tone corrector ..	0.001
C25	V4 cathode by-pass ..	50.0
C26*	H.T. smoothing ..	8.0
C27*		16.0
C28*		
C29*		

CONDENSERS (Continued)		Values (µF)
C30†	Aerial circuit I.F. filter tuning ..	—
C31†	Aerial circuit S.W. trimmer ..	—
C32†	Aerial circuit M.W. trimmer ..	—
C33†	Oscillator circuit tuning ..	—
C34†	Oscillator circuit M.W. trimmer ..	—
C35†	Oscillator circuit M.W. tracker ..	—
C36†	Oscillator circuit L.W. tracker ..	—
C37†	1st I.F. trans. pri. tuning ..	—
C38†	1st I.F. trans. sec. tuning ..	—
C39†	2nd I.F. trans. pri. tuning ..	—
C40†	2nd I.F. trans. sec. tuning ..	—

\* Electrolytic. † Variable. ‡ Pre-set.

OTHER COMPONENTS		Approx. Values (ohms)
L1	Aerial I.F. filter coil ..	11.0
L2	Aerial S.W. coupling ..	0.5
L3	Aerial M.W. and L.W. coupling ..	130.0
L4	Aerial S.W. tuning coil ..	Very low
L5	Aerial M.W. tuning coil ..	2.8
L6	Aerial L.W. tuning coil ..	11.2
L7	Oscillator S.W. tuning coil ..	Very low
L8	Oscillator M.W. tuning coil ..	1.8
L9	Oscillator L.W. tuning coil ..	4.5
L10	Oscillator anode S.W. reaction ..	33.0
L11	Oscillator anode M.W. and L.W. reaction ..	8.0
L12	1st I.F. trans. Pri. ..	5.0
L13	1st I.F. trans. Sec. ..	5.0
L14	2nd I.F. trans. Pri. ..	5.0
L15	2nd I.F. trans. Sec. ..	5.0
L16	Heterodyne filter choke ..	44.0
L17	Speaker speech coil ..	1.8
L18	Hum neutralising coil ..	0.25
L19	Speaker field coil ..	1,800.0
T1	Output transformer { Pri. ... 700.0 Sec. ... 0.3	
T2	Mains trans. { Pri. total .. 22.6 Heater sec. .. 0.2 Rect. heat. sec. .. 0.2 H.T. sec. total .. 778.0	
T.I.	Cathode ray tuning indicator ..	—
S1-S6	Waveband switches ..	—
S7-S9	Radio-gram change switches ..	—
S10-12	Tone control switches ..	—
S13-17	Scale lamp switches ..	—
S18	Mains switch, ganged R14 ..	—

**VALVE ANALYSIS**

Valve voltages and currents given in the table (col. 3) are those measured in our receiver when it was operating on mains of 235 V, using the 216-235 V tapping on the mains transformer. The receiver was tuned to the lowest wavelength on the medium band and the volume control was at maximum, but there was no signal input.

Voltages were measured on the 1,200 V scale of an Avometer, chassis being negative.

Valve	Anode Voltage (V)	Anode Current (mA)	Screen Voltage (V)	Screen Current (mA)
V1 A36A	250	1.6	40	2.9
V2 A50P	250	10.1	250	3.6
V3 A23A	80	1.3	—	—
V4 A70D	210	42.0	250	6.9
V5 A11D	360	—	—	—

Oscillator anode 55 V, 2.5 mA. Each anode, A.C.

**GENERAL NOTES**

**Switches.**—S1-S9 are the waveband and gramophone switches, in a ganged unit beneath the chassis. All these switches are indicated in our under-chassis view. The table below gives the switch positions for the four control settings, starting from fully anti-clockwise. O indicates open, and C closed.

Switch	S.W.	M.W.	L.W.	Gram.
S1	C	O	O	O
S2	C	O	O	O
S3	C	O	O	O
S4	C	O	O	C
S5	C	O	O	C
S6	O	O	O	C
S7	O	O	C	O
S8	O	O	O	C
S9	O	O	O	C

Note that S8 consists of one fixed contact in the bank and a moving metal contact rivetted to the rotor spindle, and hence connecting to chassis.

S10-S12 are the tone control switches in a separate rotary unit, all the contacts being indicated in our under-chassis view. Five of the fixed contacts are blank, and three are used. In the fully anti-clockwise position S12 is closed, in the next position S11 is closed, in the third position S10 is closed, and in the fourth position all the switches are open.

S13-S17 are the scale lamp switches, in a rotary unit in front of the chassis, ganged with the wavechange and gram. unit. S13 controls the general lighting, and S14, S15, S16 and S17 the S.W., M.W., L.W. and gram. scale indicators respectively. A diagram of the switch

Continued overleaf

www.radio-workshop.co.uk

**PYE QAC3—Continued**

unit is given below, indicating the switches as seen from the front of the chassis, when it is standing on its base. The table below gives the switch positions for the four control settings, starting from fully anti-clockwise. O indicates open, and C closed.

The tone and volume indicator lamps are always on when the set is operating.

Switch	S.W.	M.W.	L.W.	Gram.
SI3	C	C	C	O
SI4	C	O	O	O
SI5	O	C	O	O
SI6	O	O	C	O
SI7	O	O	O	C

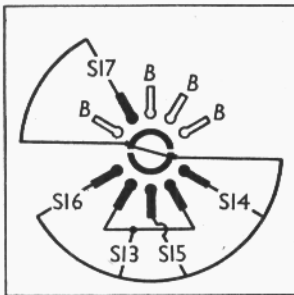

The scale lamp switch unit, looking from the front of the chassis when it is standing on its base.

**SI8** is the Q.M.B. mains switch, ganged with the volume control **R14**.

**Scale Lamps.**—There are eight of these in all, all Ever-Ready M.E.S. types, rated at 6.2 V, 0.3 A, and having small bulbs. All the lamps are sprayed green, except the two used for general illumination, which are clear. The lamps are controlled by five switches, dealt with above.

**Coils.**—**L1** is behind the **A, E** brackets

mounted on the chassis. **L2-L6, L7-L11** and the I.F. units **L12, L13** and **L14, L15**, are in four screened units on the chassis deck. Apart from the associated trimmers (two in each unit), the **L7-L11** unit also contains **C8**, and the **L14, L15** unit contains **R11** and **C15**. The choke **L16** is beneath the chassis.

**Condensers C28, C29.**—These are two dry electrolytics in a single carton fixed to the right-hand side of the cabinet. There is a common negative (black) lead, the yellow lead is the positive of **C28** (8 $\mu$ F) and the red the positive of **C29** (16 $\mu$ F).

**Power Unit.**—The mains transformer and rectifier valve are in a unit fitted to the bottom of the cabinet. It is connected to the chassis by a 6-pin plug and socket. Actually a standard 7-pin valve plug and socket is used, with pin 1 removed and pin 6 blank. Sockets 1 and 6 on the holder are both blank, but 5 and 6 are joined by a wire. The numbering, looking at the underside of the socket, is indicated on the sketch of the socket inset in the circuit diagram. The coding of the wires to the plug is: Pin 2, yellow; pin 3, blue; pin 4, red; pin 5, black; pin 6, blank; pin 7, green.

**Tuning Indicator.**—The tuning indicator and its holder may be removed by undoing the two hexagonal-headed screws holding them in position. An 8 side-contact base is fitted, and the connections are given in the diagram on this page.

**Chassis Divergencies.**—**C2** in our chassis was not in the **L2-L6** coil unit as indicated by the makers, but was under this unit, beneath the chassis. **C26** was connected from anode of **V4** to chassis, not across the primary of **T1**.

**External Speaker.**—The internal speaker is connected to the sockets at the rear of the chassis by the usual socketed plugs, and a low resistance (1.5-2.5 O) external speaker can thus be used alone, or in parallel with the internal speaker.

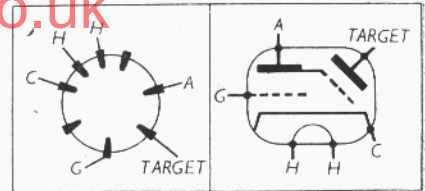

Base connections and diagram of the cathode ray tuning indicator used.

**CIRCUIT ALIGNMENT**

When the gang is fully in mesh the cursor should be on the setting mark at the top end of the M.W. scale (beyond the 550 m. mark).

**I.F. Stages.**—Feed in a 465 KC/S signal to control grid (top cap) of **V1** via a 0.002  $\mu$ F condenser, and chassis, first removing the existing lead to the control grid, and connecting a 0.5 MO resistance between control grid and chassis. Also connect a 0.25  $\mu$ F condenser between oscillator anode of **V1** and chassis. Adjust **C41, C40, C39** and **C38** in that order for maximum output. Remove the swamp condenser and the 0.5 MO resistance, and replace top cap connection of **V1**.

**R.F. and Oscillator Stages.**—Switch set to S.W., tune to 15 MC/S on scale, feed a 15 MC/S (20 m.) signal into **A** and **E** sockets, and adjust **C31** for maximum output.

Switch set to M.W., tune to 210 m. on scale, feed in a 210 m. (1,428 KC/S) signal via a dummy aerial, and adjust **C35**, then **C32**, for maximum output. Tune to 520 m. on scale, feed in a 520 m. (577 KC/S) signal, and adjust **C36** (front of chassis) for maximum output, whilst rocking the gang for optimum results. Re-check at 210 m.

Switch set to L.W., tune to 1,800 m. on scale and feed in an 1,800 m. (166.5 KC/S) signal. Adjust **C37** for maximum output whilst rocking the gang.

**I.F. Filter.**—Feed in a 465 KC/S signal, and adjust **C30** for minimum output.

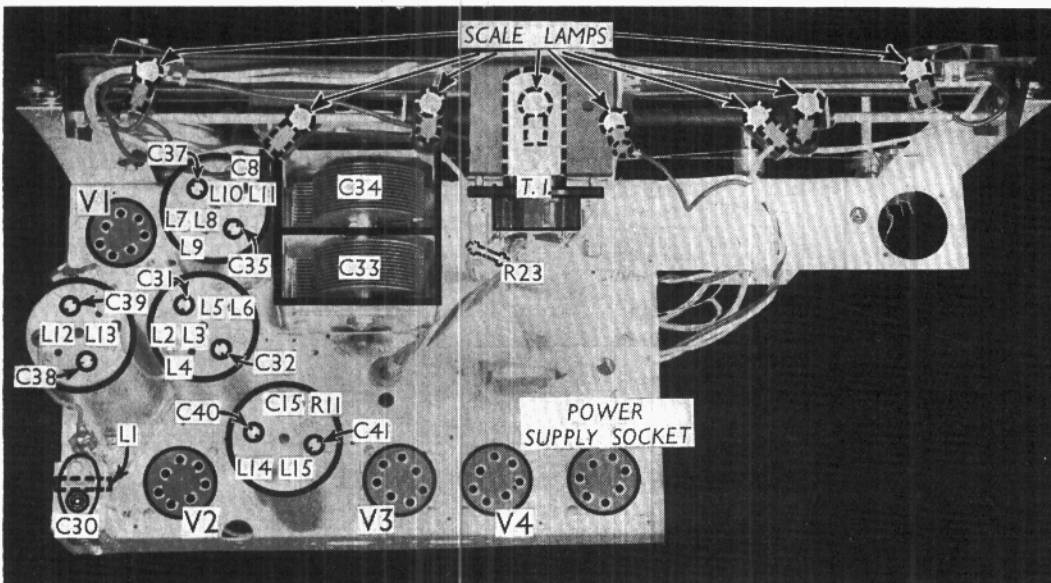

Plan view of the chassis. Note the eight scale lamps used for various indicating purposes. **C8** is inside the **L7-L11** coil unit, and **R11** and **C15** inside the **L14, L15** unit.