

BEETHOVEN A1188

Nine-valve, eleven-waveband superhet with RF stage with Ten SW ranges, all of which are band-spread, and with push-pull output stage. Sockets for crystal or magnetic pickup and low-impedance extension loudspeaker. Figured walnut table-type cabiner. For 100 to 250V 40-100 c/s AC. Manufactured by Beethoven Electric Equipment, Ltd., Chapel Lane, Sands, High Wycombe, Bucks.

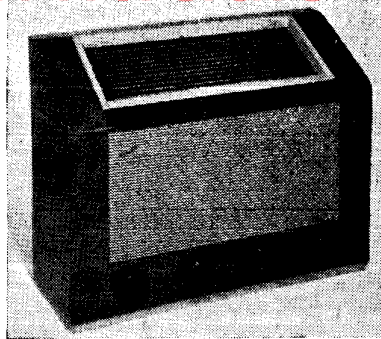

AERIAL is fed to S2 and thence to coupling coils L1, L3, etc. The SW grid coils L2, L4, etc., are switched by S1 to g1 of RF amplifier V1. The MW coil L22 is capacitively coupled by C1, C15 to L33 in a bandpass circuit in the grid of frequency changer V2. S4 switches the tuning capacitor VC1 through series capacitors C4, C5, C6, C7 and C8 to S3, and thence to g1 of V1, except on MW band when it is switched direct to L22. In SW1 position of S4 capacitor C9 is in parallel with VC1. In all except SW1 position C3 is connected in parallel with VC1. C10 is shunted between g1 and earth. R36 is grid resistor. Cathode bias is provided by R3 decoupled by C11 with C12 to give decoupling at the highest frequencies.

HT for V1 anode, decoupled by R2, C16, C17, is fed through tuned coils L23-L32. S5 switches the anode to the coils and S7 switches tuning capacitor VC2, through series capacitor C20, C21, C22, C23, C26 to S8, and thence to the coils. In SW1 position of S7, capacitor C24 is paralleled with VC2. C18 is connected across VC2 except on MW. C25 is coupled between anode V1 and chassis. On MW band, however, VC2 is switched direct to bandpass coil L33.

Frequency-changer. On SW bands signal from V1 anode is coupled by C27 to S6 and thence to g1 of frequency-changer V2. On MW band the signal from the aerial bandpass circuit is coupled by C19 to V2. T1, (Continued opposite)

L	Ohms
54	...
55	...
56	Very Low
57	...
58	...
59	...
60	...
61	80J Total
62	...
63	...
64	Very Low
65	130 Total
66	Very Low
67	...
68	9.5 Total

CAPACITORS

C	Capacity	Type
1	.02 Tubular 350V	
2	5pF Twisted Wire	
3	400pF Silver Mica	
4	375pF Silver Mica	
5	200pF Silver Mica	
6	110pF Silver Mica	
7	70pF Silver Mica	
8	50pF Silver Mica	
9	200pF Silver Mica	
10	10pF Tubular Ceramic	
11	.1 Tubular 350V	
12	.005 Mica	
13	.1 Tubular 350V	
14	100pF Mica	
15	1pF Twisted Wire	
16	.01 Tubular 350V	
17	.01 Tubular 350V	
18	400pF Silver Mica	
19	100pF Silver Mica	
20	375pF Silver Mica	
21	200pF Silver Mica	
22	110pF Silver Mica	
23	70pF Silver Mica	
24	200pF Silver Mica	
25	10pF Ceramic	
26	50pF Silver Mica	
27	100pF Silver Mica	
28	100pF Silver Mica	
29	100pF Silver Mica	
30	100pF Silver Mica	
31	100pF Silver Mica	
32	10pF Ceramic	
33	50pF Silver Mica	
34	200pF Silver Mica	
35	70pF Silver Mica	
36	100pF Silver Mica	
37	180pF Silver Mica	
38	.1 Tubular 350V	
39	100pF Silver Mica	
40	.1 Tubular 350V	
41	170pF Silver Mica	
42	300pF Silver Mica	
43	555pF Silver Mica	
44	400pF Silver Mica	
45	.1 Tubular 350V	
46	.1 Tubular 350V	
47	.1 Tubular 350V	
48	10pF Ceramic	
49	100pF Silver Mica	
50	200pF Silver Mica	
51	.1 Tubular 350V	
52	.00025 Tubular 350V	
53	.01 Tubular 350V	
54	.005 Tubular 350V	
55	.002 Tubular 350V	
56	.001 Tubular 350V	
57	100pF Mica	
58	100pF Mica	
59	.01 Tubular 350V	
60	.005 Tubular 350V	
61	.002 Tubular 1000V	
62	.002 Tubular 1000V	
63	.05 Tubular 350V	
64	25 Electrolytic 25V	
65	3 Electrolytic 350V	
66	16 Electrolytic 350V	
67	16 Electrolytic 450V	
68	16 Electrolytic 450V	

RESISTORS

R	Ohms	Watts
1	1K	...
2	180	...
3	180	...
4	33K	...
5	1M	...
6	47K	...
7	220	...
8	47K	...
9	33K	...
10	100K	...
11	270	...
12	1M	...
13	1M	...
14	2M	...
15	47K	...
16	47K	...
17	47K	...
18	680	...
19	1M	...
20	1M	...
21	1M	...
22	1M	...
23	1M	...
24	250K	...
25	33K	...
26	1K	...
27	33K	...
28	250K	...
29	10K	...
30	47K	...
31	47K	...
32	100	...
33	100	...
34	1.2K	...
35	140	...
36	1M	...

INDUCTORS

L	Ohms
1	...
2-20	Very Low
21	12.5
22	3.0
23-32	Very Low
33	3.0
34	7.5
35	7.5
36-53	Very Low

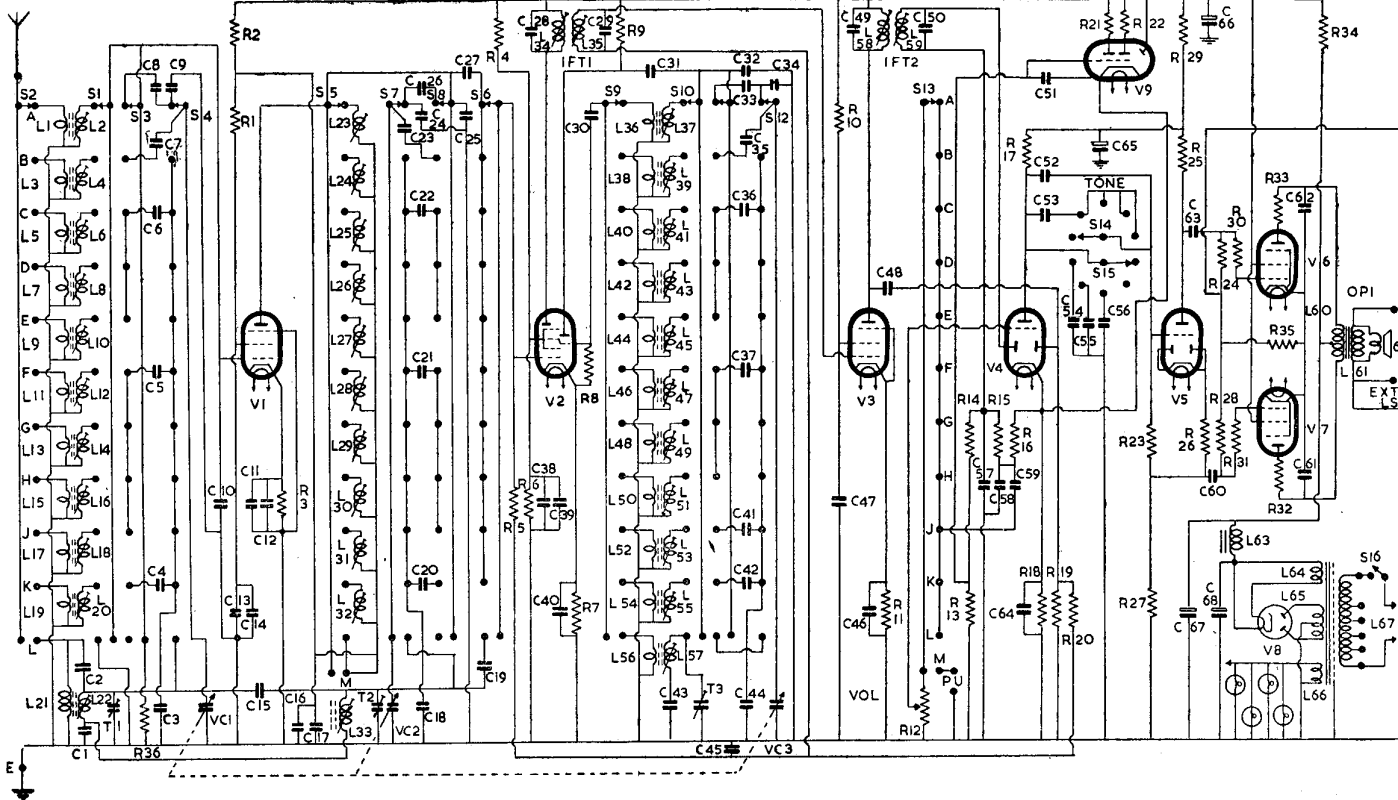
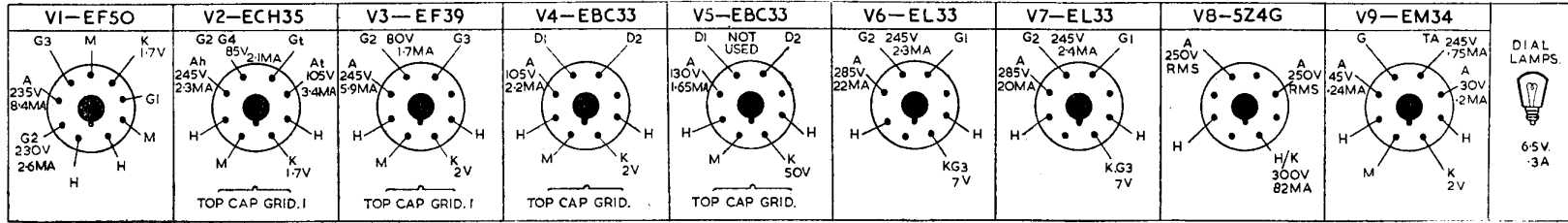

BEETHOVEN AII88

T2 are MW bandpass trimmers. AVC, decoupled by R20, C45, is applied through R5.

Oscillator is connected in a shunt-fed tuned-anode circuit. The anode coils L37, L39, etc., are switched by S10, through C31, to oscillator anode, of which R9 is the load. The MW coil L57 is provided with trimmer T3 and padder C43. The oscillator tuning capacitor VC3 is switched by S12 through series capacitors C33, C35, C37, C41, C42 to S11 and thence to the coils. On SW1 band C34 is shunted across VC3, whilst C32 is placed across the tuned circuit on all ranges. For the SW bands other than SW1, C44 is placed across VC3.

The grid reaction coils L36, L38, etc., are switched by S9 through C30 to oscillator grid of V2. Automatic bias for grid is developed on C30 with R8 as leak.

IF amplifier operates at 465 kc/s. Secondary L35, C29 of IFT1 feeds signal and AVC voltages, decoupled by R20, C45 to g1 of IF amplifier V3. Cathode bias is provided by R11 and decoupled by C46. Screen (g2) voltage is obtained from R10 and decoupled by C47. Suppressor grid (g3) is strapped to cathode. L58, C49, which form the primary of IFT2, are in the anode circuit.

Signal rectifier. Secondary L59, C50 of IFT2 feeds signal to one diode of V4. R16 is load, and R15, C57, C58 form an IF filter.

Tuning indicator. The DC component of the rectified signal is tapped from potential divider R13, R14 and fed to C51 and grid of tuning indicator V9. Cathode is coupled to cathode of V4. R21, R22 are anode load resistors. Target anode voltage is taken from HT line.

AVC. C48 feeds signal from primary of IFT2 to second diode of V4. R19 is its load. AVC voltages decoupled by R20, C45 are fed to control grids of V2 and V3. Cathode voltage of V4 provides a delay bias for the AVC diode.

Continued on page 48

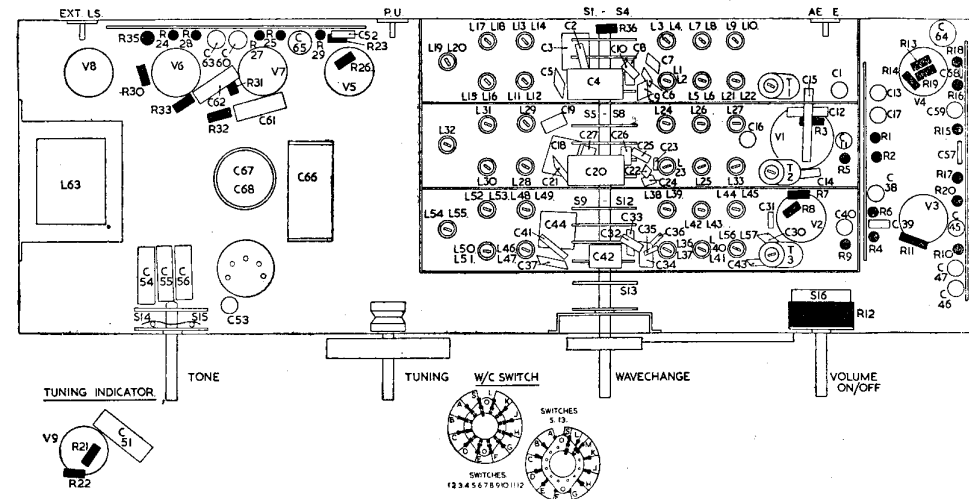

WAFERS AS SEEN FROM INVERTED REAR VIEW OF CHASSIS

TRIMMING INSTRUCTIONS

Apply Signal as Stated Below	Tune Receiver to	Trim in Order Stated for Max. Output
(1) 465 kc/s to fixed plates of VC2 via .01	MW 530 metres	Core L59, L58, L35, L34
(2) 600 kc/s to AE socket via dummy aerial	500 Metres	Core L57, L33, L22
(3) 1.4 mc/s as above	214 metres	T3, T2, T1 and repeat (2) and (3).
(4) SW Bands		

Alignment of the bandspeed ranges should be effected with great care as the normal signal generator is not accurate enough for satisfactory adjustment. Alignment in the factory is effected with crystal controlled apparatus. Should any adjustment be necessary, the receiver should be tuned to a station of known frequency and the oscillator, HF and aerial inductances adjusted in that order for max. output.

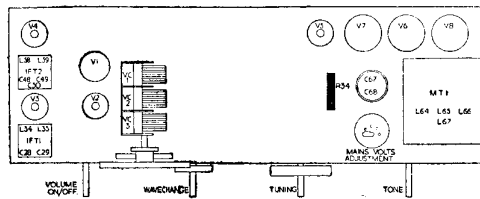
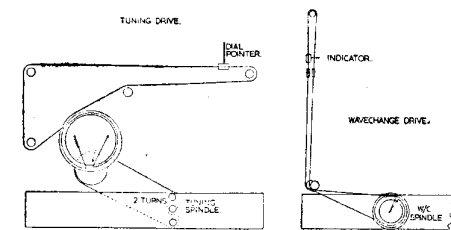

GARRARD RC70 AUTO-CHANGER

from page 43

Fig. 4.—Details of the pick-up control gear, centre spindle and record platform

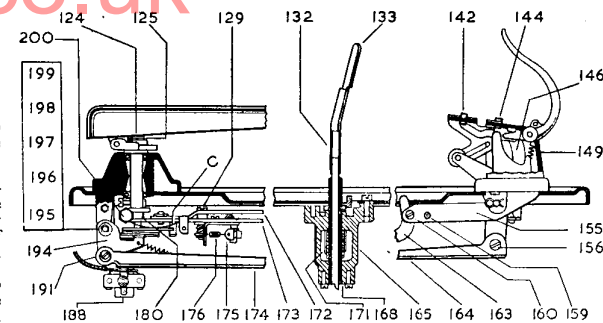

neath, unscrew the nuts on the three suspension screws, which secure the motor to the unit plate. Before drawing the motor away from the unit plate, note the sequence of steel and rubber washers on each suspension screw.

Pick-up Dropping Position. The pick-up arm has been finely adjusted so that the needle comes on to 10-in. records in a 9 3/8-in. diameter circle and 12-in. records in a 11 3/8-in. diameter circle. Should the position require adjustment, the pick-up adjusting screw—accessible through a hole in the unit plate (A and 129)—should be turned with the changer in its start position, that is, with the pick-up arm on its rest. A quarter of a turn in either direction gives maximum adjustment.

Should pick-up arm have been forced out of position and the adjustment provided by the screw be insufficient, operate the changer and allow it to switch off automatically, when the pick-up arm will be locked on or near the rest. Loosen the hexagonal headed screw 200 (do not attempt to turn the nut)—when the pick-up arm will be free, place arm centrally on rest and retighten the screw. Pick-up should now be in the correct position and any fine adjustment can be made with pick-up adjusting screw.

Pick-up Height can be adjusted by loosening the nut securing the eccentric 191 and adjusting the eccentric pivot with screwdriver in slot at back. Finally, retighten locking nut.

Caution. When making adjustments to the pick-up arm it should never be forced into position. If the turntable is turned by hand it should not be turned backward.

If the pick-up does not run into the record grooves after alighting on the record edge, see that the record changer is level by placing a spirit level on a record on the turntable. Make sure that the flexible wire leading to the pick-up is not twisted or held in such a manner as to prevent the free movement of the pick-up arm; also see that the associated levers are free.

Auto-trip Mechanism is set to operate when the needle reaches a 1 3/8-in. radius, or if it oscillates in an eccentric groove. Occasionally records having a smaller or larger radius at the end of the playing grooves are encountered. If it is desired to adjust the mechanism to take these exceptional records the screw B, visible through hole in unit plate, should be adjusted.

To make the trip operate earlier for larger radius records loosen the screw, and holding pick-up arm steady, move screw in slot a shade towards turntable. The screw should be moved a barely visible amount at each adjustment.

If an early model in which the pawl pivot 111 is missing and the pawl pivot is attached directly to the pick-up lever 173 has a tendency to trip prematurely on records that are eccentric (swingers), carefully polish corner of impulse lever 43 that engages on catch in trip lever 106 and strengthen slightly spring 105. Also stretch pawl spring 176 to weaken it.

Record Platform Adjustment. To set the platform, the nut 156 locking the eccentric should be loosened, and with mechanism set for 12-in. records pick-up arm in the playing position, and the largest 12-in. record available loaded on platform, turn the "eccentric adjustment" until there is a gap of not more than 1/8 in. between the edge of the record and the front edge of the platform pawl. Finally, retighten the locking nut 156.

Auto Stop at End of Last Record. When the last record on the platform drops on to the turntable it allows the record clip to fall and this unlocks the auto stop, which should switch off the motor at the end of the record. If, when the last record has been played, the record clip has fallen and the mechanism does not automatically stop, the following procedure should be carried out.

Locate swing lever 42 and knock-off extension 163. Note that in the upper edge of the knock-off extension there is a step. With the record clip lowered and the needle removed from the pick-up head, start the changer

with a hand on the turntable and slow it down to the slowest possible speed at which the mechanism will operate. Move the control lever to the "Reject" position. Swing lever 42 should now move outwards until it engages step on knock-off extension, and should remain engaged until record changer switches off. If swing lever does not engage step but passes over it, proceed as at (a) to correct. If it engages in step, set as at (b).

(a) Load two records on platform spindle in the usual way. Lower record clip and start changer. First record will now drop on to turntable, leaving one remaining on the platform. Again, with the hand operating as a brake to slow down turntable, move control lever to "Reject" position. The tip of the step on knock-off extension should now clear the surface of the swing lever in its outward movement by 1/64 in. If this dimension is incorrect, stop the changer when the swing lever is directly over step in knock-off extension. Knock-off extension is attached to knock-off lever 163 by rivet 159 and adjusting screw 160. Loosen the screw to adjust height of the extension until 1/64 in. clearance is obtained, then retighten screw. Finally, re-check changer with record clip lowered to ensure that swing lever engages step. Should auto top fail to operate, set as at (b) below.

(b) Loosen screws 89 and bring the two parts of the trip link 90 together to shorten slightly the effective length and retighten the screws. Check and repeat adjustment if necessary until changer operates correctly.

Pick-up slides across 10-in record and rejects without playing. This is due to the gap between swing lever and catch on knock-off extension being set too fine and the adjustment described at (a) above should be carried out.

Pick-up commences at varying distances. The fault can be due to two causes. Firstly, ascertain that the spring marked C is present in the changer. If spring is present the fault is probably due to pick-up arm lifting too high when it returns to the rest after playing a record, and to check this stop the motor when pick-up arm is halfway back towards the rest after 10 records have been played. In this position, with a 3/8-in. long needle in the pick-up, the tip of the needle should be just clearing the surface of top record.

If clearance is greater, it indicates the mechanism is lifting arm too high, and to correct it, loosen locking nut on back of eccentric pin 191 and turn pin by means of slot in the end opposite to nut until pick-up is at the correct height, then retighten nut.

If the spring mentioned above is not fitted it may be obtained from the Garrard Service and Spares factory.

Pick-up alights on record and immediately rises again, unit drops next record and repeats the process through all records on platform without playing any. When unit is in playing position, i.e. the needle being on the record, there should be a slight amount of play in lever 164 discernible as a movement between pin 49 and end of slot in lever 164. If no movement is present, slightly adjust eccentric pin 156 to produce it.

There should be a clearance between the end of reject lever 82 and trip lever 106. If not, gently bend reject lever 82 slightly away from trip lever 106.

Occasionally, due to either spring 105 being weak, or to trip lever 106 being sluggish on its pivot the impulse lever 43 does not engage catch inside trip lever, but moves back in to give the pin on the cam the impulse to recommence the changing cycle, in which case free trip lever and strengthen spring as necessary.