

PHILCO U2

Three valve, plus rectifier, single waveband midget superhet, with loop aerial and for 200-250 volts A.C. or D.C. operation. Made by Philco Radio and Television Corporation of G.B., Ltd., Perivale, Middlesex.

Circuit.—The loop aerial includes a primary section to which an aerial and earth can be connected and which is isolated from the chassis for safety by C13. This is a single band set and so the loop, which forms the grid coil, is

connected to V1 without any switching. V1 is the frequency changer. The oscillator section is tuned grid, and reaction is obtained by means of feedback provided by R5 and C5. The padding condenser T3 is common to both grid and anode circuits, and its reactance therefore introduces part of the anode signal into the grid circuit.

A trimmer-tuned I.F. transformer couples V1 to V2 in the usual way. V2 first acts as an I.F. amplifier in the usual way, the signal being passed on to the demodulation diode, also in V2, by means of a single-tuned I.F. transformer.

R17 with C14 and C15 form an I.F. filter. VR1 is the volume control, and the L.F. signal is taken via C4 and R7 back to the grid circuit of V2.

The amplified L.F. signal is developed in the anode circuit by R6 and passed by C10 to the grid of V3, the output pentode.

A.V.C. is taken from the signal diode of V2 (the other diode is not used) and passed back to both V2 and V1 in the usual way.

H.T. is obtained from either A.C. or D.C. mains of 200-250 volts, 40-100

cycles, without adjustment. V4 is a full-wave rectifier in a half-wave circuit, the D.C. output from the cathode being smoothed by the speaker field coil L9, with the electrolytics EC1-1 and EC1-2. The valve heaters are connected in series, and the mains voltage is "broken" down by R1, which is in the mains cord.

Notes.—Power consumption, 70 watts approximately. The pilot lamp is a 6.3 v., .3 amp. type, part No. 34-2141. There is no extension speaker connection. Voltages across the valve heaters are: V1 and V2, 6.3; V3, 14 and V4, 25.

Warning.—Remember the chassis may be live.

GANGING

The chassis must be in its normal position in relation to the frame aerial; it is best to carry out alignment with the chassis in the cabinet.

Open condenser to maximum. Insert a .006 in. feeler gauge under the heel of the moving vanes and adjust pointer so that it is horizontal at the bottom of the scale.

I.F. Circuits.—Inject 465 kc. to the grid of V1, and with generator earthed

to set earth socket. Adjust I.F. trimmers for maximum on output meter, keeping signal always below A.V.C. point.

Medium Waves.—Set pointer to 200 m. on scale. Inject 1,500 kc. to aerial and adjust T1 and T2.

Feed in and tune to 500 m. (600 kc.). Adjust T3 while rocking gang slightly. Readjust T1 at 200 m.

Repeat adjustments until no further improvement results.

VALVE READINGS

| V | Type | Electrode | Volts |
|---|------|-----------|----------|
| 1 | 6A7 | Anode | 190 |
| | | Screen | 75 |
| | | Bias | 3 |
| 2 | 6B7E | Anode | 90 |
| | | Screen | 75 |
| | | Bias | 3.75 |
| 3 | 18E | Anode | 185 |
| | | Screen | 190 |
| | | Bias | 14 |
| 4 | 25Z5 | Cathode | 255 D.C. |

WINDINGS

| L | Ohms. | L | Ohms. |
|---|-------|---|-------|
| 1 | 1 | 6 | 300 |
| 2 | .5 | 7 | .5 |
| 3 | 12 | 8 | 2.5 |
| 4 | 3 | 9 | 1,500 |
| 5 | 25 | | |

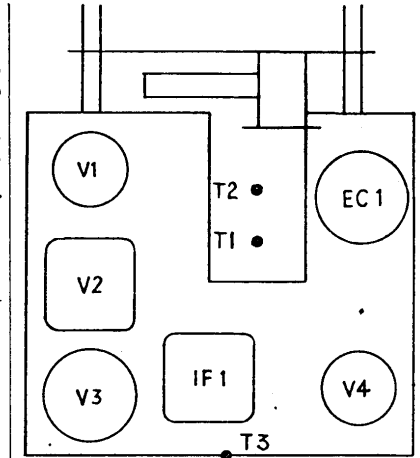

How components are arranged on the top of the chassis. It is a single waveband set with only three trimmers.

CONDENSERS

| C | Mfds. | C | Mfds. |
|---|-------------------|-------|------------|
| 1 | 30 mmfds. | 9 | .04 |
| 2 | .04 | 10 | .0065 |
| 3 | .025 | 11 | .001 |
| 4 | .0085 | 12 | .04 |
| 5 | .0065 | 13 | .025 |
| 6 | .04 | 14 | 100 mmfds. |
| 7 | 400 or 500 mmfds. | 15 | 100 mmfds. |
| 8 | .001 | E.C.1 | 8 + 16 |
| | | E.C.2 | 25 |

RESISTANCES

| R | Ohms. | R | Ohms. |
|---|----------------------------|-----|--------------------------|
| 1 | 580 | 10 | 1.5 meg or 1 meg. |
| 2 | 70 or 75 | 11 | 100,000 |
| 3 | 70 or 75 | 12 | 400 |
| 4 | 25,000 | 13 | 25,000 |
| 5 | 25,000 | 14 | 750 or 850 |
| 6 | 40,000 or 35,000 | 15 | 400,000 |
| 7 | 35,000 or 51,000 or 40,000 | 16 | 400 |
| 8 | 4 meg. or 5 meg. | 17 | 51,000, 60,000 or 65,000 |
| 9 | 2 meg. | VR1 | .5 meg. |

Midget Set's Fault

THE trouble with a midget was loud hum and crackle. A check of each stage indicated the trouble was in the I.F. stage. Having eliminated practically everything, the second I.F. transformer was replaced. The set returned to normal.

The resistance of the I.F. coil read O.K. So for our own satisfaction we roughly reconnected the transformer with the ohmmeter still across it. We found that when the set became really hot the primary showed an open circuit.

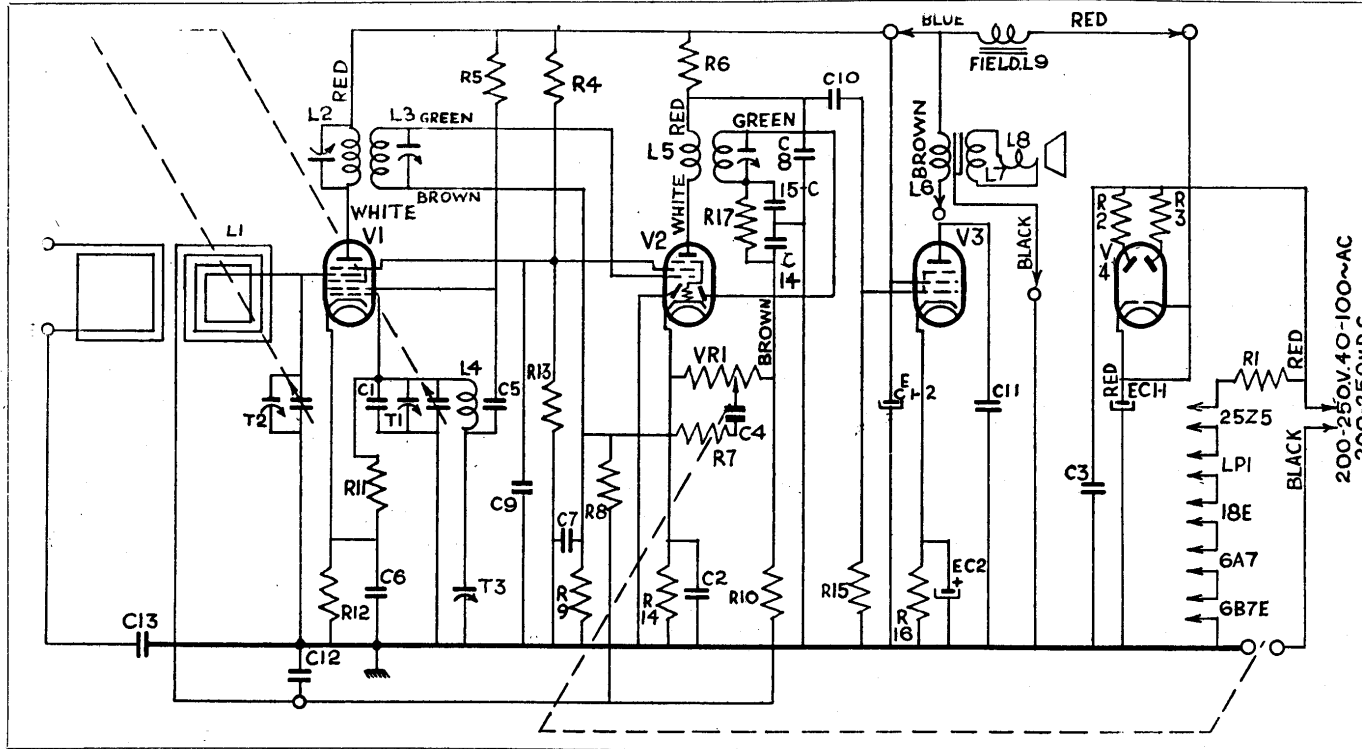

A feature is the reflex second valve. This acts first as an I.F. amplifier combined with a diode. The signal, as demodulated L.F., is then fed back through the valve a second time.