

**PHILCO
V537**

Four-valve, plus rectifier and barretter, three-waveband superhet for operation from AC or DC mains, 190-260 v, 40-100 cycles. Sockets for a pickup and extra loudspeaker are provided. Made by Philco Radio and Television Corporation of Great Britain, Ltd., Perivale, Greenford, Middlesex.

AERIAL input may be either via built-in coupling circuits for Philco all-wave noise reducing aerial, or—with link connections to "B"—by ordinary aerial and earth. The secondary coils L6 (LW) L8 (MW), L10 (SW) are tuned by VC2 section of the ganged condenser and feed the signal direct to the grid of the frequency changer V1. AVC is applied on all wavebands.

V1 is permanently biased by R2 decoupled by C12, and the oscillator section employs tuned grid circuits. Coupling

between the oscillator anode circuit and the grid circuits is effected by C14, which is common to both circuits, while additional coupling on SW is effected by L14 and C15.

The IF signal from V1 is coupled by the IF transformer L15, L16, to V2 the IF amplifier which is biased by R7 decoupled by C18 while a second IF transformer L17, L18, passes on the signal to the signal diode of the double diode triode V3.

The rectified LF signal is filtered by R8, C20 and C21, the load resistance being R9. From R9 the LF signal passes via C21a, to the volume control VR1, and thence to the triode section of V3.

AVC is derived from the signal passed from L18 via C24 to the AVC diode of V3, the AVC load resistance being R15. AVC is applied to V1 and V2 via decoupling components R14, C13, and R4.

A high impedance pickup input circuit is provided via the PU sockets and switch contacts to the "hot" end of the volume control VR1.

Resistance capacity coupling by R16, C26, R17 and R18 hand on the signal to the output pentode V4 which is cathode biased by R19 decoupled by C28. The output transformer L19, L20 couples V4 to the permanent magnet loudspeaker of which L21 is the speech coil.

Sockets for a very low impedance extra loudspeaker are provided in parallel with L21.

The heater circuits are all in series with the barretter across the mains input which is filtered by C30 while HT is derived from V5 connected as a half-wave rectifier with C29 reservoir condenser, L22 smoothing choke and C27 smoothing condenser.

GANGING

IF Circuits.—Switch receiver to MW with volume control at maximum. Inject a 451 kc signal to the grid cap of V1 (with grid lead connected) and adjust T1, T2, T3 and T4 for maximum output, keeping the signal input low to avoid AVC action.

Calibration Check.—With gang condenser fully open, check that indicator reads on index line. (Beyond 1,700 kc.)

LW Band.—Switch receiver to LW and

RESISTANCES

R	Ohms	R	Ohms
1	51,000	11	20,000
2	300	12	32,000
3	99,000	13	5,000
4	10,000	14	1 meg
5	25,000	15	1 meg
6	35,000	16	240,000
7	400	17	1 meg
8	51,000	18	120,000
9	330,000	19	500
10	3,000	VR1	2 meg

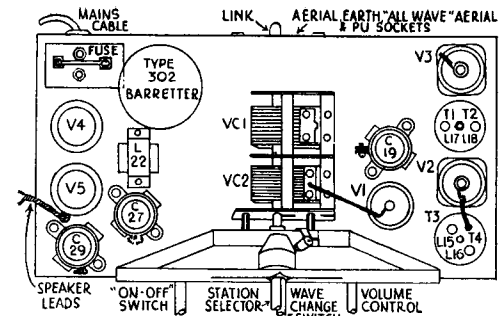
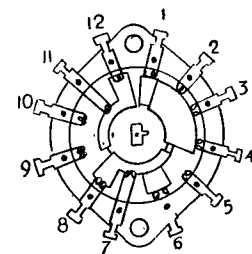

tune pointer to 290 kc. Inject a 290 kc signal via a dummy aerial to the aerial socket and trim T5 and T6 for maximum output.

Continued end column opposite page

WINDINGS

L	Ohms	L	Ohms
1	17.5	12	2.5
2	.5	13	.1
3	.5	14	Very low
4	2.5+2.5	15	8
5	16.5	16	12
6	25	17	12
7	.5	18+R17*	51,000 appx.
8	2.5	19	240
9	Very low	20	.2
10	.1	21	2
11	16.5	22	150

* R17 is inside IFT assembly.

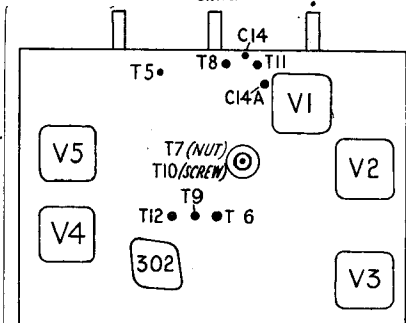

These diagrams identify the major components on the top of the Philco chassis and also show the positions of the trimmers. Top left, are details of the switch.

VALVE READINGS

V	Type	Electrode	Volts	Ma
1	6A7	Anode	200	—
		Osc. anode	100	—
		Screen	80	—
		Cathode	2	—
2	78E	Anode	255	—
		Screen	80	—
		Cathode	2.5	—
3	75	Anode	100	—
		Cathode	1.5	—
4	2151	Anode	250	—
		Screen	200	—
		Cathode	20	—
5	25RE	Cathode	260	—
	302	Barretter	—	—

Pilot lamp 6.3v, .3 amps.

CONDENSERS

C	Mfd	C	Mfd
1	.0025	16	.001
2	.006	17	.8
3	.006	18	.05
4	.05	19	.16
5	.01	20	.00011
6	.01	21	.00011
7	.01	22	.05
8	.00025	23	.00011
9	.00025	24	.00011
10	.01	25	.35
11	.30 mmfd	26	.015
12	.05	27	.16
13	.05	28	.25
14*	.00165	29	.16
15	.50 mmfd	30	.1

* In Run 3 production an additional 250 mmfd condenser C14A is in parallel with C14.

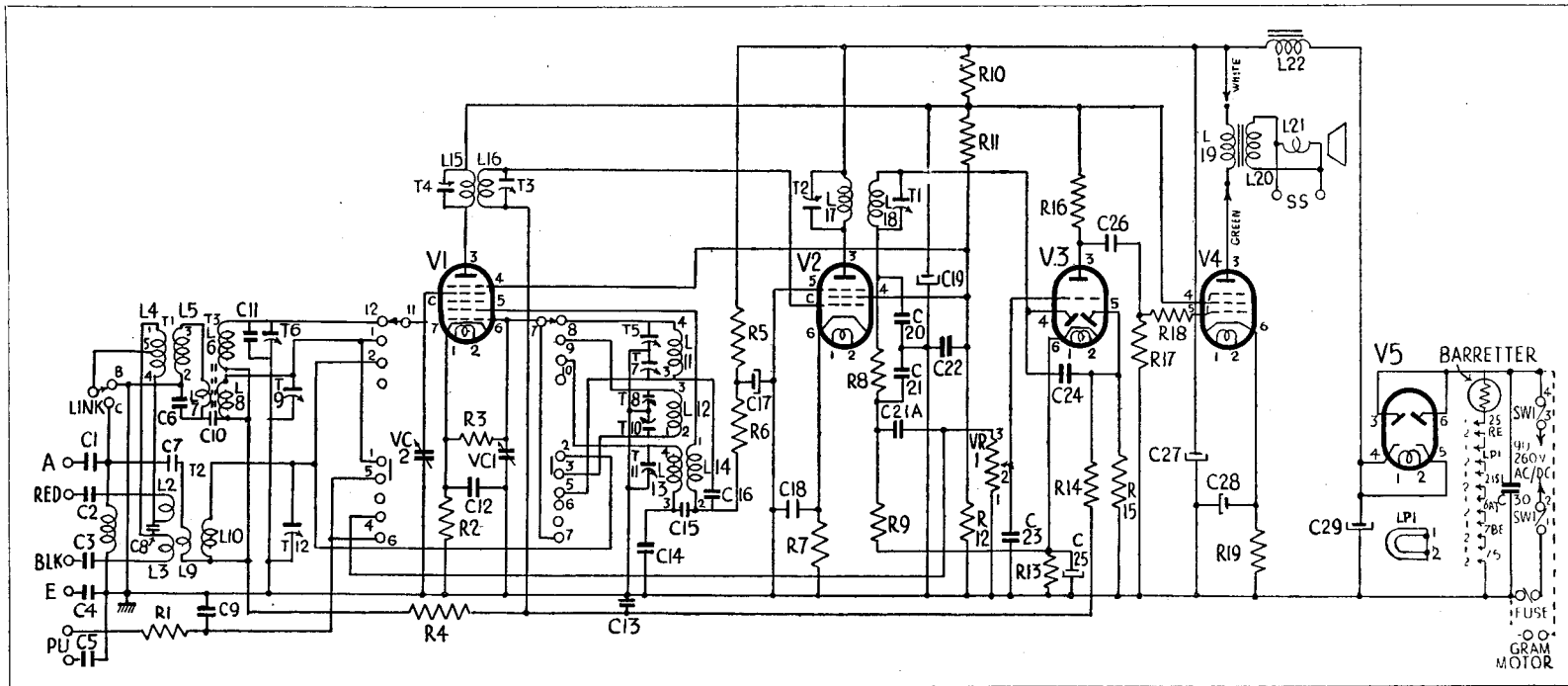

BELMONT 541

Four-valve plus rectifier two-wave-band superhet. Provision is made for the connecting of a pickup and a wire is provided for the attachment of an aerial. No provision for earthing is made. Suitable for mains supplies of 105-125v AC or DC, but additional line cord may be fitted to operate the receiver from mains supplies up to 270v. Made by The Belmont Radio Corporation of America.

THE aerial is coupled via C1 and a coupling coil to the single tuned grid circuit which feeds the grid of the HF pentode valve, V1.

The cathode circuit of this valve comprises R1, R2 and R3, the latter being common to the cathode circuit of the second detector, V3.

The oscillator section comprises the cathode, the suppressor grid, and the anode of the valve, V1. The suppressor is used as the oscillator grid whose circuit is tuned by the VC2 section of the ganged

condenser. Reaction is obtained by medium and long wave coils in the anode circuit.

An intermediate frequency transformer trimmed by T3 and T4 couples the output from V1 to the grid of the IF amplifying valve, V2. This valve is permanently biased by R5 decoupled by C5. AVC is applied to it from the second detector diodes.

A second intermediate frequency transformer couples V2 to the strapped diodes of the double diode triode V3. The diode load is R7 with R8, C7 and C8 as a filter network.

The LF signals are passed by C9 to the volume control, R13, while the DC potential is used for AVC and applied via R6 decoupled by C6 to the grid circuit of V2.

A pickup having a high impedance may be connected to the pickup sockets which are coupled to the volume control via a limiting resistance R14 and tone corrector C11.

The output from V3 is resistance capacity coupled by R9 and C10 to the grid of the output pentode V4. The bias for this valve is derived by connecting the grid via a decoupling network R10, R11, R12, to a tapping on the smoothing choke which is in the HT negative lead.

The anode circuit of V4 has permanent

tone correction effected by C14 and is coupled to the energised loudspeaker via the usual matching transformer.

The heater circuits are arranged in series with R15 voltage dropper which is the line cord. R16 is the shunt resistance for the pilot lamps which is mounted in the chassis.

The rectifying valve, V5, is a double-wave rectifier with separate cathodes: one separate cathode supplies current for energising the field of the loudspeaker while the other cathode circuit supplies the current for the receiver circuit via a tapped smoothing choke and condensers C17 and C18.

GANGING

IF Circuits.—With volume control at maximum and ganged condenser at maximum capacity inject a 456 kcs signal via a .1 mfd condenser, to the control grid cap of V1.

Adjust T1, T2, T3 and T4 for maximum output.

MW Band.—Switch to MW and inject a signal of 1,550 kcs to the control grid of V1.

Adjust gang to minimum capacity and trim T5 for maximum output.

Inject a signal of 1,400 kcs to the aerial wire of the receiver and tune the receiver to the oscillator signal.

Top of chassis view of the Belmont receiver. The design is conventional but compact. The trimmer positions are indicated.

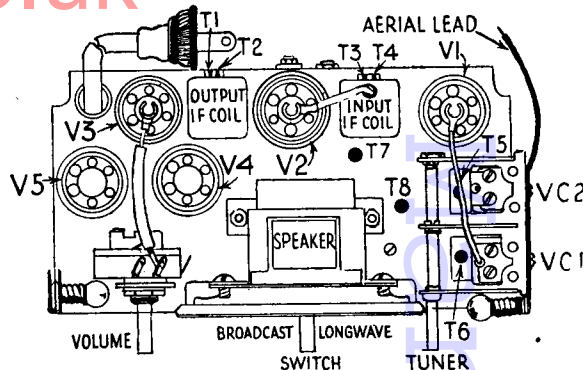

Adjust T6 for maximum output.

LW Band.—Switch receiver to LW and inject a signal of 350 kcs to the aerial wire.

Tune in the signal and then adjust T7 for maximum output whilst rocking gang.

Inject and tune in a signal of 150 kcs and adjust T8 for maximum output whilst rocking gang.

VALVE READINGS

V	Type	Electrode	Volts
1	6D6	Anode	95
		Screen	101
		Cathode	14.5
2	6D6	Anode	98
		Screen	101
		Cathode	2.6
3	75	Anode	*70
		Cathode	1
4	43E	Anode	90
		Screen	101
		Grid	*16.3
5	25Z5	Cathodes	101

Pilot Lamps 6-8v, .15 amps.
* Actual voltages, considerably affected by resistance of voltmeter.

RESISTANCES

R	Ohms	R	Ohms
1	300	9	100,000
2	200,000	10	301,000
3	180	11	28,000
3A	900	12	101,000
4	250,000	13	500,000
5	250	14	500,000
6	250,000	15	126
7	250,000	16	40
8	50,000		

CONDENSERS

C	Mfds	C	Mfds
1	.001	10	.01
2	6 mmfd	11	.003
3	.05	12	.05
4	.05	13	.1
5	.05	14	.006
6	.1	15	.1
7	.0005	16	4
8	.0005	17	12
9	.01	18	8

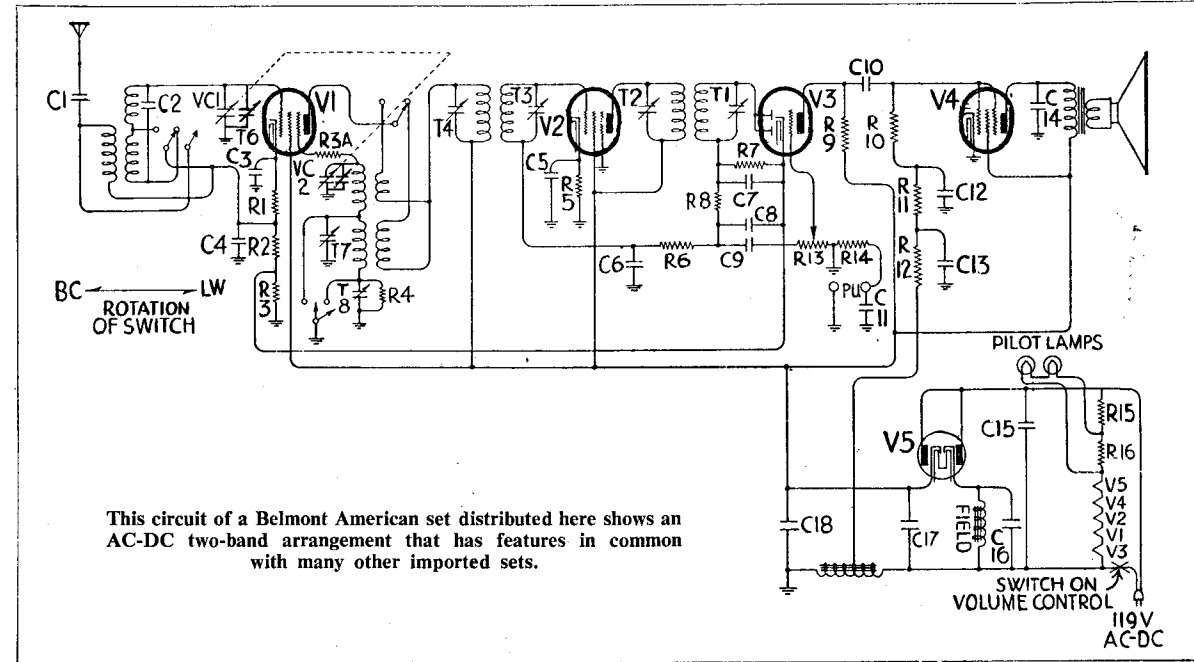

This circuit of a Belmont American set distributed here shows an AC-DC two-band arrangement that has features in common with many other imported sets.

PHILCO MODEL V537

Continued from opposite page

Inject and tune in a 160 kc signal and adjust T7 (nut) for maximum while rocking gang. Readjust T5 at 290 kc.

MW Band.—Switch receiver to MW and tune to 1,400 kc. Inject a 1,400 kc signal and adjust T8 and T9 for maximum output.

Inject and tune in a 600 kc signal and adjust T10 (screw) for maximum while rocking gang. Readjust T8 at 1,400 kc.

SW Band.—Switch receiver to SW, and substitute a 400 ohms resistor for the dummy aerial and inject a 18 mc signal. Set pointer to 18 mc and adjust T11 for the second signal heard from the fully screwed in position of the trimmer. (Care is essential in selecting this signal as the two peaks are narrowly spaced.)

Note.—Due to the very small difference between the pre-selector and oscillator frequencies, the adjustment of T12 will have a tendency to "pull" or change the frequency of the oscillator. By shunting a variable condenser (approximately .0035 mfd) across the oscillator section of the gang and tuning it so that the second harmonic instead of the fundamental beats with the incoming signal, this "pull" can be minimised.

Connect the shunt condenser between T11 tag and chassis and tune it (about half open) for signal at 18 mc. Trim T12 underneath chassis for maximum output. Disconnect shunt condenser and retrim T11.

Check that the 18 mc image is obtained at approximately 17.1 mc.

Feed in and tune a signal of 6 mc and check for correct reading on scale. It should not be necessary to adjust the semi-fixed tracker (C14), but if sensitivity is found to be low at 6 mc very slight adjustment only may be made while rocking the gang. Finally retrim T11 at 18 mc.