

PHILIPS 480A

Three-valve, plus rectifier, three waveband table superhet for A.C. mains. Made by Philips Lamps, Ltd., Century House, Shaftesbury Avenue, London, W.C.2.

Circuit.—Band-pass input is used on medium and long waves and a transformer on short waves. V1 is the frequency-changer, the oscillator section using tuned grid coils with coupled reaction windings. The M.W. coil is iron cored. Trimmer-tuned I.F. trans-

formers link V2, the I.F. amplifier, and V3, the double-diode output pentode.

The A.V.C. diode is fed from V2 anode in the usual way. The volume control, which forms part of the demodulation diode load, is also connected to a negative feed-back tone circuit associated with a special winding on the output transformer.

A full-wave rectifier, V4, is employed, a resistance (R1) being used for smoothing.

DRIVE CORD.—Viewed from front, pass end of cord through hole on drive drum and attach to tension spring.

Pass cord anti-clockwise to bottom of drum and under chassis to drive spindle. Take two turns anti-clockwise round the spindle and bring up and over the top right-hand pulley to the top left-hand pulley.

Pass cord to bottom of drum and round, and then take through hole and attach to the spring.

WARNING.—Some components are screwed to the front panel. These screws must not be too long or too short.

GANGING

I.F. CIRCUITS.—Adjust I.F. trimmers for maximum at 128 kc.

M.W. BAND.—Inject to 1,600 kc. and tune to this point on dial (187.5 metres). Adjust C18, C10 and C6 for maximum. Repeat operations. There are no adjustments for S.W. or L.W.

I.F. FILTER.—Inject strong 128 kc. signal to aerial sockets. Adjust C13 for minimum.

VALVE VOLTAGES

V	Type	Electrode	Volts	Ma.
1	ECH3	Anode	255	1.2
		Screen	70	1.8
		Osc. anode	140	4.3
2	EF9	Cathode	2	7.3
		Anode	250	5
		Screen	90	1.5
3	EBL1	Cathode	2.2	6.5
		Anode	260	32
		Screen	240	3.2
4	AZ1 (Mullard)	Cathode	19	37.2
		Anode	300	51
		Cathode	300	51

Pilot lamps, types 8045D—07.

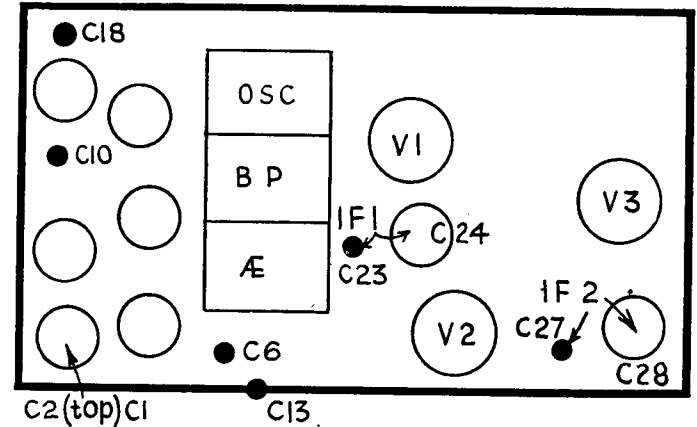

WINDINGS

L	Ohms.	L	Ohms.
2	300	19	9.5
3, 4	less than .5	20	115
6	26	21	115
7	90	22	115
8	4.5	23	90
9	48	24	35
10	4.4	25	700
11	45	26	1
12	2	27	2.5
13, 14	less than .5	29	110
15	1	30	7
16	8	31	7
17	2.5	32	180
18	32	33	180
		34	800

RESISTANCES

R	Ohms.	R	Ohms.
1	1,800	15	1,500
3	.1 meg.	16	50,000
4	47,000	17	12,000
5	330	18	10,000
6	27,000	19	.82 meg.
7	.1 meg.	20	47,000
8	47,000	21	330
9	.65 meg.	22	33,000
9a	.05 meg.	23	.56 meg.
10	1.5 meg.	24	1.8 meg.
11	1 meg.	27	47
12	150	28	82,000
13	390	29	56
14	.56 meg.		

CONDENSERS

C	Mfds.	C	Mfds.
1	.50	21	394 mmfds.
2	15	22	.047
3	490 mmfds.	23	70-100 mmfds.
4	490 mmfds.	24	70-100 mmfds.
5	490 mmfds.	25	.047
6	20 mmfds.	26	.047
7	10 mmfds.	27	70-100 mmfds.
8	.012	28	70-100 mmfds.
9	.039	29	8.2 mmfds.
10	20 mmfds.	30	56 mmfds.
12	30 mmfds.	31	.0033
13	70-100 mmfds.	32	.25
14	.047	33	.001
15	47 mmfds.	34	.0047
16	470 mmfds.	35	.033
18	20 mmfds.	36	.0056
19	33 mmfds.	37	.027
20	1,450 mmfds.	39	.0001
		42	.047
		43	.047

