

AMBASSADOR 551 SERIES

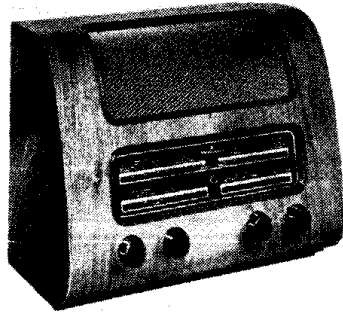

Five-valve three-band superhet with frame aerial and sockets for external aerial, pickup and extension speaker. Walnut finished table cabinet or bookshelf console. Made in AC model for 200-250V 40-60 c.s. and universal model for 200-250V AC/DC by R. N. Fitton Ltd., Brighouse, Yorkshire.

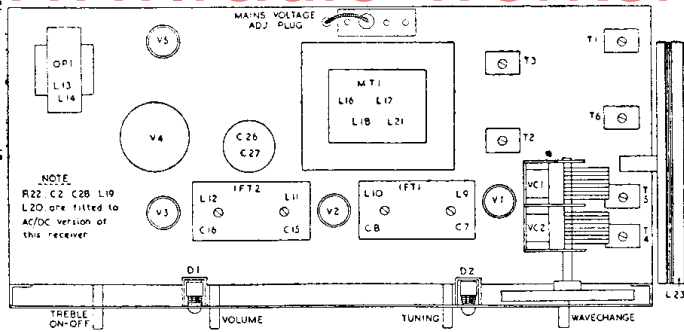

NOTE
R22, C2, C28, L19
L20 are fitted to
AC/DC version of
this receiver

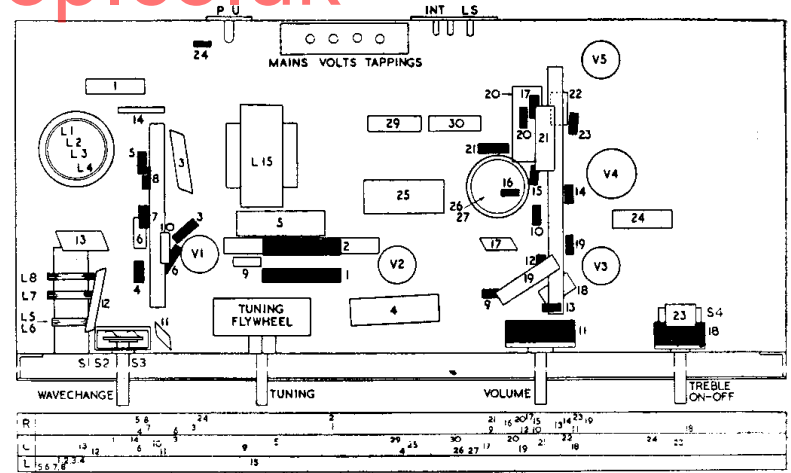
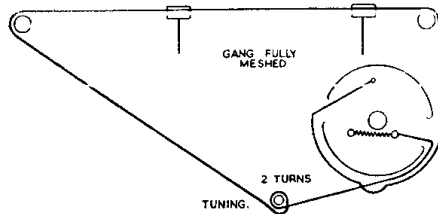

RESISTORS

R	Ohms	Watts
1	22K	1
2	22K	1
3	33	1
4	470K	1
5	47K	1
6	33	1
7	47K	1
8	22	1
9	47K	1
10	2.2M	1
11	500K Potentiometer	1
12	10M	1
13	22	1
14	1M	1
15	100K	1
16	100K	1

R	Ohms	Watts
17	220K	1/2
18	500K Potentiometer (with DPST switch)	1/2
19	100	1/2
20	22	1/2
21	82	1/2
22	56	1/2
23	100K	1/2
24	47K	1/2

INDUCTORS

L	Ohms
1	.25
2	Very low
3	Very low
4	13.5
5	Very low
6	Very low

CAPACITORS

C	Capacity	Type
1	.001 Tubular	1000V
2	.01 Tubular	1000V*
3	2400pF	Silver Mica
4	.1 Tubular	350V
5	.1 Tubular	350V
5	.05 Tubular	350V*
6	120pF	Mica
7	220pF	Silver Mica
8	220pF	Silver Mica
9	120pF	Mica
10	50pF	Silver Mica
11	50pF	Silver Mica
12	6000pF	Silver Mica
13	560pF	Silver Mica
14	300pF	Silver Mica
15	100pF	Silver Mica
16	100pF	Silver Mica
17	15pF	Silver Mica
18	120pF	Silver Mica
19	.02 Tubular	350V
20	.1 Tubular	350V
21	.05 Tubular	350V
22	.02 Tubular	350V
23	200pF	Mica
24	.005 Tubular	1000V
25	50	Electrolytic 12V
26	32	Electrolytic 450V
26	16	Electrolytic 450V
26	32	Electrolytic 350V*
27	32	Electrolytic 350V*
28	.05 Tubular	1000V*
29	.005 Tubular	1000V
30	.005 Tubular	1000V AC, DC model only.

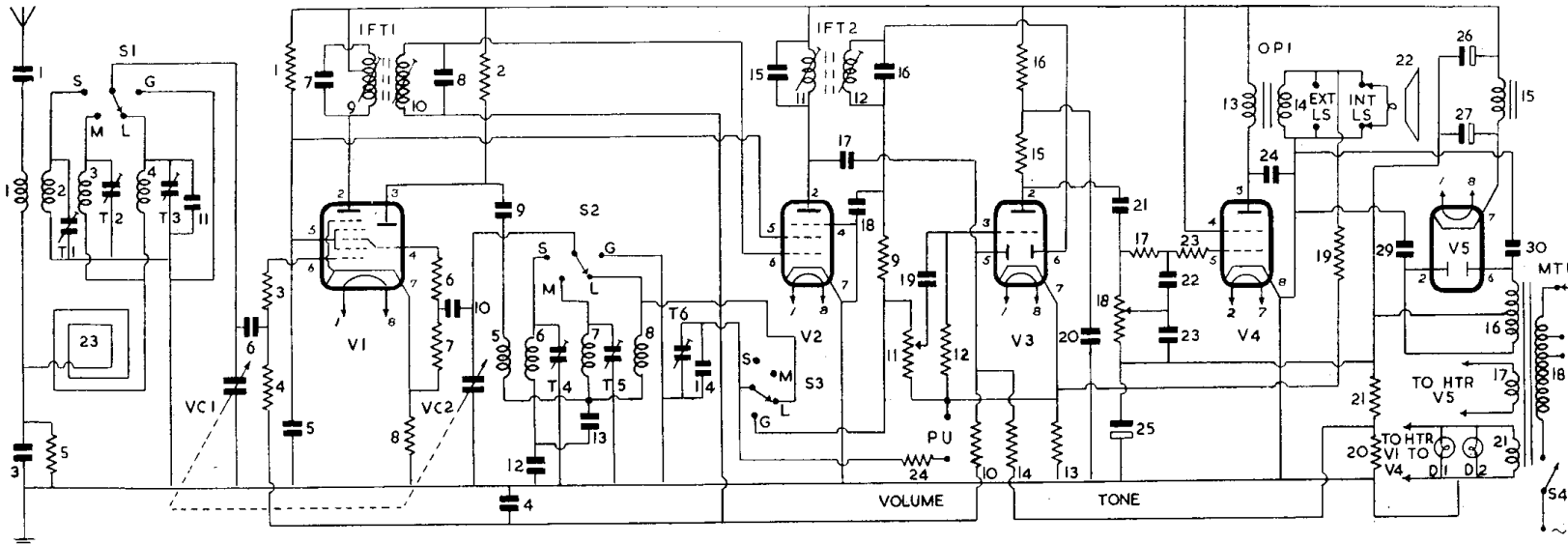

ALIGNMENT INSTRUCTIONS

Apparatus required. Accurately calibrated signal generator covering 10-15, 40-70mc/s with up to 60 per cent. modulation and calibrated low-impedance output attenuator; an oscilloscope or valve voltmeter; and an AC voltmeter for sound output indication.

IF stages. Connect signal generator output through a 1K resistor and .1mF isolating capacitor to g1 of frequency-changer V2. Connect the oscilloscope or valve-voltmeter to cathode of CRT through an HF filter consisting of a 2K resistor shunted by .001mF capacitor. Set signal modulation at 60 per cent.

Adjust coil slugs in the order shown below. As alignment proceeds reduce input signal to give a maximum of 15V RMS on oscilloscope or valve voltmeter.

VISION

Inject 12.5mc/s, adjust L22/23

Inject 11.5mc/s, damp L19 with 2.7K resistor, adjust L20 (top).

Inject 12mc/s, damp L20 with 2.7K resistor, adjust L19 (bot).

OSRAM FLAT FACE ALUMINISED TV TUBE ON TEST

OSRAM recently introduced two new 12in. TV tubes, the 6705A for parallel operation at 6.3V 0.5A and the 6706A for series working at 0.3A 10.5V. They have a moulded, practically flat screen, and a maximum anode rating of 10kV.

Fitted with international octal bases, they are replacing the types 6703A and 6704A and, like those, have aluminised screens and an external conducting coating that can be used for EHT smoothing.

We recently received a 6705A and were immediately impressed by the generous quantity of high-quality glass employed and the high standard of finish. For testing, the tube was fitted to a Viewmaster receiver which had previously used another type of triode tube.

A special rubber mask to fit the nearly flat face of the tube, supplied by Long and Hambly, Ltd., has a wide rubber collar that pulls the window firmly and accurately against the screen.

EHT was increased to approximately 9kV by fitting a boost circuit using a metal rectifier which was recently described elsewhere by Westing-

PHILIPS MONO-KNOB GRAM

A PHILIPS Mono-knob radiogram was brought in for a complete overhaul. After servicing the chassis we attended to the gram motor. Owing to its being unused for a long time the motor was almost completely "gummed-up"; so we dismantled it and cleaned off the hardened grease.

After reassembly we connected the motor to the mains before fitting it back into the gram and, although it operated smoothly and quietly, it functioned at almost twice normal speed.

Despite our efforts with the speed regulating

Inject 12mc/s, damp L17 with 2.7K resistor, adjust L18 (top).

Inject 13mc/s, damp L18 with 2.7K resistor, adjust L17 (bot).

SOUND

Inject 10mc/s, adjust L21, L26 for minimum indication on oscilloscope.

Inject 10mc/s, adjust L27 for maximum deflection on sound output meter connected across primary of OPI.

RF and oscillator stages. The aerial and oscillator tuned circuits consist of tuneable master coils together with factory preset shunt coils which are brought into circuit across the master coils on channels 2 to 5 by means of links. Final channel alignment is carried out by adjustment of master coil cores as below:—

Select appropriate channel coils by means of S1, S2, S3.

Inject appropriate channel sound frequency through 80 ohm resistor to aerial socket and adjust core of L12 for maximum sound output. Inject appropriate vision frequency and adjust core L2 for maximum on oscilloscope.

Inject sound frequency again and adjust L7 for maximum sound output on output meter.

house (details obtainable on request from Advice Bureau).

An excellent picture was obtained, the tube giving a very small spot and remaining in focus over the entire picture area. Brilliance is more than adequate for viewing in room daylight or in normal artificial lighting. The colour is just on the warm, sepia, side of black-and-white. Room reflections at the corners of the screen are notably less than with blown tubes and the viewing angle is increased.

The tube requires slightly more scanning power than those working at about 6kV, but the Viewmaster was able to scan the whole picture area; it would seem that with any receiver designed for a 12in. tube, no difficulty should arise providing the scan circuits are up to standard performance.

These tubes made by the General Electric Co., Ltd., Magnet House, Kingsway, London, WC2, are undoubtedly able to present pictures of the highest standards when supplied in commercial receivers, fitted as service replacements or used in constructed receivers. The retail price of both types is £12 15s., plus £6 12s. 8d.

mechanism we found it impossible to obtain the correct rpm so we switched off and checked the motor coils for partial short circuits.

The windings, however, were perfect. After no little investigation we found that although the gram was a regular 230V AC job, the motor was designed for 110V supply, and in the receiver was fed from a tapping on the primary of the mains transformer.

Whether many prewar Philips grams were fitted with 110V motors, we haven't discovered, but we will certainly bear the possibility in mind.

—G. R. W.

AMBASSADOR 551

from opposite page.

AERIAL. The receiver is fitted with an internal loop for the reception of the more powerful MW and LW stations. Sockets for an external aerial and earth are provided for SW reception and for weaker MW and LW transmissions.

External aerial signal is fed through isolating capacitor C1 to SW aerial coupling coil L1 and thence to frame aerial L23 which is connected to bottom end of MW and LW grid coils L3, L4 respectively. R5, C3 are associated with bottom end aerial feed circuit.

Grid coils L2 (SW), L3 (MW), L4 (LW), which are trimmed by T1, T2, T3-C11 respectively, are switched by S1 to aerial tuning capacitor VC1 and coupled through C6 and grid stopper R3 to g1 of triode-heptode frequency-changer V1.

AVC voltages and a small standing bias, decoupled by R10, C4 are applied through R4, R3 to V1. R8 provides a small degree of negative feedback to cathode. Screen (g2, g4) voltage is obtained from R1 decoupled by C5. Suppressor is internally strapped to one side of cathode. Primary L9, C7 of IFT1 is in the heptode anode circuit.

Oscillator is connected in a tuned-grid shunt-fed circuit. Grid coils L6 (SW), L7 (MW), L8 (LW) trimmed by T4, T5, T6 and padded by C12 (SW) and C12, C13 (MW, LW), are switched by S2 to oscillator tuning capacitor VC2 and coupled by C10 through stopper R6 to oscillator grid.

The gram. switch is utilised to prevent absorption by the LW oscillator circuit on MW, S3 switching out T6, C14. This means that the PU, when left connected and R24 are across these trimmers but effect on LW operation is negligible.

Automatic bias is developed on C10 with R7 as leak. Anode reaction voltages are developed inductively on L5 (SW) and capacitively across padders C12, C13 on MW, LW bands, and are applied through C9 to oscillator anode of which R2 is load.

IF amplifier operates at 420kc/s. Secondary L10, C8 of IFT1 feeds signal together with AVC and standing bias voltages decoupled by R10, C4, to g1 of IF amplifier V2.

Cathode and suppressor are connected down to chassis and screen voltage is obtained from R1 decoupled by C5. Primary L11, C15 of IFT2 is in the anode circuit.

Signal rectifier. Secondary L12, C16 of IFT2 feeds signal to one diode of V3. R11, the volume control, is the diode load and R9, C18 an IF filter.

AVC signal at anode V2 is fed by C17 to second diode of V3. Load resistor R14 is returned to chassis through R20 in negative HT circuit to provide a delay voltage. Delay bias, plus AVC voltage, is fed through decoupling network R10, C4 to grids of V1, V2.

Pickup. Sockets are provided for connection of any high resistance magnetic or crystal pickup. Pickup signal is applied through R24 to S3 which in its gram. position switches signal to volume control R11. Earthy socket is connected to junction of bottom of R11 and cathode feedback resistor R13. When pickup is in use aerial and oscillator coils are switched out and their tuning capacitors VC1, VC2 are shorted down to chassis by S1, S2 respectively.

AF amplifier. Rectified signal on volume

control R11 is fed by C19 to grid of triode section of V3. Bias for grid is developed on C19 with R12 as leak resistor.

Negative feedback from secondary L14 of output matching transformer OPI1 is applied to R13 in cathode of V3. R15 is anode load and R16, C20 provide HT decoupling.

Output Stage. C21 feeds signal at anode V3 through stoppers R17, R23 to beam-tetrode output amplifier V4. Grid resistor is potentiometer R18 which in conjunction with R17, C22, C23 provides variable top cut tone control. Cathode is at chassis potential, hence grid is provided with negative bias by connecting bottom end of grid load R18 to chassis through R20, R21 (decoupled by C25) which are in negative HT return lead.

V4 is transformer coupled by OPI to a 6 $\frac{1}{2}$ in. PM speaker L22. Fixed degree of tone correction is given by C24. Sockets are provided on secondary L14 of OPI for connection of a low-impedance (3 ohm) extension speaker.

HT is provided by an indirectly-heated fullwave rectifier V5 the anode voltages of which are obtained from HT secondary L16 of mains input transformer OPI. Heater current is obtained from L17. Choke-capacity smoothing is given by L15, C26, C27 whilst mains filtering is provided by C29, C30. Reservoir smoothing capacitor C27 is rated to handle 150mA ripple current. Negative side of HT is fed to chassis through R20, R21 decoupled by C25 in order to provide grid bias for V4, delay voltage for AVC diode and standing bias for grids of V1, V2.

Heaters V1 to V4 and dial lights are parallel connected and obtain their current from secondary L21, one side of which is connected to chassis. Primary L18 of MT1 is tapped for input voltages of 200-210, 220-230, 240-250V, 40-100c/s.

Universal model of this receiver differs from the above circuit as follows: Valves used are V1 10C1, V2 10F9, V3 10LD11, V4 10P14, V5 U404.

Heaters are series connected and obtain their current from the mains through a 970 ohm tapped dropper resistor. Rectifier anode is fitted with surge limiter R22.

Output transformer has a separate tertiary winding L19 for connection of extension speaker.

A mains interference filter L20 is also incorporated together with filter capacitor C28. Dial lamps are coupled in series and wired in mains lead to chassis through R21, R20.

Earth socket is isolated from chassis by C2. Reservoir capacitor C27 increased to 32mF.

Mains input is fitted with 1A fuse in each lead and a double-pole ON/OFF switch.

TRIMMING INSTRUCTIONS

Apply signal as stated below	Tune receiver to	Trim in order stated for maximum output
(1) 420kc/s to g1 of V1 via resistive termination	S/C VC2	Coils, L9, 10, 11, 12.
(2) Adjust dial pointers so that they lie vertically down edges of apertures with gang fully meshed.		
(3) 250kc/s to ae socket via dummy aerial	1200 metres	T6, T3
(4) 1.333mc/s as above	225 metres	T5, T2
(5) 15mc/s as above	20 metres	T4, T1