

Bush BA61 Battery Push-button Four

Four valve, three waveband, battery table model superhet with push buttons for three stations and waveband switching, price 9½ gns. complete or £8 19s. 6d. without batteries



CIRCUIT OUTLINE

THE first valve in this receiver is a triode hexode frequency changer, the input of which is provided by coupled aerial circuits for the three bands selected by a special switch. The SW position is arranged so that there is no AVC. The oscillator section is conventional and coupling to V2, the IF valve, is by a permeability tuned transformer.

Intermediate amplification is carried out by a screen pentode with AVC. A further permeability tuned transformer couples this to V3, a double diode triode. Both the diode load and the AVC connection are tapped down on the transformer windings.

The volume control for the triode section of V3 forms the diode load, and is preceded by a resistance capacity filter. For the AVC delay the tapped AVC load is returned to a series bias potentiometer, which is also used to provide bias for the output valve, V4, a pentode.

This is resistance capacity coupled from the anode of the triode section of V3. The output is taken by an ordinary transformer to the speaker, and there is a simple shunt condenser on the anode.

In the push-button position the oscillator has permeability tuned coils and the input circuits are trimmer tuned. The normal input coils are used for this purpose.

CONSTRUCTIONAL FEATURES

THIS receiver is conventional in arrangement and all the components are easy to locate. Condensers C9 and C10, as well as C21, C22 and C23, are located inside the IF cans. These, however, have

removable covers, and it is easy to test or remove these condensers if necessary.

In looking at the circuit it should be observed that the manufacturers do not show the tuned circuits in the normal order. The first tuned circuits are MW, which are then followed by the SW and LW, in that order.

This arrangement necessitates a little careful consideration of trimmer positions and their function. The special trimmer plate diagram, however, should make this quite clear. It will be observed that this plate carries variable inductance adjustments for the push-button positions.

The only other unusual feature is the switch arrangement.

Wave-change Switches.

All the switching is carried out by a multiple switch of the press-button type.

The top row of contacts is available from the underside of the chassis. Those below can only be exposed by removing the assembly as described under the heading of "Chassis Removal."

The switch is of a standard type with L-shaped moving contacts, which in the normal position join two fixed contacts, and when depressed change over to join three contacts.

The action of the switch is obvious by inspection from the underside of the chassis, and the various sets of fixed and moving elements are aligned with the appropriate coils. Accordingly, identification is exceptionally simple.

Chassis Removal.

The chassis is held by four bolts, which are removed from the bottom of the cabinet. After unscrewing the two control

knobs on the front, the chassis can be withdrawn.

The speaker cable is sufficiently long to enable ordinary service work to be carried out without disconnecting it. There are three leads: red, brown and black. The black lead is the chassis earthing wire. The pilot lamps are held on an assembly secured by two special nuts.

The trimmers are reached by removing the escutcheon plate held by means of two fixing screws. To carry out a repair on the coil and switch assembly it should be removed in the following manner:—

Remove the nut from the insulating pillar, the three bolts and distance pieces, and finally the screw holding the supporting bracket. Particularly note that no wires need be removed.

Alignment Notes

I.F. Circuits (465 kcs.)

Connect output meter to set and generator to grid of V2 and inject a modulated signal of 465 kcs.

Damp the anode circuit of the valve with 30,000 ohms in series with .05 mfd. by connecting it between anode and chassis. Adjust L19 for maximum.

Connect the damping circuit between pin 5 of V3 and chassis and adjust L18 for maximum. Use, in both cases, an input below the AVC value.

Connect the generator to the grid of V1 and adjust L9 and L8 for maximum.

(Continued on page 17.)

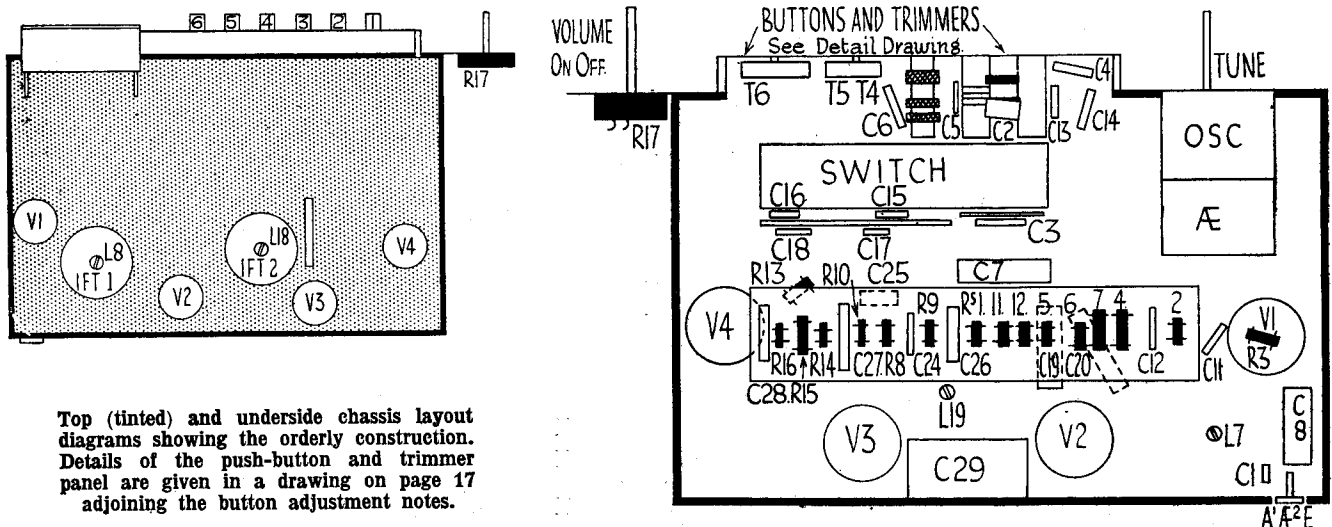

Top (tinted) and underside chassis layout diagrams showing the orderly construction. Details of the push-button and trimmer panel are given in a drawing on page 17 adjoining the button adjustment notes.

10-MINUTE FAULT-FINDER

BUSH BA61

www.radio-workshop.co.uk

Power Test.

Total H.T. feed : 9.5 m.a.; L.T., 0.81 amp.

Output Stage, V4.

Inject 2 volts AF V4 grid. If defective, check :—

Voltagess : Anode, 140; screen, 144.
Resistances : Anode—H.T., 800; grid—chassis, 600,000 ohms.

AF Stage, V3.

Inject .5 volt AF V3 grid. If defective, check :—

Voltage : Anode 65.
Resistances : Anode—H.T., 100,000

ohms; grid—chassis, 5 megohms.

Demodulation.

Inject modulated 465 kcs. signal V2 anode. If defective, check :—
Resistances : L18 4; L19 4; diode—chassis, 550,000 ohms.

IF Stage, V2.

Inject modulated 465 kcs. signal V2 grid. If defective, check :—

Voltagess : Anode, 100; screen, 30.

Mixer Stage, V1.

Inject modulated 465 kcs. signal V1 anode. If defective, check :—

Resistance : V2 grid-chassis, 2 megohms;

L8, 4; L7, 4 ohms.

Inject modulated 465 kcs. signal V1 grid. If defective, check :—

Voltagess : Anode, 144; screen, 35.
Resistance : Screen—HT, 15,000 ohms.

Oscillator Test.

If no signals, tune to local station and inject that frequency plus 465 kcs. at osc. grid. If defective, check :—

Voltage : Osc. anode, 35.
Resistance : Osc. grid-chassis, 40,000

ohms.
If still no signals, test pre-selector and oscillator coils and switching.

Six push-buttons provide for three stations and wave - band switching. The switches are easily identified on the chassis and no special details are necessary (see Switch Notes).

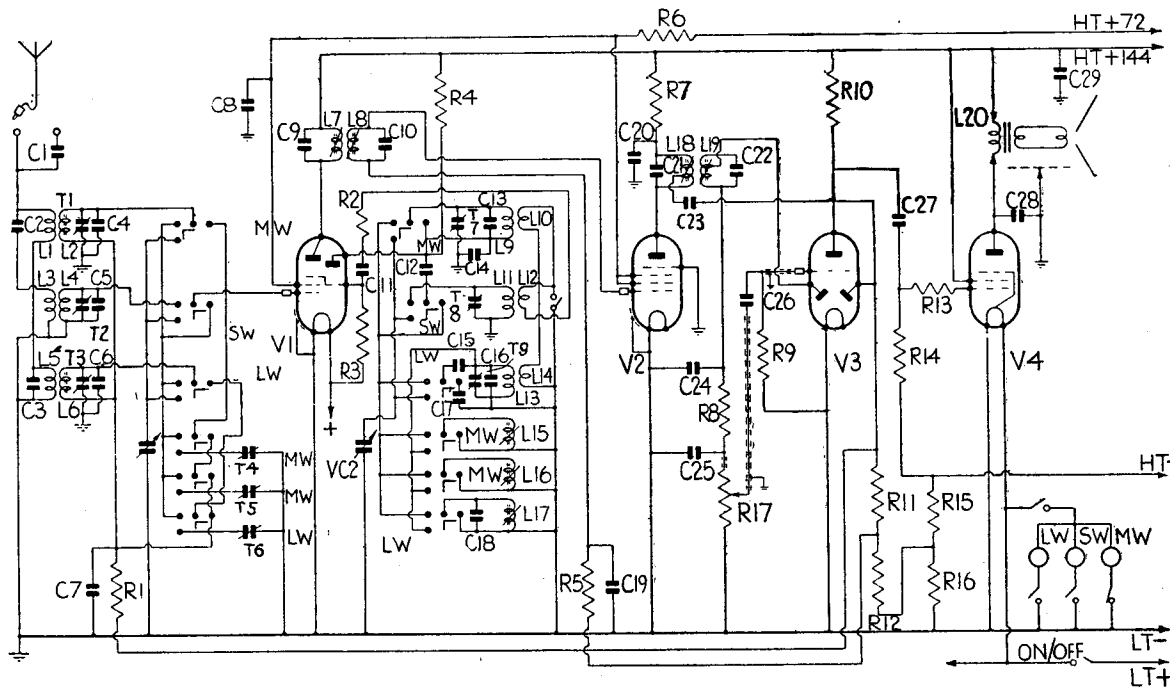

VALVE READINGS

V.	Type.	Electrode.	Volts.	Ma.
1	TP23 (Mazda)	Anode ..	144	.5
		Screen ..	35	.7
		Osc. anode ..	35	2
2	VP2B (Mullard)	Anode ..	100	1.3
		Screen ..	30	.3
3	TDD2A (Mullard)	Anode ..	65	.5
4	PM22A (Mullard)	Anode ..	140	3.5
		Screen ..	144	.7
				9.5
				.81 amp.
			2.5	300

WINDINGS

L.	Ohms.	Range.	Where measured.
1	5	—	Tags 2 and 3.
2	1	—	Tags 1 and 4.
3	Low	—	Tags 2 and 3.
4	Low	—	Tags 2 and 4.
5	30	—	Tags 2 and 3.
6	5	—	Tags 1 and 4.
7	4	—	V1 anode and HT positive.
8	4	—	V2 grid and C19.
9	1.5	—	Tags 1 and 4.
10	1	—	Tags 1 and 3.
11	Low	—	Tags 2 and 4.
12	Low	—	Tags 3 and 4.
13	8	—	Tags 2 and 4.
14	5	—	Tags 1 and 3.

Windings (continued)

15	Low	—	Chassis and switch busbar.
16	Low	—	Chassis and switch busbar.
17	Low	—	Chassis and switch busbar.
18	4	—	V2 anode and R7.
19	4	—	Across leads in coil can.
20	800 or 850	—	On tags red and yellow.

CONDENSERS

	Mfds.
1	Aerial series .. .000005
2	SW aerial series .. .00005
3	LW aerial shunt .. .008
4	MW input shunt .. .000005
5	SW input shunt .. .000005
6	LW input shunt .. .00003
7	V1 AVC decouple .. .05
8	V1 and V2 screen decouple .. .05
9	IFT1 primary shunt .. .00015
10	IFT1 secondary shunt .. .00015
11	Osc. grid .. .0005
12	Osc. anode coupling .. .0001
13	MW osc. shunt .. .000005
14	MW padder .. .000556
15	LW padding .. .000816
16	Osc. shunt .. .000125
17	PB osc. shunt .. .000840

Condensers (continued)

18	LW fixed tune .. .000816
19	V2 AVC decouple .. .1
20	V2 anode decouple .. .1
21	IFT2 primary shunt .. .00015
22	IFT2 secondary shunt .. .00016
23	AVC couple .. .00005
24	HF filter .. .0001
25	HF filter .. .0001
26	LF couple .. .001
27	LF couple .. .03
28	Tone control .. .003
29	HT shunt .. .2

RESISTANCES

	Ohms.
1	V1 AVC decouple .. .1 meg.
2	Het. volt control .. .25
3	Osc. grid lead .. .40,000
4	Osc. anode load .. .40,000
5	V2 AVC decouple .. .1 meg.
6	V2 screen decouple .. .15,000
7	V2 anode decouple .. .7,000
8	HF filter .. .50,000
9	V3 grid resistance .. .5 meg.
10	V3 anode load .. .100,000
11	AVC diode load (part) .. .1 meg.
12	AVC diode load (part) .. .1 meg.
13	V4 grid stopper .. .100,000
14	V4 grid resistance .. .500,000
15	Series bias (part) .. .400
16	Series bias (part) .. .100
17	Volume control .. .500,000

Bush BA61 Battery Four

(Continued from page 12.)

No damping circuit is necessary for these adjustments. Both adjustments are best made with the receiver tuned to about 300 metres.

Short Waves (16.5 to 51 metres).

Connect generator to aerial and earth through dummy aerial and tune set and generator to 18 metres.

Adjust T8 and T2 for maximum.

Check the calibration at 50 metres.

Medium Waves (198 to 560 metres).

Tune set and generator to 300 metres and adjust T7 and T1 for maximum.

There is no padding operation, but check the calibration at 500 metres.

Long Waves (850 to 2,000 metres).

Tune set and generator to 1,500 metres and adjust T9 and T3 for maximum.

There is no padding operation, but check the calibration at 1,900 metres.

Press Buttons

Provision is made for one long-wave station and two medium waves as follows :-

Button 1, 1,200-2,000 metres; Button 2, 340-450 metres; Button 3, 200-350 metres.

The oscillator controls, L15, L16 and L17, have approximately calibrated scales showing the position of the adjusting screw for any particular wavelength.

The oscillator adjustments, selection buttons and pre-selector trimmers are

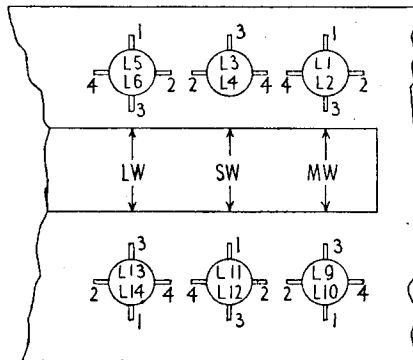
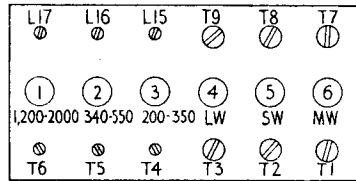

Details of the push-button trimmer panel and the coil assembly are given in these diagrams. The coil connections are numbered for reference in conjunction with the Windings table on page 13.

arranged in vertical lines as shown on the diagram.

The desired button is set up by depressing it, adjusting the corresponding oscillator inductance and then the pre-selector coil trimmer. It is important to note that adjustment of the LW oscillator trimmer, T9, will affect the push-button settings, and if this trimmer is moved the push-button adjustments must be readjusted.

Similarly, adjustment of T1 may affect T4 and T5, while adjustment of T3 may affect T6.

Pick-ups on AC-DC

INSTALLING pick-ups for use on AC-DC receivers sometimes involves certain difficulties, as the possibility of shocks exists where a direct connection is made to one side of the mains supply.

A moulded bakelite pick-up and tone-arm is preferable to a metal one in such cases. A fixed condenser should be inserted in series with each pick-up lead, if they are not already fitted on the chassis.

Where a screened cable is used to reduce hum, it will generally be found that the hum is actually increased when the screening is connected direct to earth. The only satisfactory way in most cases is to connect the screening to the chassis.

If the cable has to be installed in such a position where the user can come into contact with the screening, a cable which has a layer of insulation over the outer metal screening should be used.—M.B.

Pilot Model T63—Alignment

(Continued from page 10.)

IF Circuits (Frequency 451 kcs.)

Connect generator to V1 grid and tune gang to maximum on MW and connect output meter to the receiver.

Long Waves (900 to 2,100 metres.)

Connect generator through dummy aerial to the aerial and earth of the set and tune set and generator to 1,100 metres and adjust T5 and T6 for maximum.

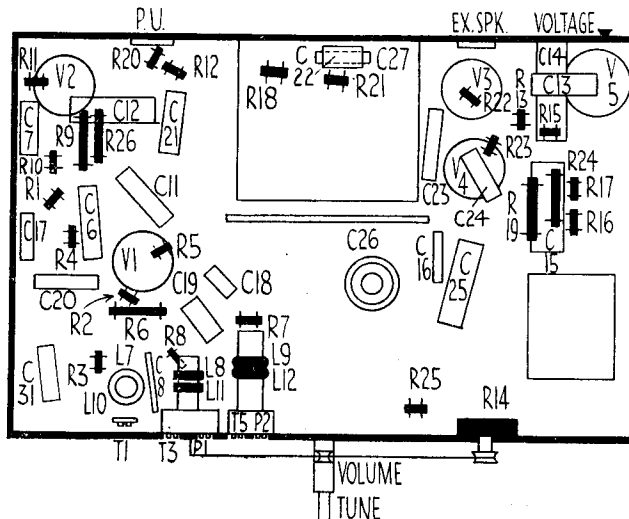

Underside layout diagram of the Pilot T63 showing the orderly construction. Trimmers are situated both above and below the chassis. The top "deck" view is on page 10.

Inject a low value modulated 451 kcs. signal and adjust T1, T2, T3, and T4 for maximum in that order.

Make sure the value of the injected signal is below the point at which the AVC begins to operate.

Tune set and generator to 1,900 metres and adjust P2 simultaneously rocking the gang.

Repeat the two operations until no improvement results

Medium Waves (200 to 550 metres.)

Tune set and generator to 200 metres and adjust T7 and T8 for maximum.

Tune set and generator to 500 metres and adjust P1 for maximum simultaneously rocking the gang.

Repeat the operations until no improvement results.

Short Waves (16 to 55 metres.)

Tune set and generator to 18 megacycles and adjust T9 and T10 for maximum. Check the calibration through the scale and make a slight compromise if necessary. There is no padding operation.

Note that the 18 mcs. point is marked on the scale which is calibrated elsewhere in metres.

Interference Cure

A COMPLAINT of bad interference was investigated and it was found that by switching the main switch on and off and also certain other light switches the noise ceased and was caused to come on again.

The house wiring was disconnected from the mains and with a low range Ohmmeter in circuit lamps and switches were tapped for loose connections. A fault was found at a lead near the meter which altered the resistance of the circuit when pulled. Opening the rubber showed a fractured wire which had apparently caused sparking as the building vibrated.

BUSH BA61

Four-valve, three waveband, battery superhet with three press-button station selectors and press-button wavechange for manual tuning. Made by Bush Radio, Ltd., Power Road, Chiswick, London, W4.

THE aerial is coupled to tuned-grid coil assemblies L1, L2 (MW), L3, L4 (SW), L5, L6 (LW) tuned by VC1 section of the ganged condenser. Press-button station selection by S4-S6 connecting trimmers in parallel with L2 (MW) and L6 (LW).

The hexode control grid of V1, the frequency changer, is fed from the pre-selector circuit AVC controlled on the medium and long wavebands, but not on SW. The oscillator circuits comprise the coupled coils L9, L10 (MW), L11, L12 (SW), and L13, L14 (LW), C12 being the parallel feed to the tuned oscillator circuits.

Fixed padding is obtained on MW by C14, on LW by C15.

On press-button tuning padder C15 (LW) is connected in series with C16 to form a parallel capacity to L13 (LW) master oscillator coil. On SW, coils L10 (MW) and L14 (LW) are connected in parallel by S13. The LW coil L13 is the master oscillator circuit for the press-button stations, tuned by switching in parallel three separate auxiliary variable iron cored coils L15-L17.

A permeability-tuned IF transformer L7, L8 couples the frequency-changer to V2, the IF amplifier. A second IF transformer L18, L19, forms the coupling to the signal diode of V3, the double-diode triode.

The rectified LF output is developed across VR1 and passed via C26 to the control grid of the triode section. The AVC diode is fed via C23 from L18 and provides a DC potential to the control grids of V1 and V2. Additional bias for the AVC line is obtained from the negative drop across R16.

V4, the pentode output valve is resistance-capacity coupled to V3 by R10, C27, R13, R14.

A fixed degree of tone correction is effected by C28. Grid bias is automatically obtained from the voltage drop along R15, R16 in the HT negative line.

GANGING

IF Circuit.—A damping circuit consisting of a 30,000 ohms resistance in series with a .05 mfd fixed condenser must be used where indicated to obtain correct alignment of the IF circuits.

Switch receiver to MW (about 300 metres), volume control at maximum. Connect the output from the service oscillator between the control grid of V2 (top cap VP2B) and chassis and feed in a 465 kc signal. Connect damping circuit from the anode V2 to chassis.

Adjust L19 for maximum reading on the output meter.

Connect damping circuit between the tapping on the secondary winding (green wire to pin 5 on V3) and chassis.

Adjust L18 for maximum output. It is not necessary to use the damping circuit when trimming the first IF transformer.

Feed the 465 kc signal to the control grid of V1 (top cap TP23) and adjust L9 and L8 for maximum output.

Calibration Check.—Before trimming, check the setting of the tuning pointer in relation to the gang condenser. With the vanes fully meshed, the centre of the pointer should coincide with the top of the wavelength on the scale.

SW Band.—Switch receiver to SW, turn volume control to maximum and set pointer to 18 metres.

Inject a 18 m signal into aerial socket (max. sensitivity). Adjust T1 and T2 for maximum output. Check calibration on 50 metres.

MW Band.—Press medium-wave button. Inject and tune in a 300 m signal. Adjust T3 and T4 for maximum output. Check calibration on 500 metres.

LW Band.—Press long-wave button. Inject and tune in a 1,500 m signal and adjust T5 and T6 for maximum output. Check calibration on 1,900 metres.

Press-Button Circuits.—Connect the aerial and earth to their sockets. It may be found helpful to ascertain the nature of the desired programme, by first tuning in the required station on the manual tuner.

Continued on page vi

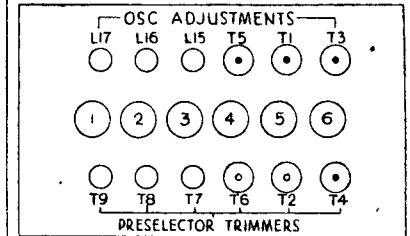
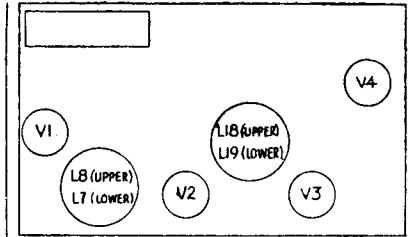

These diagrams identify the main components on the chassis and show where the trimmers are located.

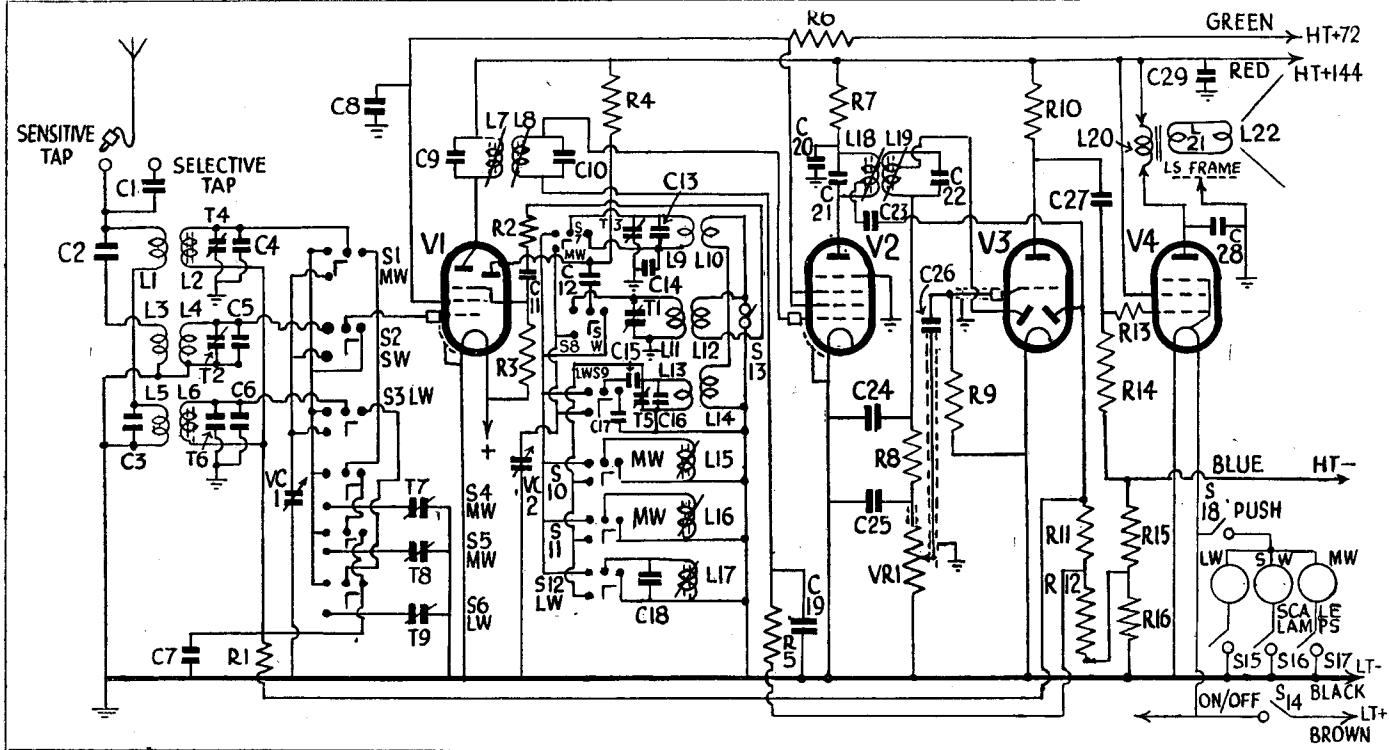

The circuit of the BA61, a battery set with PB tuning.

CONDENSERS

C	Mfd
1	.0001
2	.00005
3	.0008
4	5 mmfd
5	5 mmfd
6	.00003
7	.5
8	.5
9	.00015
10	.00015
11	.0005
12	.0001
13	5 mmfd
14	556 mmfd
15	316 mmfd
16	125 mmfd
17	340 mmfd
18	316 mmfd
19	.1
20	.1
21	.00015
22	.00016
23	.00005
24	.0001
25	.0001
26	.001
27	.03
28	.003
29	2

VALVE READINGS

V	Type	Electrode	Volts	Ma
1	TP23 Mazda	Anode	144	.5
		Osc. anode	35	2
		Screen	35	.7
2	VP2B Mullard	Anode	100	1.3
		Screen	30	.3
3	TDD2A Mullard	Anode	65	.5
		Screen	144	.7
4	PM22A Mullard	Anode	140	3.5
		Screen	144	.7

Scale lamps, 2.5v, .3A. Measurements taken with new HT battery reading 144v; aerial disconnected, vol. control at maximum on MW 1,000 o-p-v meter.

RESISTANCES

R	Ohms	R	Ohms
1	1 meg	10	100,000
2	25	11	1 meg
3	40,000	12	1 meg
4	40,000	13	100,000
5	1 meg	14	500,000
6	15,000	15	400
7	5,000	16	100
8	50,000	VRI	500,000
9	5 meg		

WINDINGS

L	Ohms	L	Ohms
1	.5	12	.1
2	1	13	.3
3	.05	14	.5
4	.05	15	.04
5	.30	16	.05
6	.5	17	.05
7	.4	18	.4
8	.4	19	.4
9	1.5	20	.850
10	1	21	.3
11	.05	22	2.4

EMERSON 414 *continued from page v*

455 kc. AVC voltage is applied to the HF, pentagrid and IF valves.

The double-diode-triode is resistance-capacity coupled by R7, C17, R8, to the beam power output valve. C18 is for tone correction and in models 439 and 441 there is an additional tone control with C23, and its accompanying switch.

All the cathodes are returned to chassis. The heater circuit has all the valves in series, the dial light being taken from a tapping on the rectifier heater. The set will work with the dial light out, but it is advisable to replace as soon as possible if it should burn out. If one of the valves is removed or burns out the dial light will not glow.

If replacements are made or the wiring disturbed in the HF section, the receiver should be carefully realigned.

In operating the receiver on DC, it may be necessary to reverse the line plug for correct polarity.

The colour coding of the IF transformer leads is as follows:—

- Grid—green. Anode—blue.
- Grid return—black. HT+—red.

GANGING

IF Circuits.—Rotate the variable condenser to the minimum capacity position. Feed 455 kc to the grid of the 12SA7

valve (pin No. 8) through a .01 mfd. condenser and adjust the four IF trimmers for maximum response.

Wave Trap.—Feed 455 kc to the external aerial lead and adjust the wave trap condenser until minimum response is obtained.

HF Circuits.—Set the dial pointer at 140. Feed 1,400 kc from the ganging oscillator into a loop of wire about 12 in. in diameter. Hold this radiating loop about 12 in. away from and parallel with the aerial coil.

Advance the input to the loop until a satisfactory deflection is obtained on the output meter. Adjust first the oscillator trimmer for maximum response and then the aerial trimmer.

The oscillator condenser is the front section of the variable condenser.

VALVES AND VOLTAGES

Models 414, 415, 419	Models 439, 441
1 7B7 .. HF amplifier	6SS7
2 12SA7 .. Pentagrid modulator-oscillator	12SA7
3 7B7 .. IF amplifier	6SS7
4 12SQ7 .. Detector, AF amplifier and AVC	12SQ7
5 50L6 .. Beam power output	50L6
6 35Z5 .. Half-wave rectifier	35Z5

NB.—A few receivers of model 439 will be found to use 0.3 amp heater valves instead of the 0.15 amp heater types shown above. The valve combination is then as follows: 6SG7, 6SA7, 6SK7, 6SQ7, 25L6, 25Z6. The circuit arrangement is substantially the same.

Continued in next column

From the Engineer's Case Book

ENGINEERS are sometimes puzzled to find that a set is unstable at certain parts of the dial after a condenser in the HF or LF section has been replaced.

This may be due to one of two causes. Either the original condenser was of the non-inductive type and the replacement is one of the type in which the layers are wound in a roll; or the outer layer of the condenser may accidentally have been connected to a point at high HF or LF potential and may be causing reaction.

In the former case there is no alternative but to fit a non-inductive type; but in the second, all that is necessary is to turn the condenser round so that the outer layer of foil is at the low HF potential end of the circuit (usually HT+, or chassis).

As condensers are not always marked, the experiment has to be tried to find out which side is actually the outer.

Rectifier Burn-outs

AFTER a rectifying valve has been burnt out, the trial of a new one may well result in that also being destroyed.

Continued from previous column

Readings taken with a 1,000 ohms-per-volt meter. Voltages shown are from point indicated to chassis side of on-off switch with volume control at full volume and no signal. The mains voltage (after the line cord) for these readings is 117 volts AC. Measurements on DC will be lower than those shown.

Valve.	MODELS 414, 415 and 419.			
	Anode.	Screen.	Cathode.	Heater.*
7B7 ..	18	88	0	5.5
12SA7 ..	88	88	0	12.0
7B7 ..	88	85	0	5.5
12SQ7 ..	30	—	0	12.0
50L6 ..	82	88	5.6	50.0
35Z5 ..	—	—	120	35.0
	MODELS 439 AND 441.			
6SS7 ..	50	57	0	6.0
12SA7 ..	87	89	0	12.0
6SS7 ..	88	89	0	6.0
12SQ7 ..	30	—	0	12.0
50L6 ..	82	89	5.3	50.0
35Z5 ..	—	—	115	35.0

Voltages across pilot light, 4.5 volts.
Voltage across speaker field, 32 volts.
Resistance of speaker field, 450 ohms.
*Measured across heater pins.

section returned to the proper position. After reganging, the set then functioned in a perfectly normal manner.—A.W.L.

Sets Should be Sealed

COULD makers devise some simple arrangement whereby a receiver could be "sealed" by an engineer after repairing? This would deter unauthorised persons from meddling with the apparatus and protect both the owner and the repairer.

Too often after a set has been repaired a dabbler comes along and tries to improve on the work done. If damage is done, the original repairer is notified and left in ignorance of the meddling and may be out of pocket as a result.

Use for Old Valves

ALWAYS keep old AC-DC valves (including USA valves of all types). They are very useful, if their heaters are OK, for testing in a universal set where a new valve is wanted.—F.D.C.

BUSH BA 6I *Continued from page vii*

Press the button allocated to the particular station, turn the oscillator screw (clockwise for increase in wavelength) above the button, so that the index mark coincides with the wavelength required. Then carefully rotate the screw for the loudest output.

Adjust the pre-selector trimmer below the button (clockwise for increase in wavelength) for loudest output. Finally, make a careful readjustment of each tuned circuit. The remainder of the tuned circuits associated with each button should be adjusted in the same manner outlined above.

Adjustment of the LW oscillator trimmer T5 (painted red) will affect tuning of the three press-button stations. Therefore, when this trimmer is used to adjust the manual LW circuit always retrim the automatic stations oscillator adjustments L15 to L17.

Adjustment of the MW manual aerial trimmer T4 may necessitate retrimming the MW press-button trimmers T7 and T8.

Adjustment to the LW manual aerial T6 may necessitate retrimming the LW press button trimmer T9.

The replacing of the frequency-changer V1, may slightly alter the oscillator tuning. To compensate for this, press the button covering the 200-350 metre band (No. 3 button) and adjust the LW oscillator trimmer T5 until the station is correctly tuned; the remaining stations will then be automatically returned.

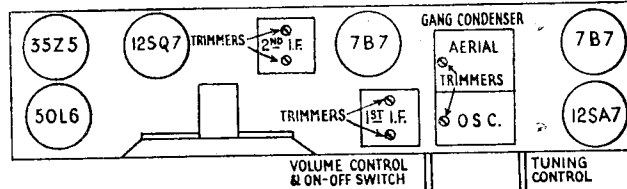

Left: The top of chassis layout for the models 414, 415 and 419.

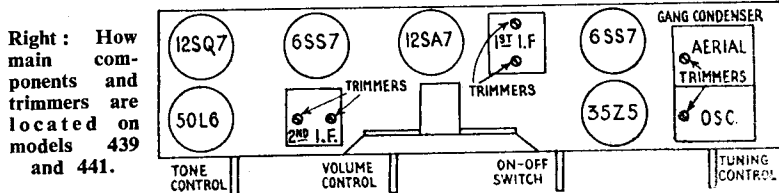

Right: How main components and trimmers are located on models 439 and 441.

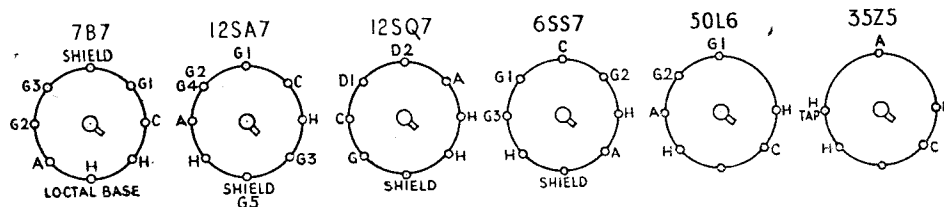

Left: Pin connections of the valves used in the Emerson 414 series.