

BUSH**Model BAC.31**

www.radio-workshop.co.uk

General Description : Four-valve, two-waveband, "all dry" battery portable receiver. The receiver is designed for use on A.C. mains, with the addition of a power unit Type 42 providing optional A.C. mains/battery operation.

Power Supply : H.T. 90 volts (Ever Ready Batrymax B107); L.T. 7.5 volts (Ever Ready AD.31). Consumption, H.T. 10 mA. at 90 volts, L.T. 50 mA. at 7.5 volts.

Wavebands : M.W. 187-560 m.; L.W. 1071-1898 m.

Intermediate Frequency : 470 kc/s.

Valve Analysis : Measurements taken on Avometer Model 7, 1000-volt range under no-signal conditions.

| <i>Valve</i> | <i>Anode, Volts</i> | <i>Anode Current, mA.</i> | <i>Screen, Volts</i> | <i>Screen Current, mA.</i> |
|--------------------|---------------------|---------------------------|----------------------|----------------------------|
| V1 DK92 | 90 | 1.3 | 62 | 0.2 |
| (osc.) | 42 | 1.9 | — | — |
| V2 DF91 | 90 | 1.2 | 62 | 0.4 |
| V3 DAF91 | 42 * | 0.12 * | 22 * | 0.02 * |
| V4 DL94 | 85 | 4.2 | 90 | 0.8 |

* Subject to wide variation. Voltage drop across R12, 1.3 volts.

Alignment Procedure : For R.F. alignment a test loop comprising three turns of insulated wire of approximately the same dimensions as the frame aerial. The test loop should be placed about 2-3 ft. from, and parallel to, the frame aerial. The output of the signal generator should be connected directly to the loop. Before alignment check the position of the pointer in relation to the tuning gang. With plates fully meshed, the pointer should coincide with the right-hand edge of the scale calibration.

I.F. : With receiver tuned to 300 m., inject a 470-kc/s. signal to pin 6 of V2 and chassis and adjust secondary and then primary of 2nd I.F.T. Transfer signal input to pin 6 of V1 using the same order of adjustment and decrease output of test signal as circuit approaches resonance. Peak each circuit once only.

R.F. : It is essential to align M.W. before L.W.

| <i>Operation</i> | <i>Set Signal Generator to</i> | <i>Set Receiver to</i> | <i>Adjust for Maximum Output</i> |
|------------------|--|------------------------|----------------------------------|
| (1) M.W. | 600 kc/s. | 500 m. | L4-5 |
| (2) | 1500 kc/s. | 200 m. | TC4, then TC2 * |
| (3) | Repeat (1) and (2) and check calibration | | |
| (4) L.W. | 214 kc/s. | 1400 m. | TC3, then TC1 |
| (5) | Check calibration | | |

* In some models TC2 is not connected.

www.radio-workshop.co.uk

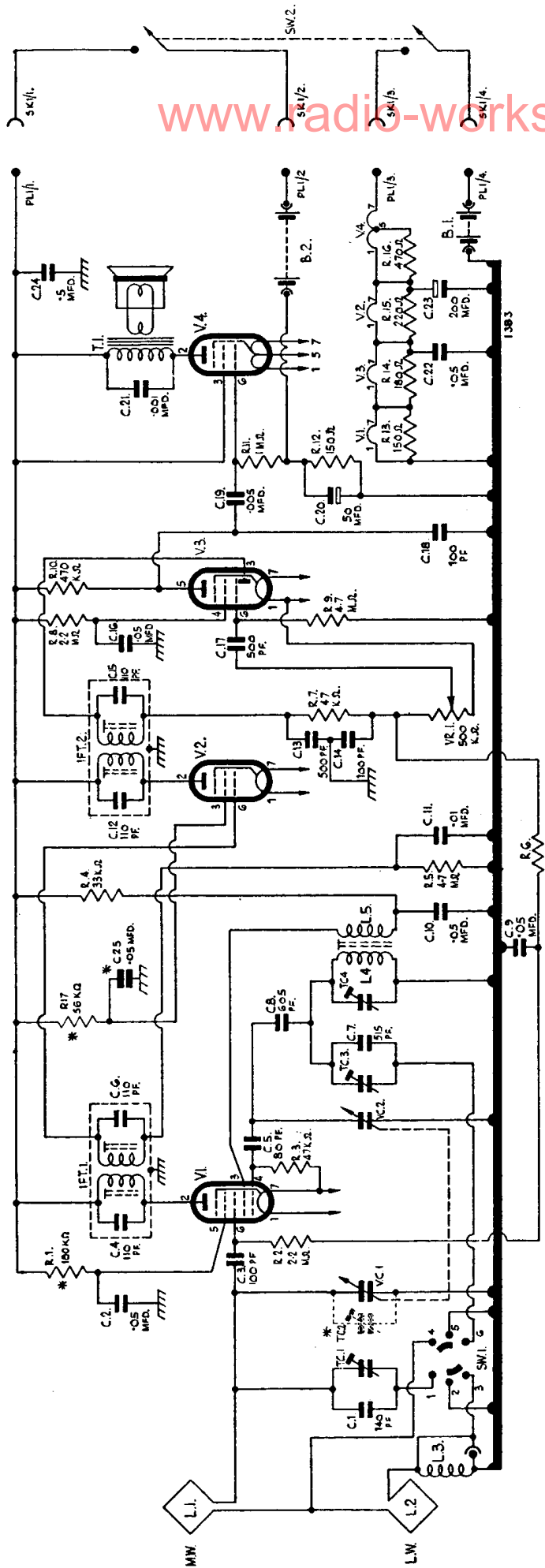

| | | |
|------------|--|------------|
| RESISTORS | R.1. R.2. R.3. R.4. R.5. R.6. R.7. R.8. R.9. R.10. R.11. R.12. R.13. R.14. R.15. R.16. | RESISTORS |
| CONDENSERS | C.1. C.2. C.3. C.4. C.5. C.6. C.7. C.8. C.9. C.10. C.11. C.12. C.13. C.14. C.15. C.16. C.17. C.18. C.19. C.20. C.21. C.22. C.23. C.24. C.25. | CONDENSERS |

- D.C. Resistances (ohms)
- L1 2
 - L2 8.5
 - L3 4.5
 - L4 2
 - L5 2.5
 - IFT windings 12.5
 - T1 (pri.) 500

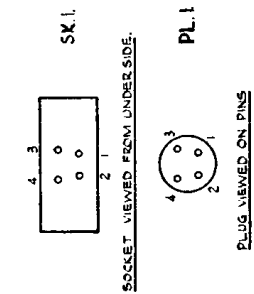
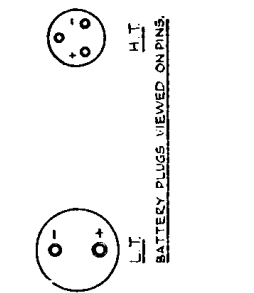

CIRCUIT DIAGRAM—BUSH MODEL BAC.31

B.T.G. VALVE BASE VIEWED FROM UNDERSIDE.

Trimmer Layout : The four trimmer adjustment positions (above chassis) are mounted in the following order from front to back : TC₂, TC₁, TC₃, TC₄. The L₄₋₅ core adjustment is immediately in front of the 1st I.F.T.

Modifications : On earlier models the screens of V₁ and V₂ are fed through a common 33k resistor, R₁₇ and C₂₅ not being fitted. On the later models TC₂ is not used.

POWER UNIT TYPE 42

General Description : This power unit is suitable for use with the BAC.31 as an alternative to dry batteries. It delivers approximately 80 volts and 6.5 volts for H.T. and L.T. respectively.

Power Supply : A.C. mains, 200-250 volts (three adjustment tappings), 40-100 c/s. Consumption approximately 16 watts.

Valve : EZ41.

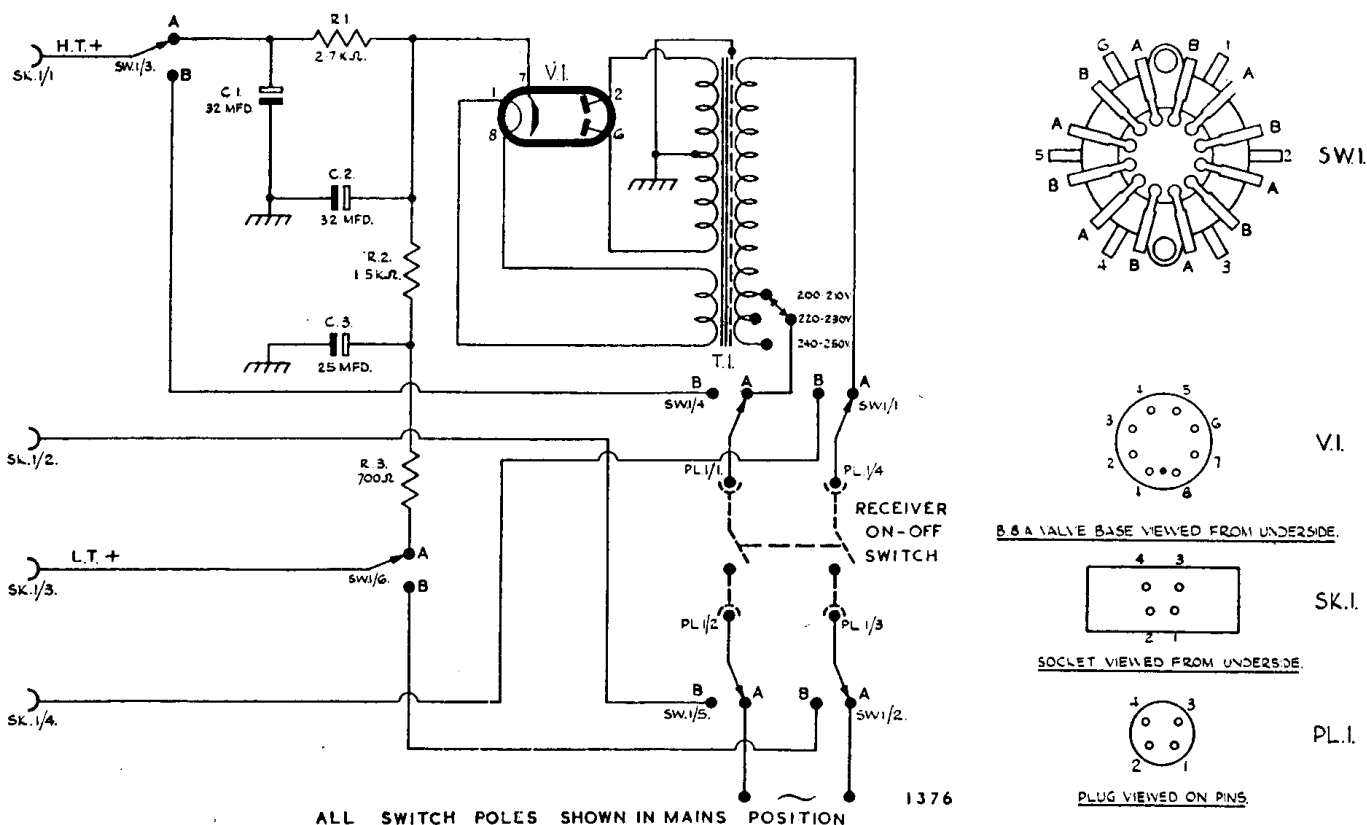

CIRCUIT DIAGRAM—BUSH POWER UNIT TYPE 42