

BUSH DAC 63 and RG 63 DC-AC, AC 63 DC-AC Auto and DUG 62

Four-valve, plus rectifier, three-waveband superhet with five station press buttons and press button wavechange. Table model, DAC 63; console, DUG 62; radiogram, RG 63 DC/AC; autoradiogram, RG 63 DC-AC Auto. For operation from DC or AC mains; 180-260v, 40-80 cycles (table and console) or 200-250v, 25-60 cycles (radiograms). Made by Bush Radio Ltd., Power Road, Chiswick, London, W.4.

AERIAL input via isolating condenser C1 and L1 to tuned grid circuit L2, C4 (MW) via C2 and L3 to L4 C5 (SW), C3 and L5 to L6 C6 (LW). Waveband switching by S1 (MW), S2 (SW), S3 (LW). Pre-set station selection operated by S4-S8 connect trimmers in parallel with L2 (MW) and L6 (LW).

The hexode control grid of the frequency changer V1 is fed from the preselector

circuits and is AVC controlled. Triode oscillator grid coils L7 (MW), L9 (SW), and L11 (LW) tuned by VC2. Reaction to the SW circuits is via C15 to L10.

Waveband switching for the oscillator circuit by S9 (MW), S10 (SW), and S11 (LW). Pre-set station selection connected in parallel with the master oscillator coil L11 by switches S12-S16, tuning by variable iron cores in coils L13-L17. When the LW switch S11 is in the out position contacts 1 and 2 are shorted, thus the LW paddler C17 is connected in series with C19 across L11, forming the additional trimmer for the pre-set stations.

IF transformer C9, L18, L19, C10 couples the hexode anode of V1 to the control grid of the pentode IF amplifier V2. A second IF transformer C26, L20, L21, C27 passes on the signal to the signal diode of the double diode triode V3.

The signal diode is fed from a tapping on L21 via C31; the load resistance being R11. The LF signal is passed via C32, the volume control VR1 and grid stopper R13 to the triode grid of V3. IF filter is by R9 and C29.

Gramophone pick-up input on the table model is applied through isolating condensers C33 and C34 to VR1 and chassis, but see notes at end of this review for differences in gram. models.

The AVC diode of V3 is fed from a tapping on L20 via C28. R17 is the load resistance, and AVC applied via R1, C7, R7, C25 as bias for V1 and V2. Delay voltage is obtained from the drop across cathode biaser R16.

The tuning indicator control grid is fed from V3 signal diode load R11 through the network R12, R10 and C30.

Resistance capacity coupling by R15, C37 and R18 is employed between the anode of V3 and the control grid of the pentode output valve V4. Variable tone control by C39 and VR2 in the anode circuit.

The full-wave rectifier V5 supplies HT current via smoothing choke L25, C40 and C41.

Valve heaters, scale and escutcheon lamps are in series with the barretter across the mains filter circuit L26, L27, C42. When the manual tuning buttons are in the "out" position, the scale lamps are shorted out by special switches S17 (MW), S18 (SW) and S19 (LW) ganged to these buttons. Mains on/off switch is at back of receiver.

GANGING

IF Circuits.—Tune receiver to 300m (MW manual tuning button No. 8). Set volume control to maximum and tone control to low.

Below, layout identifying major parts on the top of the chassis, and right, a diagram of the push-button assembly showing the trimmers.

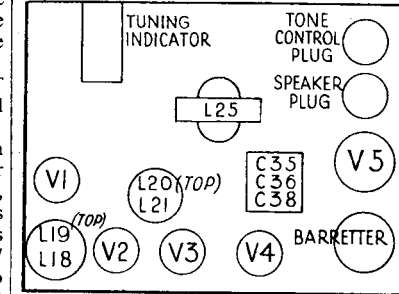
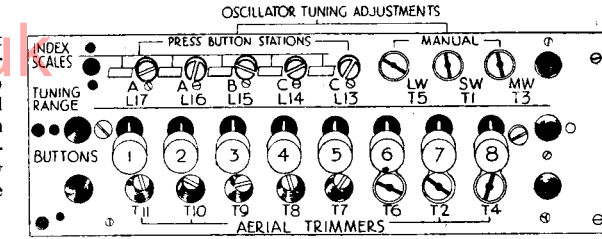

Inject a 465 kc signal into the control grid of V2. Adjust the core of L21 (underside of chassis; adjust through hole in metal cover on resistance panel) for maximum output.

Continued on page vii

On 230v, AC, vol control max, no signal.

VALVE READINGS

V	Type	Electrode	Volts	Mas
1	302THA Cossor	Anode Screen Osc anode Cathode	260 60 60 1	1 1.6 4.8 —
2	VP13C Mullard	Anode Screen Cathode	195 140 Nil	6.5 2.6 Nil
3	TDD13C Mullard	Anode Cathode	120 2.3	2.3 —
4	PEN36C Mullard	Anode Screen Cathode	220 260 12	33 5.2 —
5	Mullard UR3C	Cathode	260	58
Tuning indicator	Triode anode		30	Very small
Mullard TV6	Target anode Cathode		260 2.8	1 —

Pilot Lamps, 6.2v, .3 amps.
Barretter: Phillips' Type C1.

CONDENSERS

C	Mfds	C	Mfds
1	.005	22	.05
2	.50 mmfd	23	.05
3	.0008	24	.05
4	5 mmfd	25	.05
5	5 mmfd	26	.00015
6	30 mmfd	27	.00016
7	.5	28	50 mmfd
8	.005	29	.0001
9	.00015	30	.05
10	.00015	31	.0001
11	.05	32	.005
12	30 mmfd	33	.03
13	10 mmfd	34	.1
14	556 mmfd	35	2
15	50 mmfd	36	.50
16	15 mmfd	37	.03
17	316 mmfd	38	.50
18	130 mmfd	39	.03
19	340 mmfd	40	.24
20	316 mmfd	41	.16
21	316 mmfd	42	.01

RESISTANCES

R	Ohms	R	Ohms
1	1 meg	13	100,000
2	250	14	10,000
3	30,000	15	50,000
4	30,000	16	1,000
5*	50,000	17	1 meg
6	10,000	18	500,000
7	1 meg	19	300
8	2 meg	20	100,000
9	250,000	21	75
10	2 meg	22	75
11	500,000	VR1	500,000
12	2 meg	VR2	50,000

*100,000 ohms on RG models.

The set is a DC-AC model with careful HF filtering in the mains leads.

WINDINGS

L	Ohms
1	.5
2	.05
3	.05
4	.05
5	.14
6	1.5
7	1
8	.05
9	.1
10	2.7
11	2.3
12	2
13	2.3
14	2
15	2.3
16	4
17	4
18	4
19	4
20	4
21	4
22	650
23	.5
24	2.5
25	200
26	6
27	6

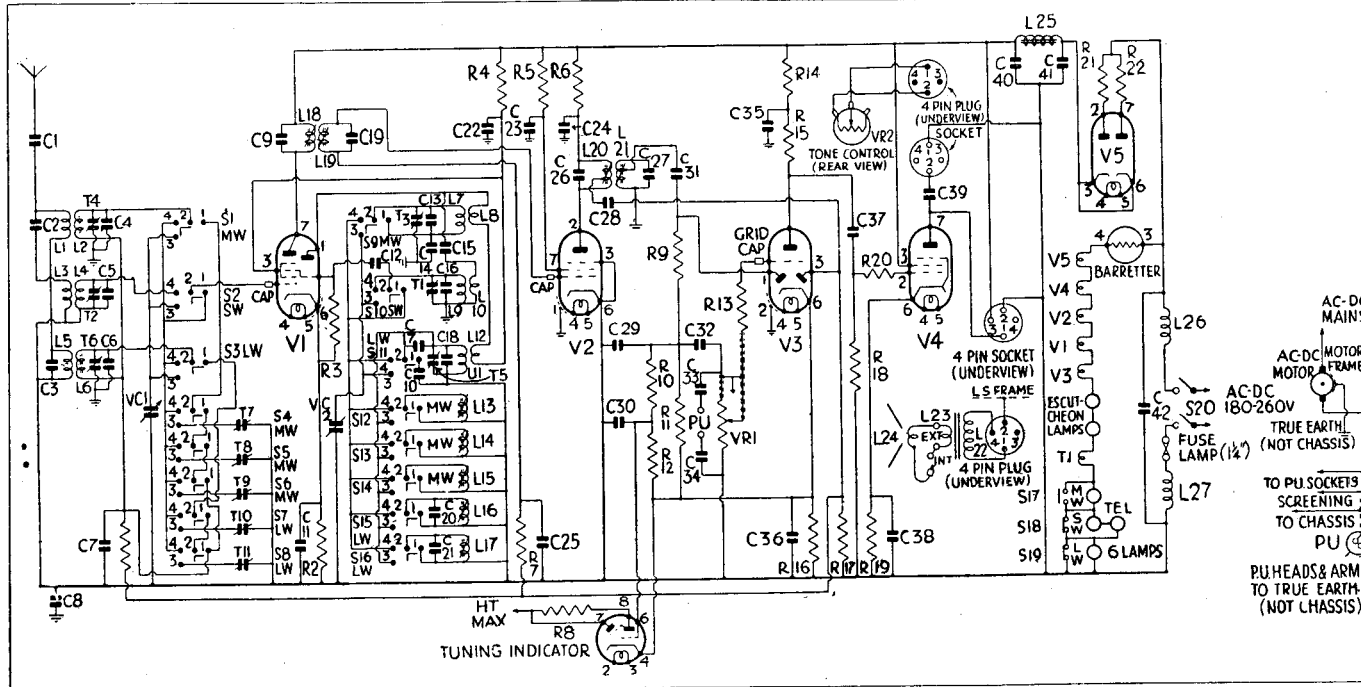

MARCONI 260, 285

Continued from opposite page

Adjust T1 and T2 for maximum output. The trimmer, T3, on VC3 section of the ganged condenser need not be adjusted and should be left unscrewed.

LW Circuits.—Switch receiver to LW. Inject and tune in a 1,200-m signal. Adjust T4 and T5 for maximum output.

Ferrocort Circuit.—As will be seen from the circuit diagram, the circuit differs very little from that of the original issue. Instead of HF transformer coupling a tuned anode circuit is employed with reaction applied via reaction coils and variable resistance to earth.

The screening grid of V1 is also controlled by VR2 as before, but there is no potential divider network, R1-R2, HT being fed directly from the HT line via R2.

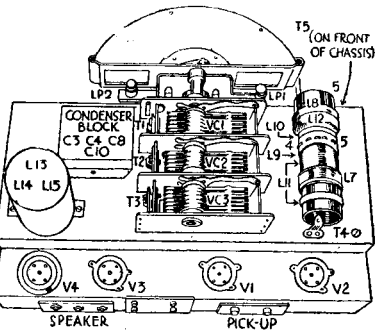

The top of chassis layout diagram for issue 1 of these Marconiphone and Columbia sets. It will be seen that a horizontal coil assembly is employed and the aerial section of the gang condenser is at the dial end.

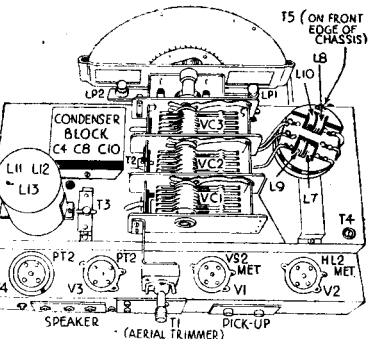

In issue 2 of this chassis a different coil unit is employed and the condenser block is also different. The aerial gang section is at the rear of the chassis.

EKCO AW 108

Continued from page iv

GANGING

Note.—A special wax is used for sealing the cores, and this should be melted by a hot soldering iron with $\frac{1}{4}$ -in. diameter bit. A screwdriver should not be used for dislodging the wax, as the coil formers may break from their mountings. These remarks do not apply to later models, in which cores are fixed by a plastic substance.

IF Circuits.—The manufacturers do not recommend the adjustment of T1 in any circumstances.

Leave chassis in cabinet and adjust volume control to maximum. Keep input signal low and use a 0.5v output meter across EXT LS sockets.

Set gang condenser to minimum and wavechange switch to MW. Turn Fidelity Control switch to "Normal" (anticlockwise).

Inject a 460 kc signal via a .02 mfd condenser to grid cap of V1. Adjust primary and secondary cores of 1st, then 2nd, IF transformers for maximum meter reading. (First IF primary core should first be screwed right out, then slowly in to the first peak.)

Repeat adjustment of all four and re-seal cores.

Calibration Check.—If station tuning positions do not correspond with scale markings, check that pointer covers the line representing 1,950m when gang condenser is turned to its electrical maximum. The pointer is held to gang by spring-loaded screws and, if incorrectly set, may be pushed through a small angle. The mounting plate is accessible from back of receiver.

MW Band.—Leave chassis in cabinet. Set wavechange switch to MW and turn tuning indicator to 200m.

Inject a 1,500 kc (200m) signal into A and E sockets via a dummy aerial with dipole switch closed.

Fully unscrew T2, then screw it in slowly for maximum meter reading.

Inject and tune in a 550m signal, and adjust T3 and T4 for maximum output while rocking gang.

Then adjust T5 for maximum output while rocking gang.

Check adjustments of T3 and T4 at 200m for maximum output.

LW Band.—Switch receiver to LW. Tune receiver to 1,000m and inject a 300 kc signal.

Adjust T6 for maximum output.

Tune receiver to 1,700m and inject a 176.3 kc signal. Adjust T7 and T8 for maximum output.

BUSH DAC 63

Continued from page v

Inject signal into control grid of V1, and adjust core of L19 (top of coil can) for maximum output. Adjust the core of L18 (underside of chassis) for maximum output.

Recheck the four adjustments with the signal generator still connected to the control grid of the V1.

Manual Tuning Circuits (Buttons 6, 7, and 8).—Before trimming check the position of the tuning pointer. With the vanes fully meshed the centre of the pointer should coincide with the top of the wavelength lines on the scale. Remove the escutcheon plate from the front of the cabinet by means of the two fixing screws if the chassis has not been removed.

It is important to see that the celluloid protection plate over the adjustments is fixed into position after servicing.

SW Band.—With volume at max., press the SW button No. 7, set pointer to 18 metres.

Inject a 18m signal via dummy aerial

and adjust T1 and T2 for maximum output. Check calibration on 50m (6.00 mc).

MW Band.—Press MW button (No. 8), set pointer to 300m. Inject a 300m signal, and adjust T3 and T4 for maximum output.

Check calibration on 500m.

LW Band.—Press LW button No. 6; set pointer to 1,500m. Inject a 1,500m signal, and adjust T5 and T6 for maximum output. Check calibration on 1,900m.

Adjustment of the LW oscillator trimmer T5 (painted red) will affect the tuning of the pre-selected stations (buttons 1 to 5) after manual circuit adjustments; therefore the oscillator adjustments L13 to L17 must be readjusted.

Adjustment of the MW aerial tuning trimmer T4 will necessitate readjustment of the MW pre-set station trimmers T7 to T9. Also, any adjustment of the LW aerial tuning trimmer T6 will affect the tuning of the LW pre-set station trimmers T10 and T11.

Pre-set Station Buttons 1 to 5.—Connect the aerial and earth to their sockets. It may be found helpful to ascertain the nature of the desired programme by first tuning the station on the manual tuner.

Adjust T9 for maximum output while rocking gang.

Check adjustments of trimmers T7 and T8 at 1,000m for maximum output.

Turn wavechange switch to SW, scale pointer to 15 mc, and inject a 15 mc signal. Adjust T10 for maximum output; peak at the setting requiring less trimmer capacity.

Check T10 adjustment to ensure that oscillator is not tuned to image signal. With high service oscillator input the image should be heard at approximately 14.1 mc on receiver scale. If the signal is not at this point but at 15.9 mc, trimmer T10 should be readjusted until signal can be tuned in at 15 mc and image at 14.1 mc.

Reduce oscillator input to previous low level, and adjust T11 for maximum output while rocking gang.

Leave service oscillator set to 15 mc and tune in image signal at 14.1 mc. If the latter is as strong as the 15 mc signal, readjust T11.

Tune receiver and service oscillator to 6 mc. Adjust T12 for maximum output while rocking gang.

Check adjustment of T11 at 15 mc.

IF Filter.—Adjust service oscillator for maximum output at 460 kc. Screw in dipole switch and tune receiver to 560 metres. Adjust L12 core for minimum meter reading. Reseal core.

Press the button allocated to the particular station. Turn the core adjustment (clockwise for increase in wavelength) above the button so that index mark coincides approximately with the wavelength required. Then carefully rotate the core for maximum output.

Adjust the aerial tuning trimmer below the button (clockwise for increase in wavelength) for maximum output.

Finally make a careful readjustment of each tuned circuit. The remainder of the tuned circuits associated with each button should be adjusted in the same manner as outlined above.

Console Modifications.

Same chassis as in table model, minus "Telefic" and tuning indicator and associated components. A larger speaker is fitted.

RG and Auto RG

C33, C34, deleted. PU (700 ohms) connected via radiogram switch to top of VR1 and chassis via 5-pin plug and socket. Mains on/off switch incorporated with VR2. Mains input via pins three and four of 4-pin plug associated with VR2.

INDEX

January-December, 1943

Make	Model	Page	Month
Alba	35	v	Feb.
"	40 Univ.	iv	Jan.
"	52 AC	vi	Aug.
American Data	.15-amp. Valve Range	iv	"
"	1.4 v. Min. Range	vi	"
Belmont	541	vi	Dec.
"	800	vi	Jan.
"	845	vi	vi
Burndept Bush	252	vii	Feb.
"	DAC63, RG models & DUG62	v	Dec.
Beethoven	"Little Prodigy" 909 AC	iv	July
Columbia	640	iv	May
"	640A	vi	"
"	1001, 1003	vi	Dec.
Ekco	SH25	vii	Aug.
"	AD37	vii	Oct.
"	AD65	vii	March
"	AD76	iv	Oct.
"	AC97	v	"
"	AW98	iv	Feb.
"	AW108	iv	Dec.
"	PB189	iv	Oct.
GEC	BC3440/1/2/4/8	vii	Nov.
"	3646	vii	May
HMV	12	v	Aug.
"	15	v	"
"	532	iv	May
"	532A	iv	"
"	532C	v	"
"	551	iv	Aug.
"	551A	iv	"
"	1100	iv	Sept.
"	1106	iv	Nov.
"	1107	vi	"
"	1504	iv	"
"	1750	v	"
Invicta	B29B, Trans. 650, Port.	v	June
Kolster Brandes	381	vi	July
"	875	v	June
Marconiphone	260	vi	Dec.
"	285	"	"
"	950	v	Nov.
Murphy	B24	iv	July
"	B25	iv	"
"	A38	v	Sept.
Personal Receiver Philco	581	vii	April
"	A638	vi	March
Philips	V7A	iv	Feb.
"	229B	vii	July
"	805 A	vi	Sept.
"	805X	vi	"
Pilot	"Twin Miracle"	vii	"
Pye	Mite	ii	Jan.
RCA Midget	45X11, 45X12, 45X15	vii	April
RGD	516	iv	June
Telsen	464	vii	"
Ultra	25	iv	March
"	55	viii	Jan.
"	88	iv	March
Feature Articles.			
Causes of Noise			Jan.
Types of Whistle and Hum			Feb.
Locating Noise			March
Intermittent Faults			April
Single-Tuned Aerial Input Circuits			May
Bandpass Circuits			June
RF Amplifier Stage Circuits			July
Principles of Frequency Changing Stage			Aug.
Modern Frequency Changer Circuits			Sept.
Variable Selectivity and other IF Circuits			Oct.
Diodes and Triodes for Demodulation			Nov.
AVC Circuits			Dec.