

BUSH PB50

Four-valve, plus rectifier, AC mains superhet without manual tuning, but with push buttons for six MW stations and two LW stations. Suitable for 200-250 volts, 40-100 cycles. Made by Bush Radio, Ltd., Power Road, Chiswick, London, W4.

THE frame aerials L1 (LW), L2 (MW) are connected by press-button switches S1—S8 to the trimmers TC1—TC8, which tune the frame aerials to any desired station within the wavelength range of the buttons. The tuning circuit is completed

by C1 and external aerial and earth leads may be attached to the sockets provided for increasing range.

Signals are fed via C9 to the grid of the frequency changer V1, which is permanently biased by R4, decoupled by C11. Automatic volume control is obtained from the bias line via decoupling components R2, C6.

The oscillator section of V1 employs tuned grid circuits with anode feed-back by L4. L3 is the master oscillator coil trimmed by T5 and press-button tuning is effected by connecting variable iron cored coils L5—L12 across L3.

The intermediate-frequency signal is transferred by the IF transformer L13, L14 to the grid of the amplifying pentode V2, which has AVC applied to it via R10, decoupled by C21.

A second IF transformer L15, L16 transfers the

signal from V2 to the signal diode of the double diode triode V3. In the anode circuit of V2 tags are provided across the anode resistance R9 so that a high resistance voltmeter may be used as a tuning indicator when trimming the circuits.

The load resistance for the signal diode of V3 is R12, with filtering effected by R11 and C20. The low-frequency signals are fed via C23 to the volume control VR1, and thence through R13 grid stopper to the grid of the triode section of V3.

The AVC diode is fed from the anode of V2 via C19, the load resistance being R17 and delay volts are obtained from the cathode biasing resistance R16 decoupled by C25.

Resistance capacity coupling by R15, C26 and R18 couple the LF signals from V3 to the grid of the output pentode V4, which is cathode biased by R20, decoupled by C27. A permanent degree of tone correction is effected by C29 and variable tone control is provided by C28 and VR2 across the

There is no manual tuning in the PB50, and it is solely a push-button set giving eight pre-selected stations.

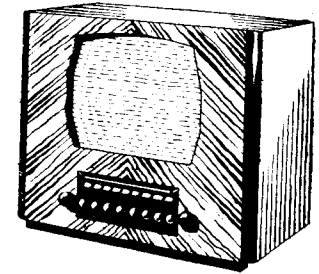

primary of the output transformer L17, L18. L20 is the speech coil and L19 the hum-bucking coil.

High tension is derived from the full-wave

Continued overleaf

RESISTORS

R	Ohms	R	Ohms
1	2,000	12	500,000
2	500,000	13	100,000
3	30,000	14	10,000
4	100	15	50,000
5	1 meg	16	1,000
6	50	17	1 meg
7	20,000	18	500,000
8	50,000	19	100,000
9	10,000	20	200
10	2 meg	VR1	500,000
11	250,000	VR2	50,000

WINDINGS

L	Ohms	L	Ohms
1	10	14	4
2	1	15	4
3*	2.9	16	4
4	1.2	17	500
5	2	18	.07
6	2	19	.3
7	1.4	20	2
8	1.2	21	2,000
9	1	22 (total)	550
10	1	23	.15
11	.7	24	.1
12	.7	25 (total)	26.5
13	4		

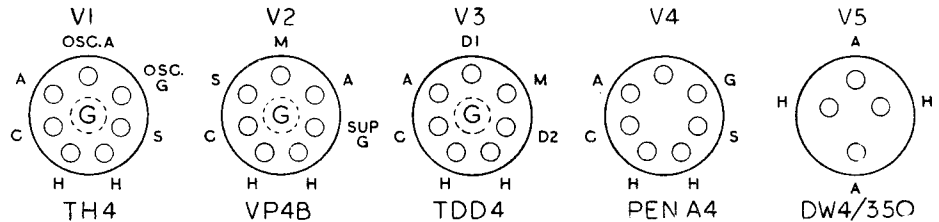

Above: valve bases as seen with valve or set chassis inverted. Letters indicate the internal electrodes to which pins are connected.

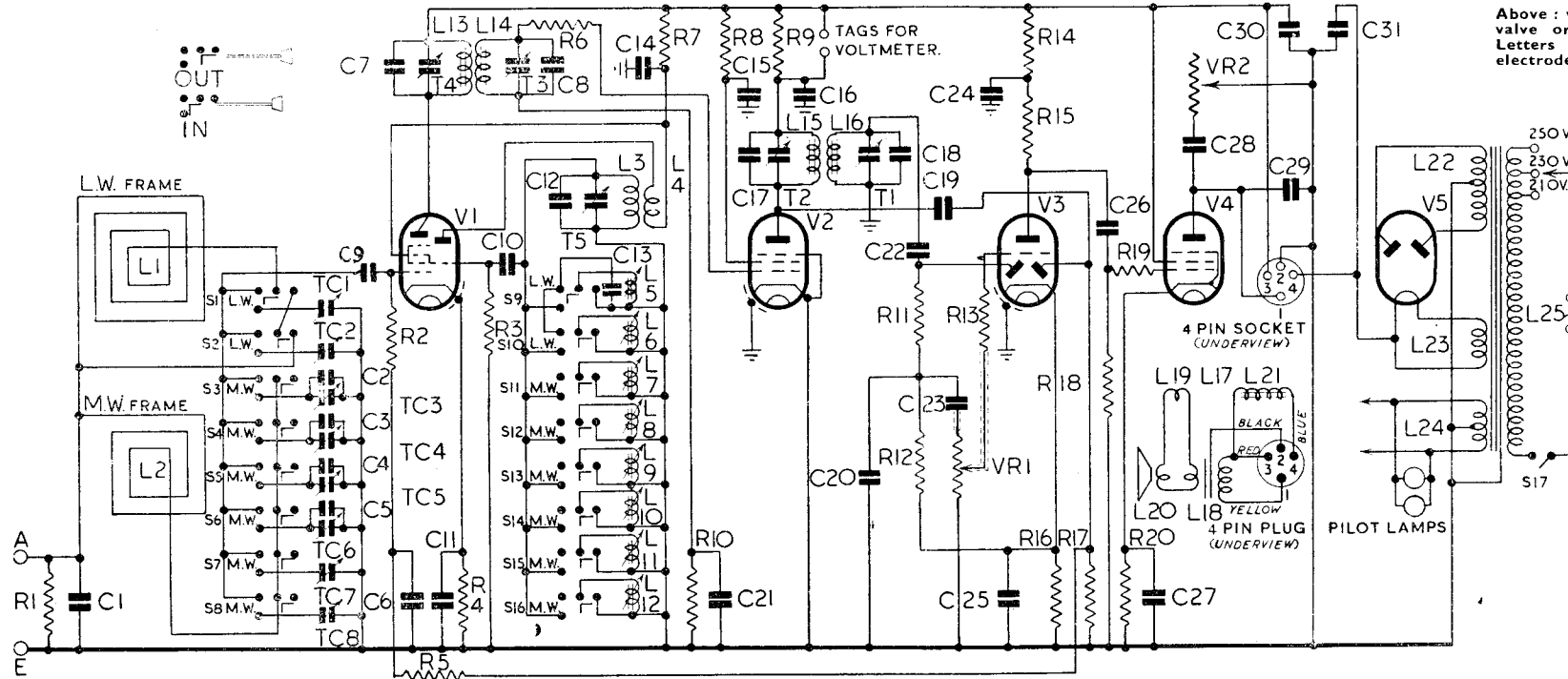

CONDENSERS

C	Mf/ds
1	.2
2	250 mmfd
3	160 mmfd
4	60 mmfd
5	60 mmfd
6	.05
7	180 mmfd
8	180 mmfd
9	.0001
10	60 mmfd
11	.05
12	316 mmfd
13	316 mmfd
14	.05
15	.05
16	.05
17	180 mmfd
18	180 mmfd
19	.0001
20	.0001
21	.05
22	.0001
23	.005
24	2
25	50
26	.03
27	50
28	.03
29	.003
30	16
31	8

The circuit follows the conventional pattern for a four-valve plus rectifier AC superhet except for the provision of eight push-button circuits in place of the usual switched coils and variable condensers. Frame aerials are fitted but an external collector can be connected.

BUSH PB50—Continued

rectifier V5, with smoothing effected by the field coil L21 and condensers C30 and C31.

GANGING

IF CIRCUITS.—Switch the receiver to MW and adjust it to 300 m approximately by pressing an appropriate button. Volume control should be at maximum and tone control to "low."

Connect a damping circuit comprising a 30,000-ohm resistance in series with a .05 mfd condenser between anode of V2 and chassis. Adjust T1 for maximum output on a signal of 465 kc fed into the control grid of V2.

Connect damping circuit between signal diode of V3 and chassis and adjust T2 for maximum output.

Inject a 465-kc signal into the control grid of V1 and connect the damping circuit between the anode of V1 and chassis. Adjust T3 for maximum output.

Connect damping circuit between control grid of V2 and chassis and adjust T4 for maximum output.

This method of trimming ensures a band-pass effect, and when the service oscillator is tuned over the 465 kc point, two peaks will be observed on the output meter.

SETTING UP BUTTON CIRCUITS.—The circuits may be set up by using a service oscillator and output meter in the usual way before making final adjustments on the stations.

To facilitate accurate setting up a high resistance voltmeter on a 60-volt range may be connected to the tags across R9. The action of the AVC on the anode current of the valve V2 will cause a variation in the voltage developed across R9 and a reading of approximately 60 volts will be obtained with no input (all buttons out).

The *minimum* reading obtainable as the adjustments are rocked over the station will indicate the true resonance point.

Connect an aerial and earth to the appropriate sockets, switch on the receiver and turn volume con-

* All buttons must be out when measuring this coil.

VALVE READINGS

V	Type	Electrode	Volts	Ma
1	TH4A (All valves Mullard)	Anode	265	3
		Screen	75	6
		Osc anode	75	4.5
		Cathode	1.5	—
2	VP4B	Anode	210	6
		Screen	120	2.5
		Cathode	—	—
3	TDD4	Anode	100	2.5
		Cathode	2.5	—
4	PenA4	Anode	245	27.5
		Screen	265	5
		Cathode	6.5	—
5	DW4/350	Anodes	345 AC	—

Pilot lamps, 6.2 volts, .3 amps, MES.
Readings taken with a 1,000 opv meter on 230 v mains with signal input, i.e., all buttons out.

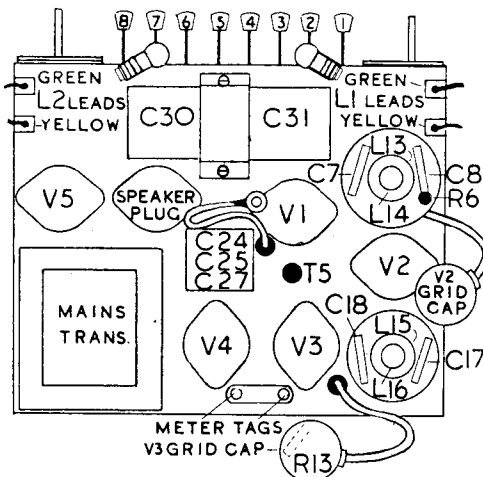
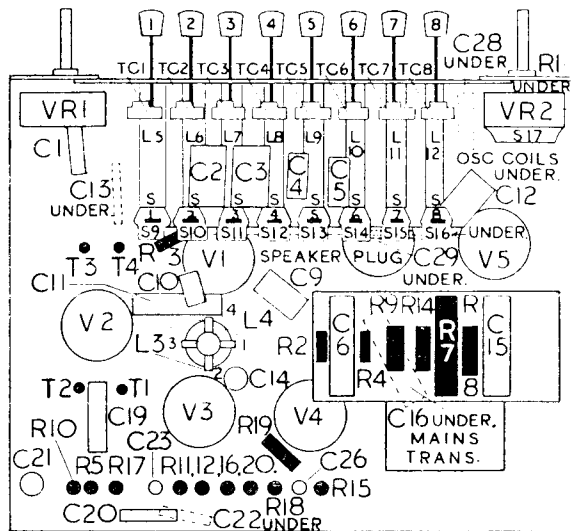

trol to maximum. Press the button allocated to the particular station and adjust the oscillator screw above the button so that the index mark coincides with the wavelength required. Carefully rotate this screw for loudest output and minimum reading on the voltmeter. Adjust the pre-selector trimmer below the button for maximum output or minimum reading on the voltmeter.

When replacing the frequency changer V1 it may be found necessary to reset the tuned circuits for which T5 is provided. Press the button appropriate to a station at the bottom end of the medium waveband (about 200 m), and adjust T5 until the station is correctly tuned; the remaining stations will then be automatically re-tuned.

FOR 100% DEPENDABILITY

In all capacities from 1pF to 10,000pF.

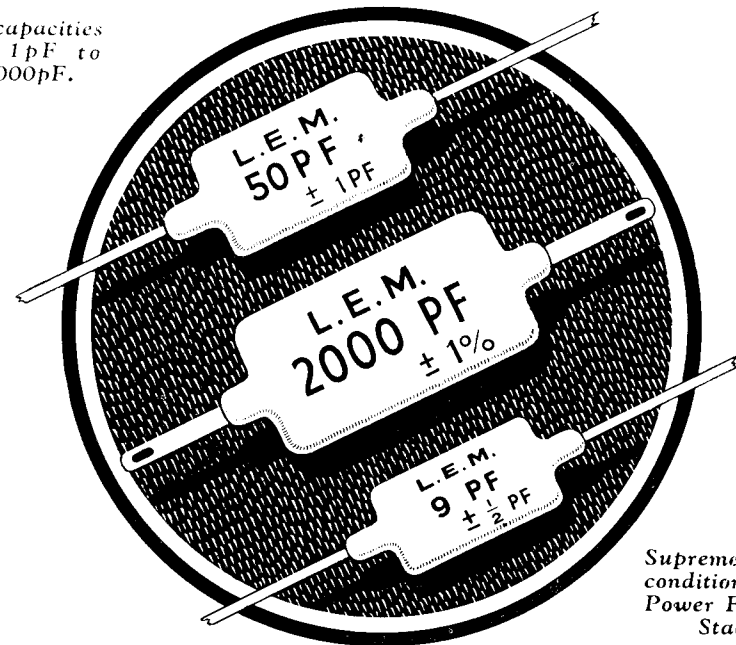

Supreme under all conditions for Low Power Factor and Stability.

THROUGHOUT the period of the war, L.E.M. Silvered Mica Condensers have been produced in vast quantities for the Services. They have given—and continue to give—complete satisfaction in every conceivable type of equipment on sea, on land and in the air. Their quality and adaptability commend them equally for world-wide peace-time use.

L.E.M.
SILVERED MICA
CONDENSERS

LONDON ELECTRICAL MANUFACTURING CO. LTD.
462, FULHAM ROAD, LONDON, S.W.10. 'Phone: FULham 4444.

AND HILLINGTON ESTATE, GLASGOW