

BUSH FOUR-V ALVE MAINS SUPERHET

Circuit.—The first detector oscillator valve, SP4 (V1) is preceded by a band-pass aerial coupling. Reaction is applied in the cathode circuit, and coupling to the I.F. valve is by tuned secondary transformer (frequency 123KC). The potential for the aux-grid is derived from a potentiometer common to V1 and V2, and each is properly decoupled.

The I.F. valve, VP4 (V2), has a stabilising resistance, R21, immediately in its grid

circuit. Volume is controlled by varying the bias through a variable resistance, R19, which also lowers the efficiency of the aerial coil. Coupling to the next valve is a band-pass intermediate transformer.

The second detector, 354V (V3), operates as an anode bend detector, and the pick-up jack is connected so that the output of the P.U. is fed to the grid through the secondary of I.F.T.2. The jack also connects the other pick-up lead to a point on the bias

potentiometer to allow the valve to work as a pure amplifier.

The anode circuit is decoupled from the H.T., and coupling to the output valve is by resistance capacity filter.

The output valve, PM24M (V4), is a directly heated pentode, and bias for it is derived from a potentiometer across the L.S. field which is in the negative H.T. lead.

(Continued on next page.)

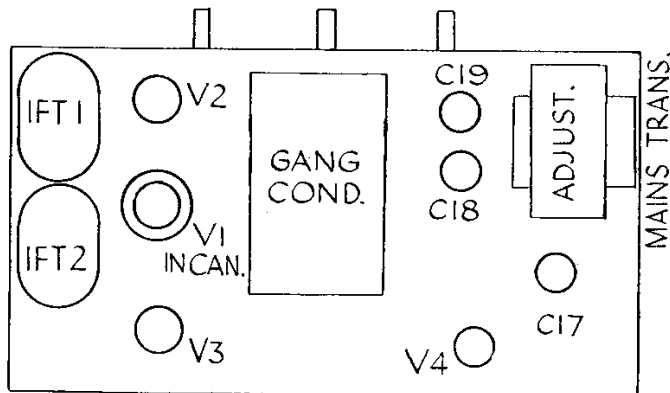

How the components and valves are arranged on the top of the S.A.C.4 receiver by Bush Radio, Ltd.

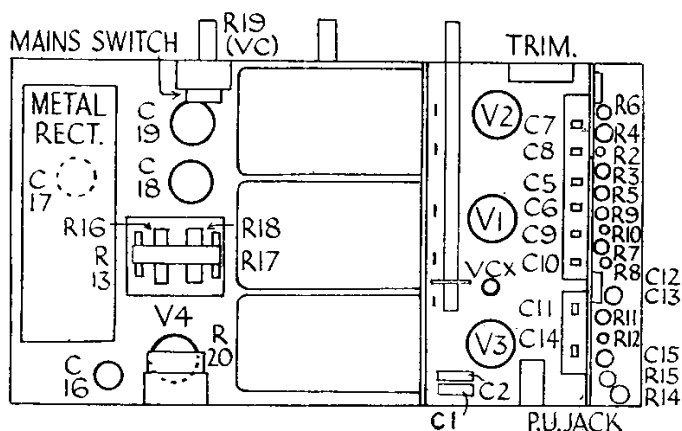

Compact grouping of the resistances and condensers is a feature of the below-chassis design of the Bush S.A.C.4.

RESISTANCES		
R.	Purpose.	Ohms.
1	V1 grid leak	.5 meg.
2	V1 aux. grid decoupling	.1 meg.
3	V1 anode decoupling	10,000
4	V2 aux. grid decoupling	10,000
5	V2 anode decoupling	10,000
6	V2 cathode bias	250
7	V3 anode decoupling	20,000
8	V3, V4, LF coupling	50,000
9	V3 cathode bias ptr.	1,000
10	V3 cathode bias ptr.	7,000
11	V4 grid leak	.5 meg.
12	V4 grid stabiliser	.1 meg.
13	V4 grid stabiliser	.1 meg.
14	Top part of aux. grid ptr.	10,000
15	Lower part of aux. grid ptr.	10,000
16	Part of bias ptr. across LS field	.5 meg.
17	Part of bias ptr. across LS field	.1 meg.
18	Decoupling grid circuit V4	.5 meg.
19	Var. vol. control, cathode V2	15,000 var.
20	Var. tone control, anode V4	20,000 var.
21	Grid stabiliser V2	250

CONDENSERS		
C.	Purpose.	Mfd.
1	Series aerial	.003
2	Suppressor circuit	.001
3	V1 grid condenser	.0005
4	Padding on LW of osc.	.0013
5	V1 aux. grid decoupling	.1
6	V1 anode decoupling	.1
7	V2 cathode	.1
8	V2 aux. grid decoupling	.1
9	V2 anode decoupling	.1
10	V3 cathode	.1
11	V3 anode decoupling	.5
12	V3 anode by-pass	.001
13	V3, V4 LF coupling	.005
14	V4 grid decoupling	.5
15	V4 grid, HF by-pass	.0003
16	Tone compensating anode V4	.06
17	HT smoothing	8 el.
18	Voltage doubler circuit	6 el.
19	Voltage doubler circuit	6 el.
20	Decoupling bias ptr.	.06

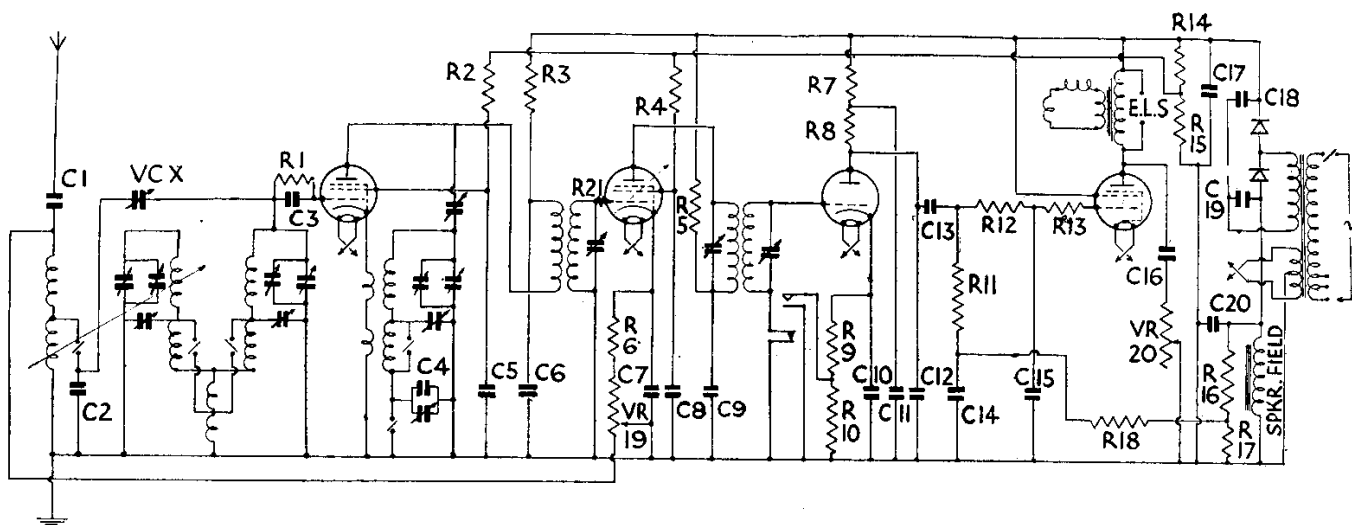

Detector-oscillator, intermediate-frequency, second detector and output pentode valves go to form the orthodox circuit of the S.A.C.4.

BUSH FOUR-VALVE MAINS SUPERHET (Cont.)

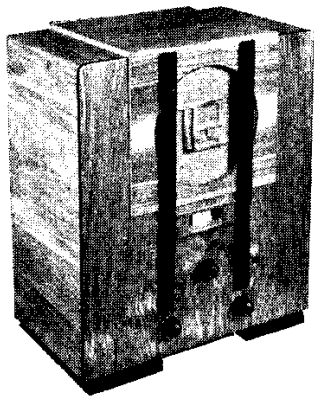

Bush Radio's S.A.C.A. is a good example of the modern, efficient four-valve superhet. It is a straightforward service proposition.

An H.F. stopper and a stabilising resistance with the necessary by-pass condenser, C15, are included in the grid circuit. Tone compensation is used with a fixed condenser in series with a variable resistance between the anode and earth.

Mains equipment consists of a transformer and a full-wave metal rectifier used as a voltage doubler with electrolytic doubler and smoothing condensers.

Quick Tests.—Between the rear terminals on the L.S. transformer and chassis:—

VALVE READINGS

Valve	Type.	Electrode.	Volts.	M.A.
1	SP4 ...	anode ...	240	.7
		aux. grid ...	60	—
2	VP4 ...	anode ...	217	2.4
		aux. grid ...	105	—
3	354V ...	anode ...	*	.2-.3
4	PM24M ...	anode ...	250	29
		aux. grid ...	265	4.5

* Anode bend detector, entirely erroneous readings may be obtained.

Top (F). Valve anode, 250 volts positive.
Bottom (K). H.T. smoothed, 265 volts positive.

Rear. Electrolytic condenser case, C18 (between mains transformer and gang condenser), 85 volts positive.

Front. Electrolytic condenser case, C19, 110 volts negative.

Removing Chassis.—Undo the knobs (grub screws). Remove four screws from underneath, loosen clip holding speaker leads and lift the chassis out.

General Notes.—Small components are mounted on two panels, the majority being on the long one at the end. The layout diagram indicates the positions the respective resistances and condensers occupy.

Switch contacts are open towards the outside and can be cleaned by a piece of tape.

The small ebonite former with the round-headed screw is the small condenser, VCX.

Replacing Chassis.—Slide chassis into cabinet. Replace four screws and clip the speaker leads. Replace knobs.

PYE P/A.C. FIVE-VALVE SUPERHET TRANSPORTABLE

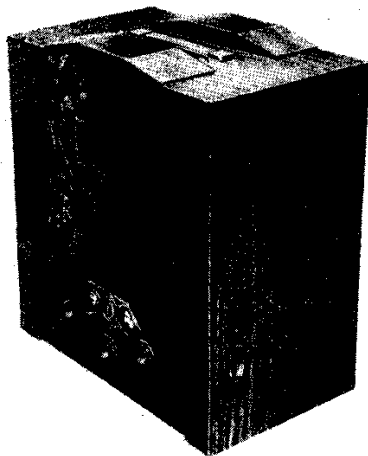

The P/A.C. by Pye Radio is a five-valve superhet with amplified and delayed A.V.C. and self-contained complete with a frame aerial.

Circuit.—An H.F. valve, VMS 4 (met.), (V1) is preceded by the tuned frame aerial, in which the long-wave winding is short circuited when the medium waves are required. The valve is biased from the A.V.C. system. Coupling to the next valve is by tuned anode coil with H.T. decoupling.

The combined first detector oscillator, ACS2/Pen (met.), (V2) uses anode-grid reaction with coupling through a coil in series with the cathode lead. Bias for this valve is fixed. The coupling to the I.F. valve is a band-pass I.F. transformer (frequency 114 k.c.).

The I.F. valve, a variable-mu, VMS4 (met.), (V3) has automatically controlled bias at the same potential as V1. Coupling to the second detector is by a second I.F. band-pass transformer, and the H.T. circuit is properly decoupled.

The second detector and I.F. valve is a double-diode triode, D.D.T. (plain), (V4). One diode anode is used for detection and the other provides bias for the A.V.C. system. Delay is obtained by biasing the anode itself from a potentiometer across the L.S. field which is in the negative H.T. lead.

The A.C. output is fed, with the rectified

D.C. to the variable potentiometer R13, which acts as an L.F. volume control. Coupling to the output valve is by resistance-capacity filter.

The output pentode, MPT4 (V5), is tone compensated by a resistance and condenser in series across the primary of the output transformer.

Mains equipment consists of:—Transformer, full wave voltage-doubler metal rectifier and the speaker field in the negative H.T. lead with two electrolytic condensers for smoothing.

Special Notes.—Amplified and delayed A.V.C.: As the D.C. potential developed across R13 increases, the bias on the grid of the triode section automatically decreases the anode current, and the voltage difference be-

For circuit, chassis layouts and component tables see next page.

tween the cathode and chassis decreases to a point at which the triode will function as an amplifier. This method provides amplified A.V.C. with delay action.

Quick Tests.—The L.S. transformer is inside the chassis, and the terminals are not accessible. Voltages between the following points and chassis:—

Positive end of rectifier (H.T. smoothed)+250 volts; case of middle electrolytic condenser (C37) -95 volts (voltage dropped across L.S. field and bias ptr.).

Removing Chassis.—Pull off control knobs. Withdraw the speech coil plug, the L.S. field coil plug and rectifier plug from their sockets. Remove valves.

Slacken the screws holding the valve screen and slide it out. Slacken the three screws holding frame aerial leads.

Undo the wood screws holding the mains

switch and the cleat holding the cable. Unwind the insulating tape and free the switch leads. Remove the two lower brackets for the door screws.

Remove four screws from underneath the cabinet and slide the chassis out.

Removing Rectifier (when necessary).—Remove four screws holding the box to top of cabinet and remove screws holding rectifier to box.

Removing Speaker.—First remove rectifier box. Undo the four wood screws holding the brackets to the sides of the cabinet and lift the unit out complete.

The frame aerial is fastened to the front of the cabinet by four screws on brackets.

General Notes.—If quavering reproduction resembling motor-boating is encountered, and a new D.D.T. does not cure it, the makers recommend replacing C24 (of .1 mfd.) by a larger one of .25 mfd. (non-inductive). The necessary condenser will be supplied free of charge if the serial number of the instrument is given.

Replacing Chassis.—Lay the chassis on the rubber supports, replace the four holding screws. Replace mains switch and clip the leads under the cleat.

Replace the L.S. field, speech coil and rectifier plugs and then the knobs. (The spring should be opposite the rounded side of the spindle.)

Chassis Support

Repairs to a receiver are greatly facilitated if some means is available for supporting the chassis in almost any position.

Probably the simplest idea lies in using two inverted T-shaped stands. The top of each T (actually the base piece) consists of a wood block about 18 in. long by 2 in. square. The upright member is just a light rod projecting from the centre of the bar.

When these brackets are placed on the bench so that the rods stick upwards, a chassis can be placed on them in almost any position.

If a series of notches is cut in the top of each base piece, it will be impossible for a chassis to slip.

VALVE READINGS

Valve.	Type.	Electrode.	Volts.	M.A.
1	VMS4 (Met.)...	anode ...	140	3.3
		screen ...	51	.9
2	AC/S2/Pen ...	anode ...	125	2.3
		aux. grid ...	116	1.4
3	VMS4 ...	anode ...	132	4
		screen ...	50	1.3
4	D.D.T. ...	Triode anode ...	127	3.9
		anode ...	172	26
5	MPT4 ...	aux. grid ...	180	4.4