

"TRADER" SERVICE SHEET
1133

WWW.COSSOR500,501.CO.UK

A.C. Mains "Melody Makers"



Appearance of the Cossor 501.

THIS version of the Cossor "Melody Maker," model 501, is the successor of a series of receivers bearing that name, the earlier A.C. versions being covered by *Trader Service Sheet 924*, and the A.C./D.C. versions being covered by *Service Sheet 1024*.

Model 501, on which this *Service Sheet* is based, is a 3-waveband, 4-valve (plus rectifier) transportable superhet designed to operate from A.C. mains of 200-255 V, 50 c/s.

Model 500 employs an identical chassis to that used in the 501, but it is housed in a wooden cabinet instead of a plastic one.

Release dates and original prices: Model 500, May, 1950, £15 2s 9d; Model 501, June, 1950, £12 19s 6d. Purchase tax extra.

CIRCUIT DESCRIPTION

Aerial input via L2 (S.W.) and common impedance coupler C1 (M.W. and L.W.) to single-tuned circuits L3, C27 (S.W.), L4, C27 (M.W.) and L5, C27 (L.W.). An internal aerial L1 is provided for use in areas of good signal strength and can be plugged into the A and E sockets.

First valve (V1, Cossor 62TH) is a triode hexode operating as frequency changer with internal coupling. Oscillator grid coils L6 (S.W.), L7 (M.W.) and L8 (L.W.) are tuned by C28. Parallel trimming by C30 (S.W.), C29 (M.W.) and C9, C29 (L.W.); series tracking by C8 (M.W.) and C8, C10, C31 (L.W.). Reaction coupling from anode via L9 (S.W.) and L10 (M.W. and L.W.).

Second valve (V2, Cossor 62VP) is a variable- μ R.F. pentode operating as intermediate frequency amplifier with tuned transformer couplings C4, L11, L12, C5 and C13, L13, L14, C14.

Intermediate frequency 470 kc/s.

Diode signal detector is part of double diode triode valve (V3, Cossor 62DDT). Audio fre-

quency component in rectified output is developed across volume control R9, which operates as diode load, and is passed via C17 to grid of triode section. I.F. filtering by C15, R7, C16.

D.C. component developed across R8 is fed back as bias to V1 and V2 giving automatic gain control.

Resistance-capacitance coupling by R11, C18 and R12 between V3 and pentode output valve (V4, Cossor 62PT). Variable tone control by R13, C19 and C20. Fixed tone correction by R17 and R18, which form a negative feed-back potential divider between winding c on T1 and V3 cathode circuit.

H.T. current is supplied by I.H.C. full-wave rectifying valve (V5, Cossor 66KU). Smoothing by R15 and electrolytic capacitors C21, C22. Residual H.T. hum is neutralized by passing the H.T. current through winding a on T1.

COMPONENTS AND VALUES

RESISTORS		Values	Locations
R1	Aerial shunt	1k Ω	A2
R2	V1 C.G.	330k Ω	G3
R3	V1 osc. C.G.	18k Ω	G3
R4	Osc. anode feed	33k Ω	G4
R5		12k Ω	F4
R6	S.G. pot. divider	33k Ω	G3
R7	I.F. stopper	47k Ω	F4
R8	A.G.C. decoup.	2.2M Ω	D3
R9	Volume control	500k Ω	D3
R10	V3 C.G.	4.7M Ω	E3
R11	V3 anode load	680k Ω	F3
R12	V4 C.G.	470k Ω	E3
R13	Tone control	500k Ω	E3
R14	V4 C.G. stopper	47k Ω	E4
R15	H.T. smoothing	2.7k Ω	E3
R16	V4 G.B.	180 Ω	E4
R17	Neg. feed-back pot.	470 Ω	F4
R18	divider	100 Ω	F4

CAPACITORS		Values	Locations
C1	Aerial coup.	0.005 μ F	A2
C2	L.W. aerial trim.	75pF	F3
C3	V1 C.G.	500pF	G3
C4	1st I.F. trans. tuning	100pF	A2
C5	ing	100pF	A2
C6	V1 osc. C.G.	100pF	F3
C7	A.G.C. decoupling	0.1 μ F	E3
C8	M.W. osc. tracker	440pF	F3
C9	L.W. osc. trim.	183pF	F3
C10	L.W. tracker	470pF	F3
C11	Osc. anode coup.	100pF	G4
C12	S.G. decoupling	0.1 μ F	F4
C13	2nd I.F. trans. tuning	100pF	B2
C14	ing	100pF	B2
C15		100pF	F4
C16	L.F. by-passes	100pF	E3
C17		100pF	E3
C18	A.F. coupling	0.005 μ F	E3
C19		0.1 μ F	E3
C20	Parts tone control	0.002 μ F	E3
C21*		100 μ F	E4
C22*	H.T. smoothing	32 μ F	A2
C23		16 μ F	E4
C24*	Tone corrector	0.005 μ F	E4
C25*	V4 cath. by-pass	25 μ F	E4
C26†	S.W. aerial trim.	—	G3
C27†	M.W. aerial trim.	—	G3
C28†	Aerial tuning	—	A1
C29†	Oscillator tuning	—	A1
C30†	M.W. osc. trim.	—	G3
C31†	S.W. osc. trim.	—	G3
C32†	L.W. osc. tracker	—	F3

* Electrolytic. † Variable. ‡ Pre-set.

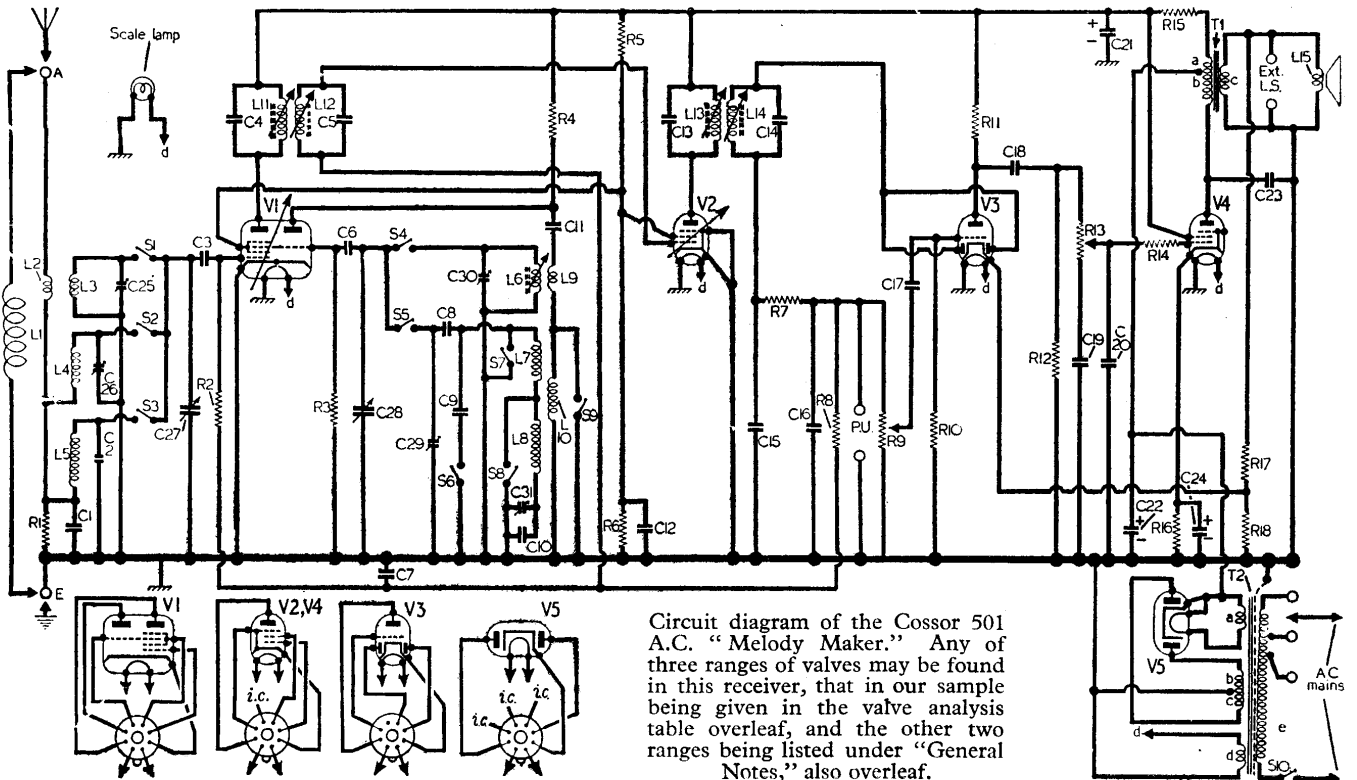

Circuit diagram of the Cossor 501 A.C. "Melody Maker." Any of three ranges of valves may be found in this receiver, that in our sample being given in the valve analysis table overleaf, and the other two ranges being listed under "General Notes," also overleaf.

OTHER COMPONENTS

		Approx. Values (ohms)	Locations
L1	Frame aerial	1.0	—
L2	S.W. aerial comp.	—	A1
L3	—	—	A1
L4	Aerial tuning coils	3.5	A1
L5		13.5	A1
L6		—	G3
L7	Oscillator tuning coils	2.8	F3
L8		7.5	F3
L9		2.6	G3
L10	Oscillator reaction coils	5.5	F3
L11		9.0	A2
L12		9.0	A2
L13	1st I.F. trans.	9.0	B2
L14		9.0	B2
L15	Speech coil	2.5	—
T1	O.P. trans.	13.0	B1
		280.0	
		—	
T2	Mains trans.	265.0	C2
		265.0	
		—	
		47.0	
S1-S9	Waveband switches	—	F3
S10	Mains sw., g'd R9...	—	D3

Plan view of the chassis. A "snap" fastener is used for voltage adjustments and is mounted on the mains transformer T2 in the location reference C2.

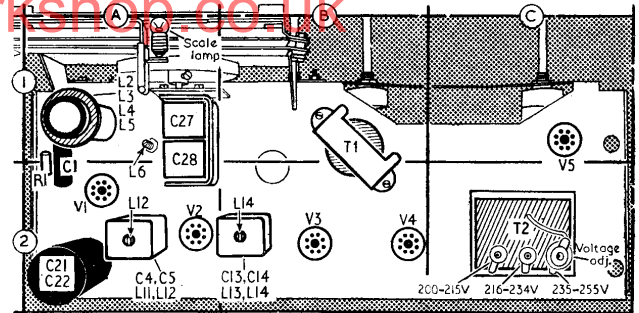

OM4; V4, 6V6GT; V5, 6X5G. With this range, R12 becomes 270 kΩ, R11 becomes 100 kΩ, R3 becomes 100 kΩ, R16 becomes 270 Ω and C18 becomes 0.01 μF.

Cossor Local Range: V1, 7S7; V2, 7B7; V3, 7C6; V4, 7C5 (or octal type 6V6GT); V5, 7Y4. With this range of valves R3 becomes 100 kΩ and R16 becomes 270 Ω.

M.W.—Switch receiver to M.W., tune to vertical line labelled "M.W." (or "M" in some receivers) at the top of tuning scale, feed in a 1.550 kc/s (193.6 m) signal and adjust C29 (G3) and C26 (G3) for maximum output. Repeat these adjustments.

L.W.—Switch receiver to L.W. and tune to line labelled "L" at top of tuning scale. Feed in a 160 kc/s (1.875 m) signal and adjust C31 (F3) for maximum output.

S.W.—Switch receiver to S.W., tune to vertical line labelled "S" at top left-hand side of tuning scale, feed in an 18 Mc/s (16.67 m) signal and adjust C30 (G3) for maximum output, choosing the peak involving the lower trimmer capacitance. Also trim C25 at this frequency for maximum output. Tune receiver to vertical line labelled "S" at the top right-hand side of tuning scale, feed in a 6 Mc/s (50 m) signal and adjust the core of L6 (A1) for maximum output. Tune receiver to "S" mark at the top left-hand side of tuning scale, feed in an 18 Mc/s (16.67 m) signal and readjust C30 and C25 for maximum output. Repeat these adjustments until no further improvement results.

GENERAL NOTES

Switches.—S1-S9 are the waveband switches, ganged in two rotary units beneath the chassis. The units are indicated in the under chassis illustration and shown in detail in column 2.

Switch Table

Switch	S.W.	M.W.	L.W.
S1	C	—	—
S2	—	C	—
S3	—	—	C
S4	C	—	—
S5	—	C	—
S6	—	—	C
S7	C	—	—
S8	—	C	—
S9	C	—	—

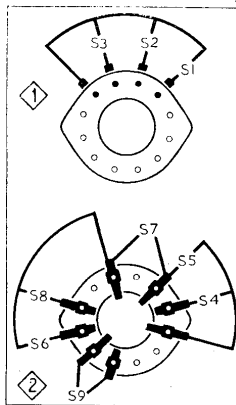

Diagram of the waveband switch units, drawn as seen from the rear of an inverted chassis. The associated switch table is on the left.

where they are drawn as viewed from the rear of an inverted chassis. The associated switch table appears above, where a dash indicates open and C closed.

Scale lamp.—This is a 6.5 V, 0.3 amp lamp, with a small spherical bulb and an M.E.S. base.

External Speaker.—Two sockets are provided at the rear of the chassis for the connection of a low-impedance (about 3 Ω) external speaker.

Drive Cord Replacement.—Forty inches of high grade flax fishing line is required for a new drive cord. It should be run as shown in the sketch (col. 3), where the drive system is drawn as seen from the rear of the chassis when the gang is at maximum.

Alternative Valve Ranges.—Both models 500 and 501 may use the following alternative ranges of valves.

Cossor Octal Range: V1, OM10; V2, OM6; V3,

CIRCUIT ALIGNMENT

I.F. Stages.—Switch receiver to M.W., turn gang to minimum capacitance and volume control to maximum. Connect signal generator (via an 0.1 μF capacitor in the "live" lead) to control grid (pin 6) of V1 and chassis. Feed in a 470 kc/s (638.3 m) signal, and adjust the cores of L14 (location reference B2), L13 (F4), L12 (A2) and L11 (G4) for maximum output. Repeat these adjustments until no further improvement results.

R.F. and Oscillator Stages.—With the gang set to minimum capacitance, the cursor should coincide with the vertical line labelled "MIN" at the top left-hand corner of the tuning scale. Transfer "live" signal generator lead to A socket, via a suitable dummy aerial.

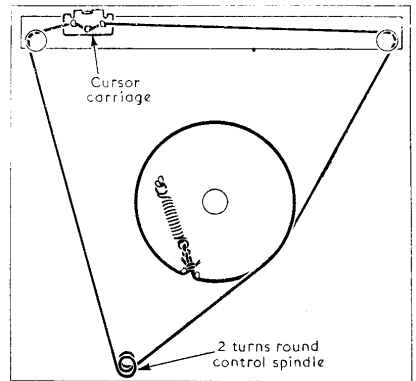

Sketch of the tuning drive system, drawn as seen from the rear of the chassis with the gang set at maximum capacitance.

VALVE ANALYSIS

Valve voltages and currents given in the table below are those derived from the manufacturer's information, and were measured with the receiver tuned to the highest wavelength end of M.W., but with no signal input. The receiver was operated from A.C. mains of 200 V, using the 200-215 V tapping on the mains transformer. Voltages were measured with a 1,000 ohms-per-volt meter, chassis being the negative connection in every case.

Valve	Anode		Screen		Cath.
	V	mA	V	mA	mA
V1 6Z1H	208	3.0	80	3.4	9.6
	Oscillator				
V2 6Z6P	196	3.2	80	2.3	12.3
	204	10.0			
V3 6ZDDT	46	2.0	—	—	2.0
V4 6ZPT	268	32.0	202	2.5	34.5†
V5 66K U	250*	—	—	—	58.0‡

*A.C., each anode. †Cathode voltage, 9V. ‡Cathode voltage, 280V.

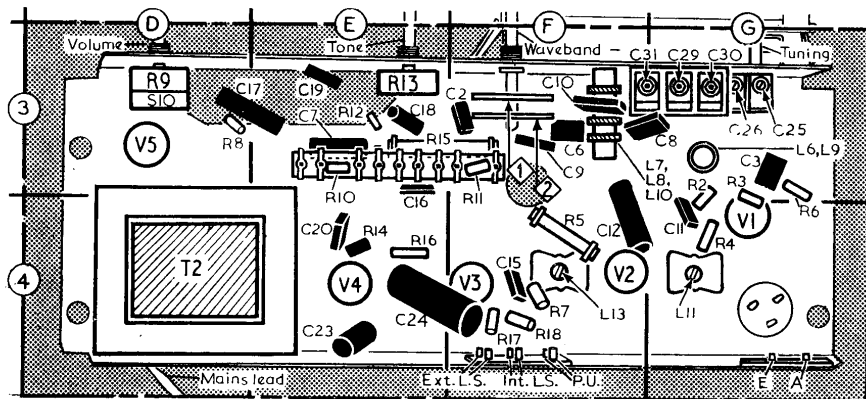

Under-chassis view showing all the R.F. and oscillator trimmers in location G3. The waveband switch units are indicated by numbers 1 and 2 in diamonds.