

DENCO DR22

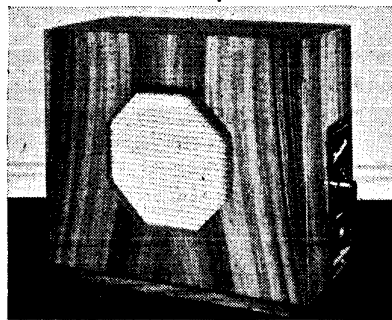

Four-valve superhet with five pre-set tuned channels selected by a rotary switch. Designed to operate on 200-240V AC-DC mains supplies. Walnut and sycamore or mahogany veneered cabinet. Made by Denco (Clacton), Ltd., 355-359 Old Road Clacton-on-Sea, Essex.

AERIAL is fed through isolating capacitor C1 to S1, and thence to coupling coils L2, L4, L6, L8 and L10. On positions 1 and 2 of selector switch S1 the aerial signal is fed to coils L2, L4 through an RF choke L1. Earth socket of receiver is isolated from the chassis by C24.

L3, L5, L7, L9 and L11 are the permeability-tuned grid coils and S2 connects them to fixed tuning capacitor C5, and through C4, to signal grid of triode-hexode frequency-changer V1. C2, C3 provide extra capacity on range 1 and 2. AVC is applied to g1 through R2 and is decoupled by R4, C6. Cathode is connected down to chassis. Screen voltage (g2, g4) is obtained from R1, which

Continued opposite

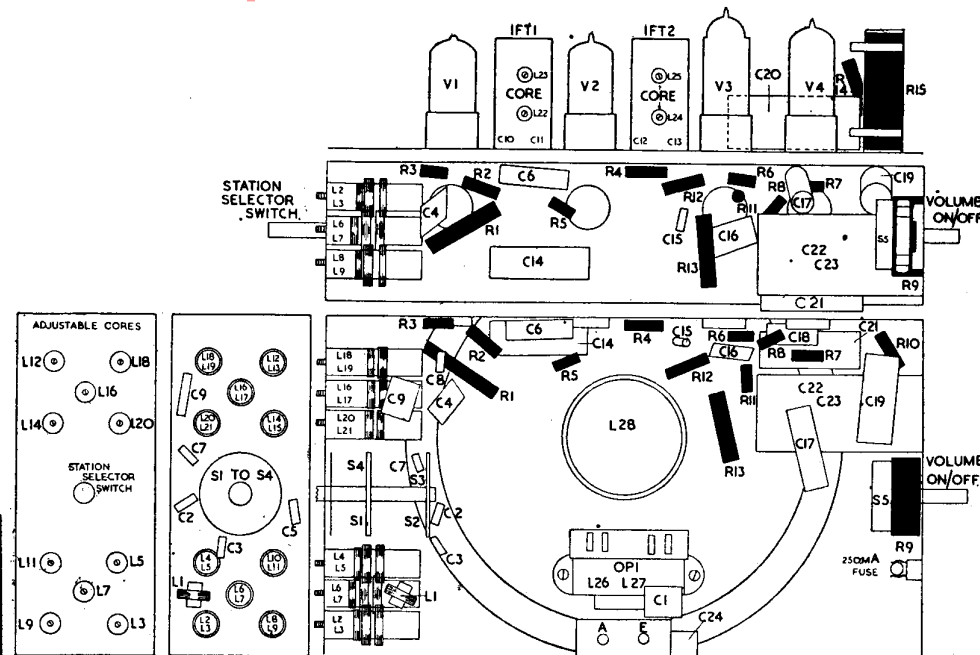

RESISTORS		Ohms		Watts	
R	Ohms	Watts	R	Ohms	Watts
1	22K	1	8	100K	1/2
2	1M	1	9	500K	Potr. with switch
3	47K	1/2	10	220	1/2
4	2M	1/2	11	100K	1/2
5	47K	1/2	12	2.2K	1/2
6	47K	1/2	13	500	3
7	220K	1/2	14	200	3
			15	1,250	12

INDUCTORS		Ohms	
L	Ohms	R	Ohms
1	28	8	1.5
2, 11, 20	3	9	4.5
3	4	10	1
4	21	11	7.5
5	4	12	1.5
6	18	13	8
7	2	14	1.5
		15	5
		16	1.3
		17	4
		18	1.1
		19	1
		20	8.5
		21	10
		22, 23, 24	350
		25	4
		26	2.5
		27	
		28	

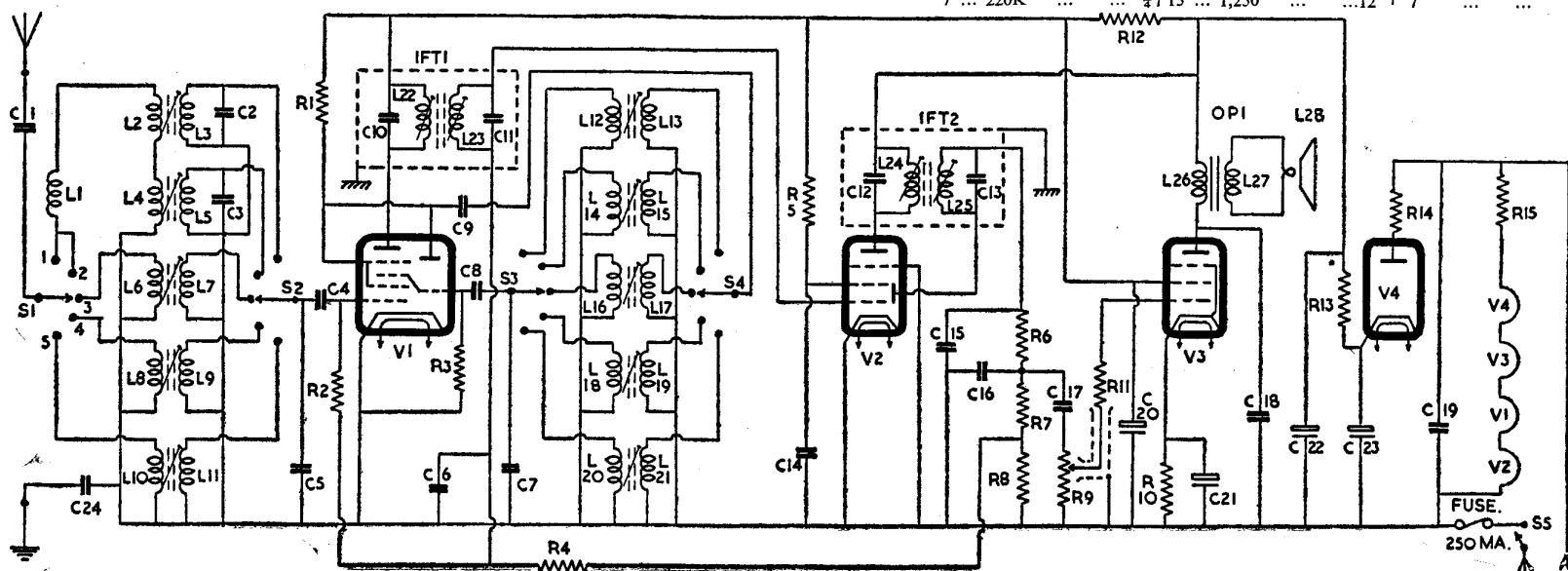
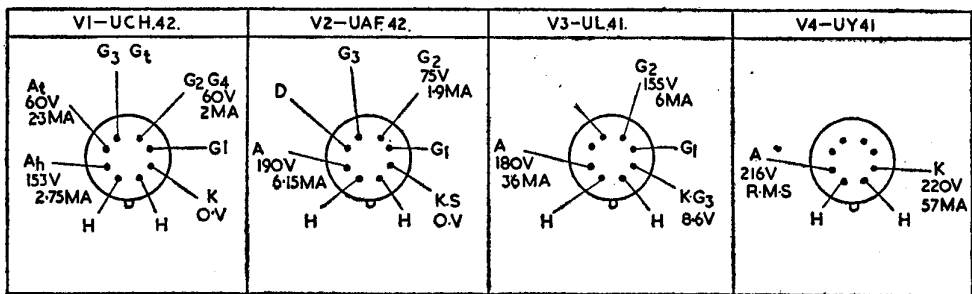

CAPACITORS

C	Capacity	Type
1	500pF	Silver Mica
2	200pF	Tubular C'mic
3	200pF	Tubular C'mic
4	250pF	Silver Mica
5	100pF	Tubular C'mic
6	.025	Tubular 350V
7	100pF	Tubular C'mic
8	50pF	Tubular C'mic
9	250pF	Silver Mica
10	100pF	
11	100pF	Tubular
12	100pF	Ceramic
13	100pF	
14	.1	Tubular 350V
15	50pF	Tubular C'mic
16	250pF	Silver Mica
17	.05	Tubular 350V
18	.001	Tubular 350V
19	.1	Tubular 500V
20	8	Electrolytic 350V
21	25	Electrolytic 25V
22	32	Electrolytic 350V
23	32	Electrolytic 350V

DENCO DR22

also provides oscillator anode (At) voltage of V1. L22, C10, which form the primary of IFT1, are in the hexode anode circuit.

Oscillator is connected in a tuned-grid parallel-fed circuit. L12, L14, L16, L18, L20 are the permeability-tuned coils which are connected by S3 to fixed tuning capacitor C7, and through C8 to oscillator grid of V1. Automatic bias for grid is developed on C8 with R3 as leak resistor. As each range is tuned to a specific frequency no tracking capacitors are required.

Anode reaction voltages are developed inductively by L13, L15, L17, L19, L21 and are fed by S4 through coupling capacitor C9 from oscillator anode. R1, which feeds screen, also functions as oscillator anode load.

IF amplifier operates at 465 kc/s. L23, C11, which form the secondary of IFT1, feed signal and AVC voltages to grid of RF pentode section of V2. R4, C6 decouple the AVC line.

Cathode of V2 is connected down to chassis. Screen voltage is obtained from R5 decoupled by C14 and suppressor grid is earthed to chassis. L24, C12, the primary of IFT2, is in the anode circuit.

Signal rectifier. L25, C13, which form the secondary of IFT2, feed signal to diode section of V2. R7, R8 form a tapped load resistor and R6, C15, C16 constitute an IF filter.

AVC is provided by the DC component of the rectified signal and is tapped off from junction of R7, R8 and is fed by R4 to grids of V1 and V2. C6 is decoupling capacitor.

Output stage. C17 feeds rectified signal to R9, the volume control, and thence, through stopper resistor R11, to grid of output pentode V3. Cathode bias is provided by R10 and decoupled by C21.

Screen voltage is obtained from R12 and decoupled by C20. L26, the primary of OP1, the output matching transformer, is in the anode circuit. C18 is a fixed tone correction capacitor.

TRIMMING INSTRUCTIONS

Apply signal as stated below	Tune Receiver to	Trim in Order stated for Max. Output
(1) 465 kc/s to g1 of V1 via .01mF ...	—	Core L25, L24, L23; L22
(2) 170—225 kc/s to AE E sockets via dummy aerial ...	Switch	Core L12, L3
(3) 190—260 kc/s as above ...	2	Core L14, L5
(4) 530—700 kc/s as above ...	3	Core L16, L7
(5) 740—1,000 kc/s as above ...	4	Core L18, L9
(6) 1.08—1.48 mc/s as above ...	5	Core L20, L11

(7) Finally check setting of cores on actual station signal and re-adjust if necessary

L27, the secondary of OP1, feeds into an 8 inch PM loudspeaker, L28.

High tension is provided by an indirectly heated half-wave rectifier, V4. Its anode voltage is obtained direct from the input mains. R14 is a current limiter and C19 a filter capacitor. R13, C22, C23 provide resistance capacity smoothing.

Heaters of V1 to V4 are series connected and obtain current of 100 mA from the mains through voltage dropper R15. S5, which is ganged to the volume control spindle, is the on-off switch.

A 250 mA fuse is inserted in the mains lead to chassis.

Chassis removal. Remove the two control knobs and rear panel of cabinet. Remove the two wood screws securing AE/E panel brackets to bottom of case. Unsolder leads to primary of OP1 on the loudspeaker.

Remove the two chassis bolts on underside of cabinet. Carefully press inwards the righthand side panel (viewed from rear) of chassis so that volume control spindle clears the side of cabinet, and withdraw chassis.

The manufacturers have allowed sufficient "play" in the wiring to avoid strain or damage to components when the righthand side panel of chassis is pressed inward.

PYE 18A—from page 24

the mains input transformer, supplies its anode voltages and L20 its filament current. Resistance-capacity smoothing is provided by R22, C27, C28.

Heaters of V1 to V3 and Dial Lights obtain their current from L22.

L23, the primary of MT1, is tapped for input voltages of 200-215, 216-235, 236-250 volts AC, 40-100 cycles.

S8, which is ganged to the tone control switch, is the ON/OFF switch.

Chassis Removal.—Remove back of set and pull off the four control knobs. Unclip SW aerial lead from top of cabinet and unplug loudspeaker leads. Remove the two chassis retaining screws located one at each end of rear side of chassis. Withdraw chassis approximately 2 in., tip up and lift out, taking care not to damage the frame aerial.

ATLAS UNITS—from page 25

bars ensure the retention of the bar in its final position. The end caps may now be fitted by the knurled screw.

Maintenance. Tubes are easily replaced by removing end caps of the fitting and detaching Crinothene diffusers. As tubes are in series, both go out when one fails.

Diffusers should be taken down and cleaned at regular intervals using warm soapy water but not applying heat when drying.

GRQ/2240, GSQ/2240. This is another twin 40W unit, electrically like the above, but with a different spine (Fig. 4) fitted with Perspex and Crinothene reflectors. It is for ceiling mounting, double or single rod suspension or chain suspension.

Perspex reflectors should be cleaned with warm soapy water, metal polish or Cirrasol. Wiping dry should be avoided as it accelerates collection of dust.

GB/2030, GA/3030, GAL/3030. The GB/2030 is illustrated in Fig. 5, the construction of the triple tube model (GA/3030) is shown in Fig. 6. GAL/3030 has louvres. The units are 4½ by 12½ by 6 in., and weigh 17 and 22 lb. respectively. Metal work is finished "Portland stone" and diffusers are Perspex.

Wiring. Fig. 7 shows the GB/2030 circuit and Fig. 8 the GA/3030 wiring.

Installation. The spines, which are similar, may be mounted directly to the ceiling, suspended on two rods, suspended from one rod with adaptor piece, or suspended from chains. The GA/3030 has a central reflector trough fitted by quick-release fasteners after the unit is mounted and the electrical connections made. The tubes are then inserted and the outer diffusing covers fitted and the end caps snapped into position. The GB/2030 is totally enclosed by a one-piece Perspex moulding. The white enamelled reflector plate is fitted by quick-release fasteners after the unit has been mounted and the electrical connections made. The tubes are then inserted and the Perspex moulding engaged over the diaphragm. End caps snap on.

FM/2080, FMQ/2080. These have similar construction to the GB/2030 with dimensions of 64 by 5½ by 12½ in., and weight of 32 lb.

Wiring.—The circuit for FM/2080 is seen in Fig. 7, and for the Quickstart version in Fig. 9.

Installation.—For direct ceiling fixing, four 3/16 in. diameter holes are provided in the main channel at 18-in. by 2-in. centres. If fixing rods are used, the ceiling plates provided should be fitted (assembled with the rods) at 18-in. centres. The main channel is then fixed by means of locknuts to the suspension tubes.

The mains are connected through the wiring entry to a two-way terminal block. Next the reflector plate is secured by two quick-release spring fasteners. The tubes are then inserted and tested.

The Perspex cover is fitted by sliding one end over the diaphragm so that its remote end can be raised upwards and then engaged over the other diaphragm. The cover should then be adjusted so that an equal amount protrudes past the diaphragms at each end. The end caps snap on.

FU/0030, FU/2030, FU/0080, FUQ/0080. These are all Perspex enclosed fittings of the general shape shown in Fig. 10.

Wiring. Circuits are FU/0030 and 0080 (Fig. 11), FU/2030 (Fig. 7) and FUQ/0080 (Fig. 12).

NOTE.—Compensated chokes in 30W circuits are set as follows: Mains Voltage 200—220V, Choke Setting 240—250; MV 230—240, CS 210—220 or 240—250 with special condenser; MV 250, CS 200—210. In 80W circuits: MV 200—210, CS 240—250; MV 200, CS 230—240; MV 230—240, CS 210—220; MV 250, CS 200.

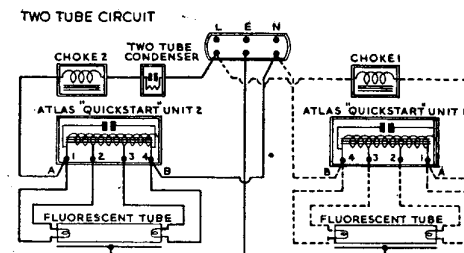

Fig. 9.—Quickstart twin 80W circuit

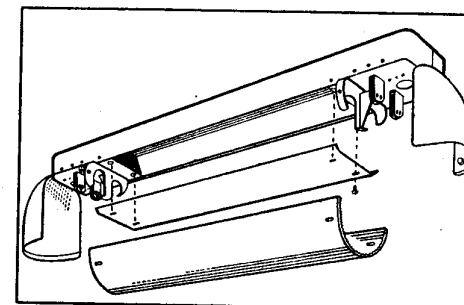

Fig. 10.—The FU 30 and 80W fittings

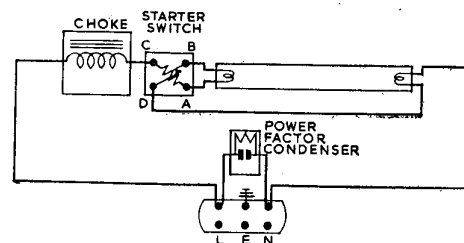

Fig. 11.—Single tube, 30 and 80W circuit

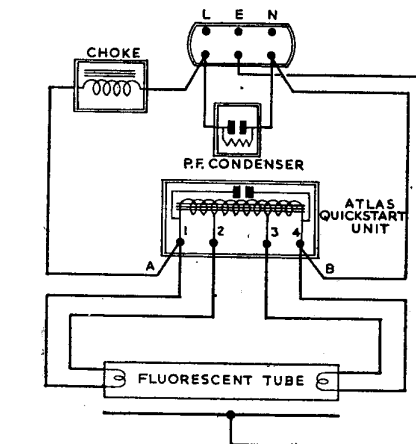

Fig. 12.—Quickstart single 80W circuit