

EMERSON RADIO & PHONOGRAPH CORP. MODELS CV264, CV280, CV295, CV298, CV313, CV314, CV316 Chassis CV (2 Types) Schematics

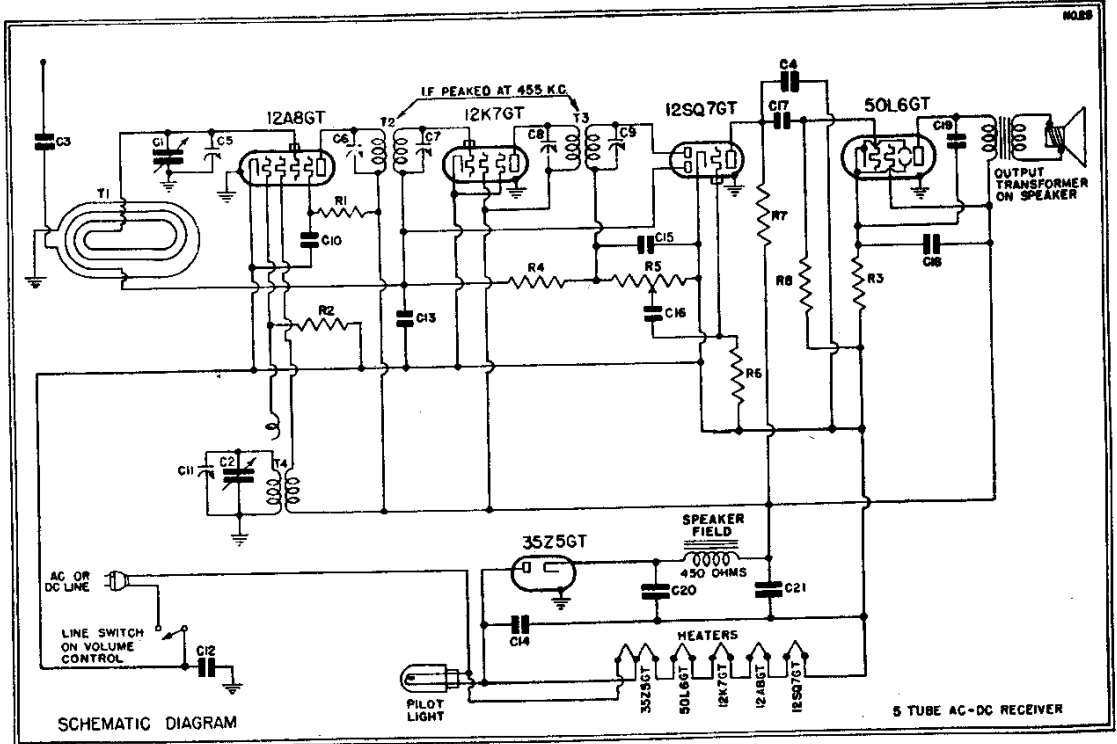

SCHEMATIC FOR CHASSIS USING 12A8GT TUBE

Voltage rating105-125 volts, a.c. or d.c.
Power consumption30 watts.

The color coding of the i-f transformer leads is as follows:
Grid—green Plate—blue
Grid return—black B plus—red

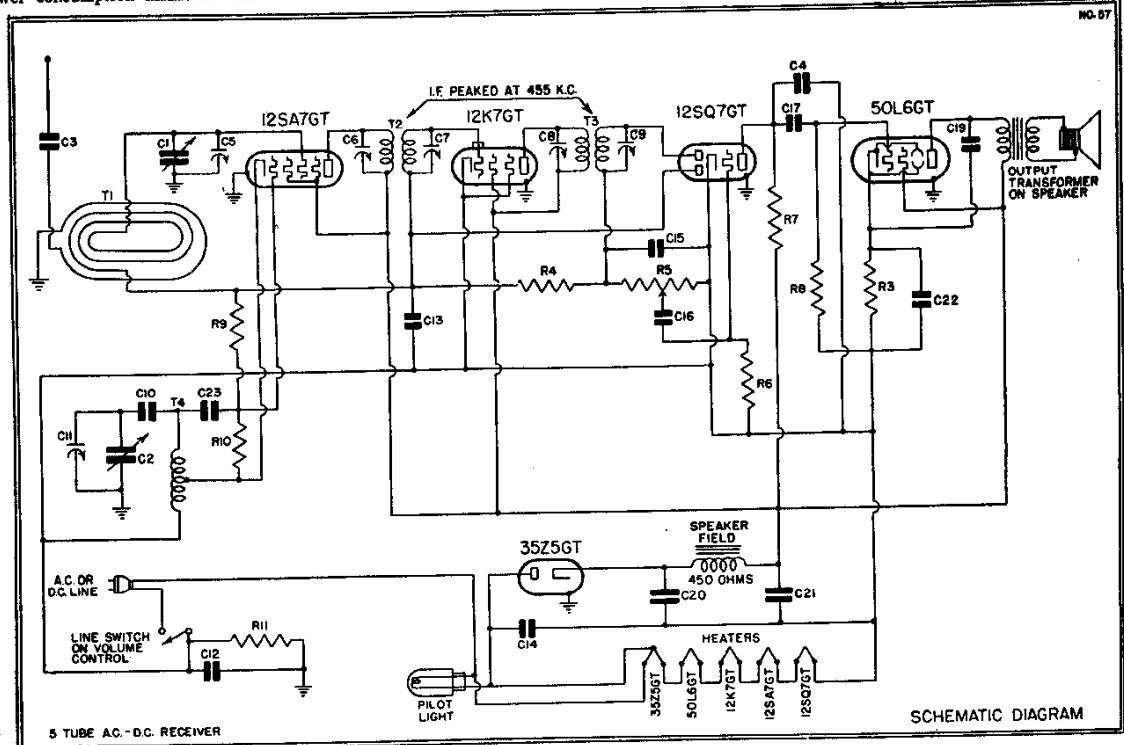

SCHEMATIC FOR CHASSIS USING 12SA7GT TUBE

MODELS CV264, CV280, CV295
 CV298, CV313, CV314, CV316 EMERSON RADIO & PHONOGRAPH CORP.

Chassis CV

Voltage, Parts, Changes

Alignment, Trimmers

TUBE DATA

THE TUBE COMPLEMENT IS AS FOLLOWS:

One 12SA7GT—pentagrid oscillator modulator
 One 12K7GT—first i-f amplifier
 One 12SQ7GT—diode detector, a-f amplifier, a.v.c.
 One 50L6GT—beam power output
 One 35Z5GT—half-wave rectifier

(NOTE: Chassis bearing serial numbers
 below 2920685 use 12A8GT instead of 12SA7GT)

VOLTAGE ANALYSIS

Readings should be taken with a 1000 ohms-per-volt meter. Voltages listed below are from point indicated to B minus (switch) with the volume control turned on full and no signal. Line voltage for these readings was 117.5 volts, 60 cycles, a.c. All readings except heaters and cathodes were taken on 250 volt scale. Measurements made with 117.5 volts d.c. will be lower than those given below.

Tube	Plate	Screen	Cathode	Fil.
†12SA7GT	88	88	0	12
12K7GT	88	88	0	12
12SQ7GT	40	—	0	12
50L6GT	82	88	5.7	50

Voltage at 35Z5 cathode—115 volts.

Voltage across pilot light—4.5 volts.

Voltage across speaker field—27 volts.

†Chassis using 12A8GT measures 88 volts at oscillator plate and 45 volts at screen.

*Item

Part No.

T1	6VW-172A	Loop antenna assembly (see production change no. 4b)		
T4	7BT-486A	Oscillator coil (see production change no. 2)		
T2	7BT-488C	Double-tuned 455 kc first i-f transformer (see production change no. 3a)		
T3	7FT-513D	Double-tuned 455 kc second i-f transformer (see production change no. 3b)		
R1	2CR-193	30,000 ohm ½ watt carbon resistor (see production change no. 1a)		
R2	KR-73	50,000 ohm ¼ watt carbon resistor (see production change no. 1a)		
R3	3FR-293	140 ohm ½ watt wire-wound resistor		
R4	NNR-220	3 megohm ¼ watt carbon resistor.	6JL-104	Pilot light, 6.3 volt, .15 amp., Mazda No. 47
R5	6VR-364	Volume control .25 megohm with line switch	6VD-82A	Dial face (see production change no. 4a)
R6	4XR-327	15 megohm ¼ watt carbon resistor.	4YZ-772	Drive cord
R7, R8	KR-56	500,000 ohm ¼ watt carbon resistor.	6JH-24B	Drive shaft
R10	LR-60	20,000 ohm ¼ watt carbon resistor (see production change no. 1b)	6RW-162	Drive cord spring
R11	LR-61	200,000 ohm ¼ watt carbon resistor (see production change no. 1b)	6RF-52	Dial pointer
C1, C2	6RC-436	Two-gang variable condenser	6RE-20	Dial crystal
C3, C16	3HC-274	0.002 mf, 600 volt tubular condenser		
C4, C15, C23	4XC-394A	0.00022 mf mica condenser		
†C5, C11		Trimmers, part of variable condenser.		
†C6, C7, C8, C9		Trimmers, part of i-f transformers.		
G10, G13	BC-12	0.05 mf, 200 volt tubular condenser		
C12	3CC-302	0.15 mf, 200 volt tubular condenser		
C14	LC-64	0.05 mf, 400 volt tubular condenser		
C17	6JC-425	0.024 mf, 400 volt tubular condenser		
C18	6VC-446	20 mf, 150 watt dry electrolytic condenser (see change no. 1a)		
C19	LC-65	0.02 mf, 400 volt tubular condenser (see change no. 3c)		
C20, C21	6JC-426B	Dual 20 mf, 150 volt dry electrolytic condenser		
C22	6ZC-460	20 mf, 25 volt dry electrolytic condenser (see change no. 1b)		
	6JS-268U	4" dynamic speaker		

DIAL PARTS

PRODUCTION CHANGES

- (a) Used only in chassis using 12A8GT.
 (b) Used only in chassis using 12SA7GT.
- (a) Chassis bearing serial numbers below 2764502 use oscillator coil 6RT-476
 (b) Chassis bearing serial numbers between 2764502 and 2920685 use oscillator coil 7CT-511
- Chassis bearing serial numbers below 2920685 use
 (a) First i-f transformer 6RT-479A.
 (b) Second i-f transformer 7BT-489A.
 (c) Condenser C19—.03 mf—400 volt.
- Chassis bearing serial numbers below 2764502 use
 (a) Dial face 6VD-82.
 (b) Loop antenna 6VW-172.

*Item number locates the article on the schematic diagram.

†Not supplied separately.

Location of Coils and Trimmer Adjustments

The first i-f transformer is mounted on top of the chassis deck to the left of the speaker. The trimmers are accessible through holes in the top of the can.

The second i-f transformer is mounted on top of the chassis to the right of the speaker. The trimmers are accessible through holes in the top of the can.

The trimmers for the antenna and oscillator coils are located on the variable condenser. The trimmer on the front section is for the antenna coil (loop). The oscillator coil is located directly beneath the speaker.

Alignment

I.F.—Swing the variable condenser to the minimum capacity position. Feed 455 kc to the grid of the 12SA7GT tube through a .01 mf condenser and adjust the four i-f trimmers for maximum response. The grid of the 12SA7GT tube may be reached by clipping the input lead to the stator loop of the antenna (front) section.

R.F.—Set the dial pointer at 140. Feed 1400 kc from the signal generator into a loop of wire about one foot in diameter. Hold this radiating loop about 12 inches away from and parallel to the receiver loop antenna. Advance the input to the loop until a satisfactory deflection is obtained on the output meter. Adjust first the oscillator trimmer (on rear section of variable condenser) then the antenna trimmer (on front section of variable condenser) for maximum response. If the loop antenna has been replaced it may be necessary to retrack the loop inductance. With the dial set at 60 feed 600 kc to the antenna lead. A portion of the outside may be swung to either side of the center to give maximum response. Repeat the trimmer alignment at 140.