

FERGUSON 203U

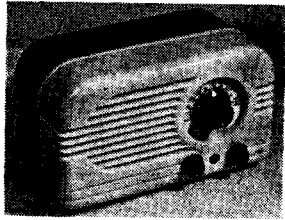

Five-valve two-wave band table superhet for 200 to 250 volt AC or DC mains. In compact moulded plastic cabinet of two sections. Made by Ferguson Radio Corporation Ltd., Great Cambridge Road, Enfield, Middlesex.

CIRCUIT consists of a triode-hexode frequency changer V1 coupled by capacity tuned air core transformer to a variable-mu RF pentode IF amplifier V2. A permeability tuned coil is used in the anode circuit of V2 and the IF signal is fed through a capacitor to a double-diode triode

V3 used for signal rectification, AVC and audio amplification. V3 is resistance-capacity coupled to the pentode output valve V4, from which the output is fed to a 5-inch PM speaker. On AC mains high tension is provided by an indirectly heated half-wave rectifier V5.

Aerial, consisting of approximately 4 feet insulated wire, is connected through isolating capacitor C1 to aerial coupling coils L1, L2 with R1 as a static drain across them. S1 shorts out L2 when on MW band. C2 is shunted across L2 on LW band. L3 (LW), L4 (MW) are aerial tuned coils switched by S2 to aerial tuning capacitor VC1 and to G1 of V1. T1 and T2 are trimming capacitors. AVC is fed to G1 through L3 and L4 from R4. C3 is AVC line decoupling capacitor. Cathode of V1 is at chassis potential. Screen voltage is obtained from R2 decoupled by C4. L8 and T7 form the primary of IFT1 in the hexode anode circuit.

Oscillator is connected in a tuned grid series fed HT circuit. L6 (MW), L7 (LW) are tuned coils switched by S3 to oscillator tuning capacitor VC2 and through C5 to oscillator grid (Gt, G3h) of V1. T3, T4 are trimmers and T5, T6, together with fixed capacitors C6, C7, are padders. S4 shorts the LW coil L7 when set is operating on MW band. Reaction voltages for both wavebands are developed inductively on L5, which is connected in series with HT supply to oscillator anode (At).

Continued overleaf

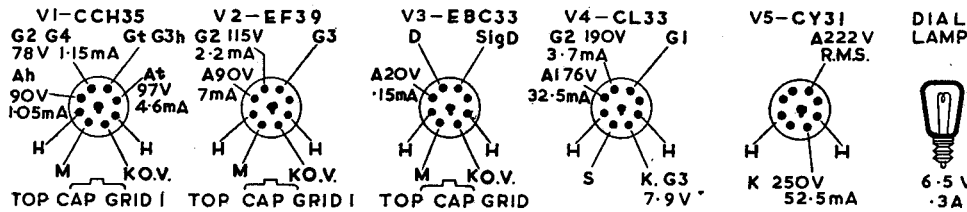

RESISTORS

R	Ohms	Watts
1	50K	1W
2	33K	1W
3	47K	1W
4	2.2 Meg	1W
5	100K	1W
6	500K Potr. with D.P.	1W
7	680K	1W
8	6.8 Meg.	1W
9	680K	1W
10	4.7K	2W
11	220	1W
12	1.2K	6W
13	100	1W
14	700 3 core line cord.	1W
15	10K	1W

CAPACITORS

C	Mfds	Type
1	250 pf silver mica	
2	150 pf silver mica	
3	.02 tubular 500V	
4	.02 tubular 500V	
5	100 pf silver mica	
6	400 pf silver mica	
7	100 pf silver mica	
8	.02 tubular 500V	
9	100 pf silver mica	

Continued end column

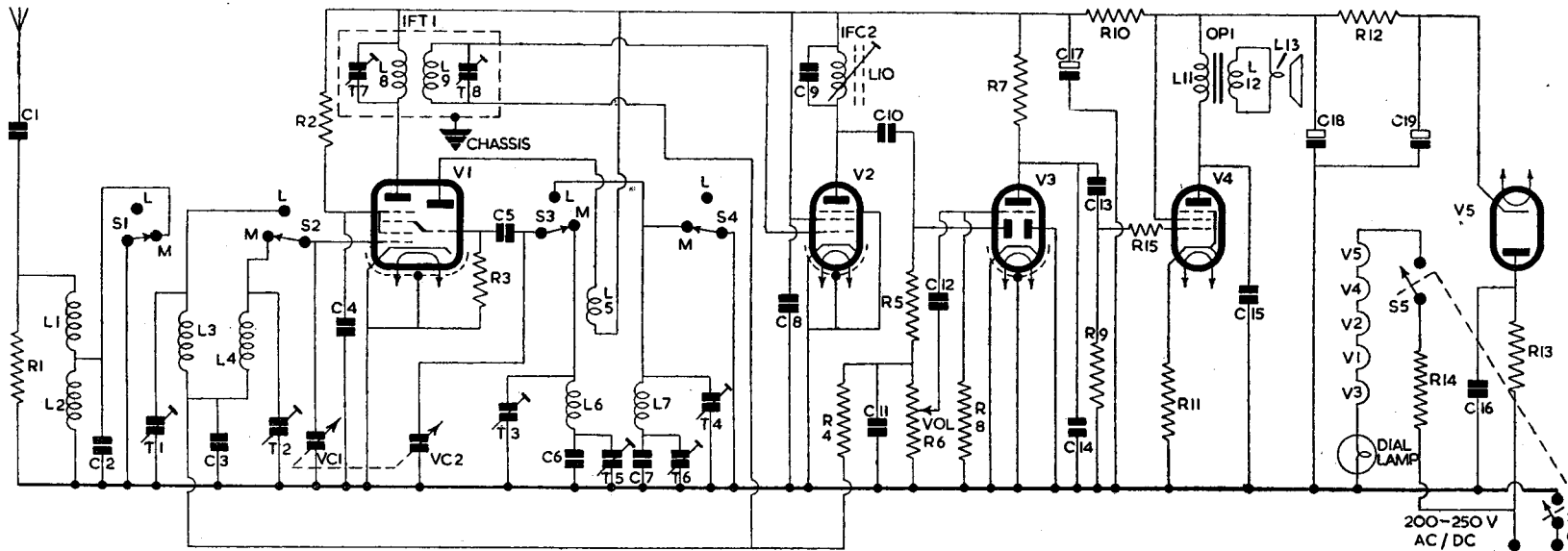
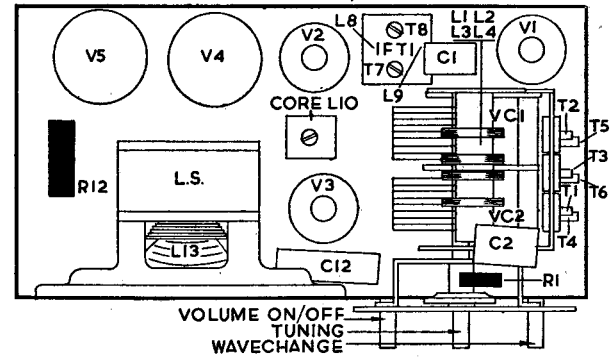
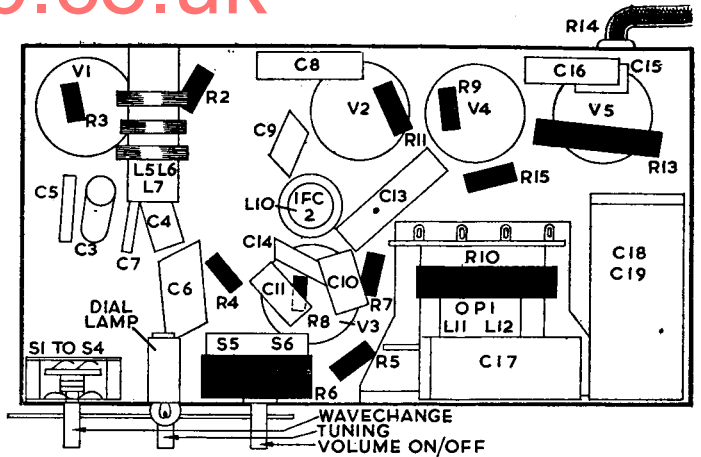

CAPACITORS—contd.

C	Mfds.	Type
10	100 pf silver mica	
11	100 pf silver mica	
12	.05 tubular 500V	
13	.05 tubular 500V	
14	100 pf silver mica	
15	.005 tubular 500V	
16	.02 tubular 500V	
17	4 electrolytic 350V	
18	16 electrolytic 350V	
19	16 electrolytic 350V	

INDUCTORS

L	Ohms
1	23
2	38
3	29
4	4
5	2.5
6	2.25
7	5.5
8	9.5
9	8.5
10	7
11	450
12	.6
13	2.5

FERGUSON 203U—Continued

IF Amplifier operates at 455 kc/s. L9, T8, the secondary of IFT1, feeds signal to G1 of V2, the variable-mu IF amplifier valve. AVC voltage is fed to grid through secondary of IFT1. Cathode is at chassis potential. Screen voltage is obtained from HT line to V1 and V3 decoupled by capacitor C8. A single tuned circuit consisting of a permeability tuned coil L10 and capacitor C9 is used in the anode circuit of V2.

Signal Rectifier. C10 passes IF signal to one diode of V3. R6, the volume control, is the diode load and R5 with C11 filter out the IF component of the signal.

Automatic Volume Control is taken from the signal diode through R4 to grids of V1 and V2 decoupled by C3. Cathode is at chassis potential, hence no delay voltage for the AVC line is provided. The second diode of V3 is connected down to chassis.

AF Amplifier. C12 feeds signal from volume control R6 to grid of triode section V3. R8 is its grid leak and bias is developed on C12. R7 is the anode load and C14 RF bypass capacitor.

Output Stage. C13 feeds signal at anode V3 to G1 of pentode output valve V4. R15 is grid stopper and R9 grid resistor. R11 provides cathode bias and as no decoupling capacitor is fitted there is a degree of negative feedback applied at this stage. Screen (G2) voltage is obtained from main HT line. L11, the primary of output matching transformer OPI, is in the anode circuit of V4. C15 is for tone correction. L12, the secondary of OPI, feeds into a 5-inch PM speaker L13.

High Tension is provided on AC mains by an indirectly heated half-wave rectifier V5. Its anode voltage is obtained from mains supply through limiting resistor R13. C16 eliminates modulation hum. R12, C18, C19 provide resistance-capacity smoothing of the HT and screen supply to V4. R10 is a voltage dropper for HT supply to V1 to V3 with C17 for decoupling.

Heaters of V1 to V5 and Dial Lamp are in series, obtaining their current through dropping resistor R14. S5, S6, the ON/OFF switches, are ganged and controlled by spindle of volume control.

To expose chassis. Remove the two small control knobs by completely withdrawing their self-threading screws. Remove the two bolts (with washers) located in recesses at the top left and right corners of the rear cabinet moulding. Remove the four padded feet (pull off) from the case of the cabinet. Remove the four double-ended chassis retaining screws (with lock washers) from the underside of the cabinet, and draw apart the two sections of the cabinet to expose the chassis.

When reassembling, see that the longer threads of the double-ended chassis retaining screws are used to secure the chassis to the base of the cabinet, and that a lock washer fits under each head. The shorter threads of these screws take special transit caps to hold a protective wooden batten across the base of the moulded casing, which should be replaced if the set is transported. In use, felt-padded feet take the place of the caps.

One felt washer should be placed between each small control knob and the front of the cabinet, and the retaining screws must be covered with a suitable insulating compound.

NOTE.—Three versions of this receiver, identified by the valves used, have been produced. The only circuit differences are listed as follows.

Type 1

- Brimar Valves :** V1—12K8GT
V2—12K7GT
V3—12Q7GT
V4—35L6GT
G5—35Z4GT

- L.1 —Single primary coil common to both bands.
R.1 —220,000 ohms.
R.15—Deleted.
R.14—800 ohms.
Screen of V4 connected to the junction of R7 and R10.
R.11—shunted by 25 mF electrolytic.

Type 2

- Mullard "Red E" Valves :** V1—CCH.35
V2—EF.39
V3—EBC.33
V4—CL.33
V5—CY.31

- L.1 —Single primary coil common to both bands.
R.1—220,000 ohms.

Type 3

Details according to this Service Sheet.

TRIMMING INSTRUCTIONS

Apply Signal as Stated Below	Tune Receiver to	Trim in order stated for Max. Output
(1) 455 kc/s to top cap V1 via .01 capacitor. (Remove existing connector to tap cap and connect 100k resistor between grid and chassis).	LW band with gang and volume in max. position.	Core, L10, T8, T7.
(2) Check dial pointer —with gang at max. capacity pointer should coincide with dividing lines between MW and LW calibration scales.		
(3) 1.42 mc/s to Aerial lead via dummy aerial.	214 metres	T3, T2.
(4) 600 kc/s as above.	500 metres	T5. Repeat 3 and 4.
(5) 400 kc/s as above	750 metres	T4, T1.
(6) 150 kc/s as above	2000 metres	T6. Repeat 5 and 6.

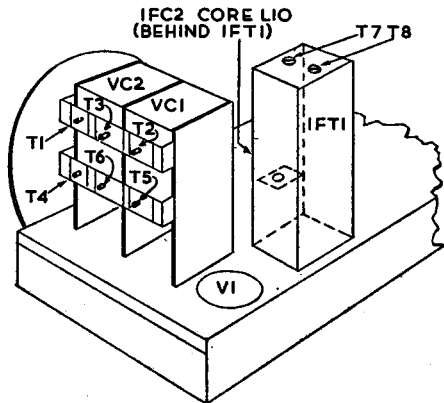

Immediate delivery

METERS at PRICES BELOW PRESENT DAY COST

Panel-mounting moving-coil meter illustrated is in Black Bakelite case, 2 1/4" x 1 1/2". 0-40 volts.

Also available are :

- Voltmeter 2 1/4" x 1 1/2" 0-20 Volts.
- Voltmeter 2 1/8" x 1 1/2" 0-600 Volts.
- Milliammeter 3" x 1 1/4" 0-50 M.A.
- Milliammeter 1 1/2" x 1 3/8" 0-75 M.A.
- Ammeter 2 1/4" x 1 7/8" 50-0-50 Amp.
- Oil Pressure Gauge 2 1/4" x 2 1/2" 0-160 lbs.

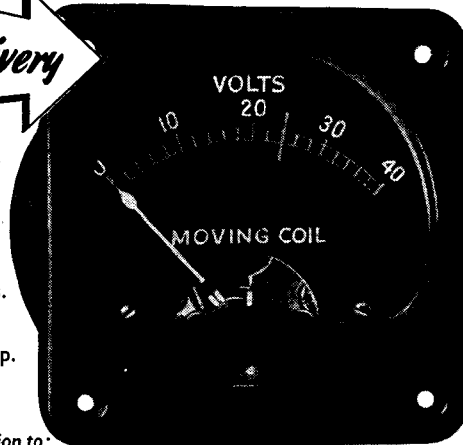

Illustrated folder and trade prices on application to:

PIFCO LTD. · PIFCO HOUSE · WATLING ST. · MANCHESTER, 4

**FOR ALL TIME
STURDY
REWINDS
SATISFACTION**

Send your rewinds to Sturdy. All makes Radio Mains Transformers, Field Coils, etc. First-class work with quick delivery and fully guaranteed.

STURDY ELECTRIC CO., LTD.
DIPTON Tel.: DIPTON 221 NEWCASTLE-ON-TYNE



For all **SOLDERING** work you need **FLUXITE** —the paste flux—with which even dirty metals are soldered and "tinned." For the jointing of lead—without solder and the "running" of white metal bearings—without "finning" the bearing. It is suitable for ALL METALS—excepting Aluminium—and can be used with safety on Electrical and other sensitive apparatus. With **FLUXITE**, joints can be "wiped" successfully that are impossible by any other method. Of ALL IRONMONGERS, in tins—10d., 1/6 & 3/- Used for over 40 years in Government works and by leading Engineers and Manufacturers. "The **FLUXITE GUN**" puts Fluxite where you want it by a simple pressure. Price 1/6 or filled 2/6.

FLUXITE
SIMPLIFIES ALL SOLDERING

Write for Leaflets on Case-Hardening Steel and Tempering Tools with **FLUXITE**, also on "Wiped" Joints. Price 1d. each. **FLUXITE LTD., (Dept. T.E.), Bermondsey St., London, S.E.1.**