

# FERGUSON

RADIO

[www.radio-workshop.co.uk](http://www.radio-workshop.co.uk)



RECORD  
PLAYER

392G

*'Fam'*

# SERVICE MANUAL

INITIAL COPY ISSUED FREE TO FERGUSON ACCREDITED DEALERS

ADDITIONAL  
COPIES 9d.

# RECORD PLAYER

## MODEL 392 G

### SPECIFICATION

**Mains Supply :** 200-250 Volts 50 cps AC mains.

**Power Consumption :** Approximately 30 Watts at 240 Volts.

**Valves :** Triode pentode UCL83 and rectifier UY85.

**Output Power :** Approximately  $1\frac{1}{2}$  Watts.

**Turntable :** BSR four speed type TU9.

**Pick-up :** BSR type TC8M turnover crystal.

**Loudspeaker :** 7in. x 4in. elliptical.

**Case :** 15 in. wide x  $16\frac{1}{2}$  in. deep (including handle) x  $7\frac{1}{2}$  in. high.

### CIRCUIT

The amplifier circuit utilises a triode pentode valve type UCL83; the triode section forming the audio amplifier and the pentode section the output stage. The volume control R2 operates in the grid circuit of VIA the audio amplifier and a negative feedback type tone control is employed. The negative feedback voltage is obtained from VIB a node circuit through C3 and the tone control R5 and injected in VIA cathode circuit across R4. With the tone control turned fully anti-clockwise, C5 is not included in the feedback circuit but, as the control is turned clockwise, C5 increases the feedback at the higher frequencies and so reduces the treble response of the amplifier. The value of C3 has been chosen to give a measure of bass boost.

The heater supply for the UCL83 and the HT rectifier UY85, connected in series, is obtained from a tapping on the stator winding of the turntable motor.

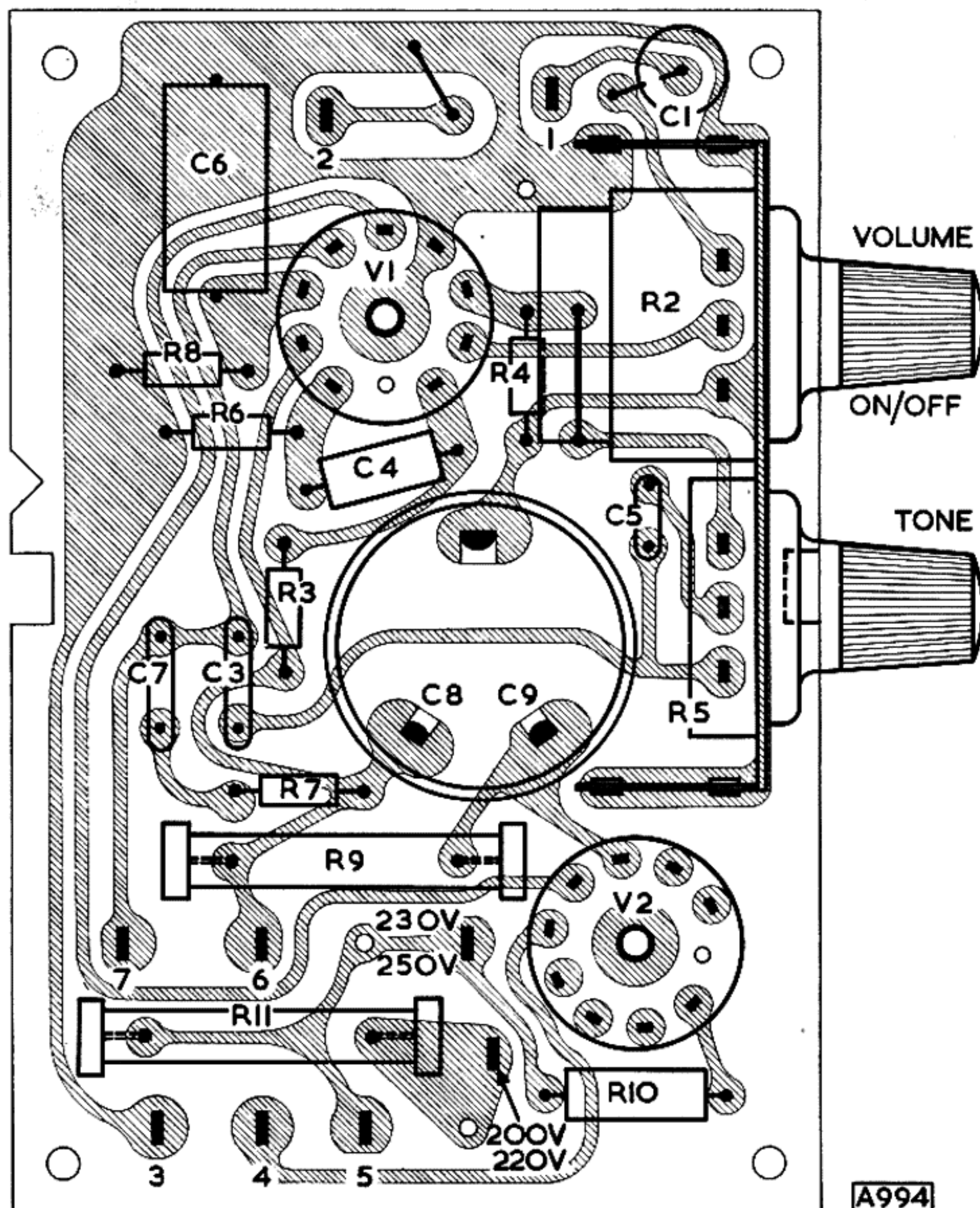

Fig. 1. Printed circuit panel viewed from the components side.

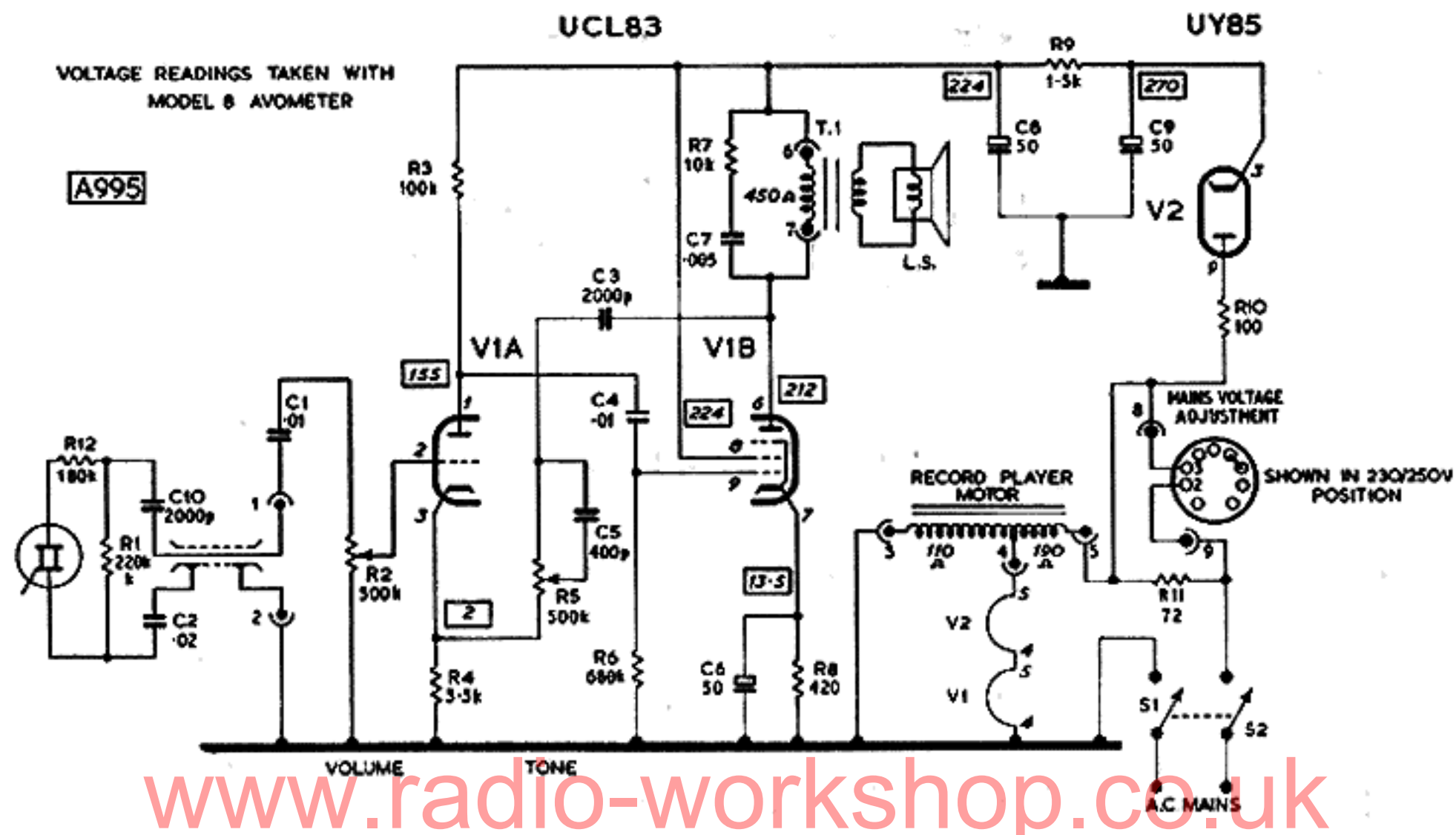

Fig. 2. Circuit diagram. Voltage measurements, shown in rectangles, were taken with a model 8 Avometer with a mains input of 235 Volts AC (50 cycles) and the voltage adjustment set to 230—250 V.

Note: In some models R1 is 330K $\Omega$  and R12 120K $\Omega$ . R12 and C10 were not fitted in early production and R1 was then 470K $\Omega$  10%.

Later Production: R4 is 2.2 K $\Omega$  in some cases.

## RESISTORS

All carbon type unless otherwise stated. Where no tolerance or power rating is given for fixed resistors, these should be taken as  $\pm 20\%$  and  $\frac{1}{4}$  Watt respectively.

Ref.	Value	Rating	Function
R 1	220K $\Omega$	10%	Pick-up shunt
R 2	500K $\Omega$	Carbon pot. log.*	Volume control
R 3	100K $\Omega$		V1A anode load
R 4	3.3K $\Omega$		V1A cathode bias
R 5	500K $\Omega$	Carbon pot. lin.*	Tone control
R 6	680K $\Omega$		V1B grid leak
R 7	10K $\Omega$		Tone correction
R 8	420 $\Omega$	10%	V1B cathode bias
R 9	1.5K $\Omega$	10%	HT smoothing
R 10	100 $\Omega$	10%	Rectifier current limiter
R 11	72 $\Omega$	5%	Mains dropper
R 12	180K $\Omega$	10%	Pick-up series

\*Part No. of panel incorporating both controls—Y13086.

## CAPACITORS

Electrolytics excepted, tolerance  $\pm 20\%$  unless otherwise stated. Where no working voltage is given, this should be taken as 350 Volts DC.

Ref.	Value	Rating	Function
C 1	.01 $\mu$ F	300V AC	Pick-up isolating
C 2	.02 $\mu$ F	300V AC	
C 3	2000pF	500V	NFB bass boost
C 4	.01 $\mu$ F		V1B CG coupling
C 5	400pF		Tone control
C 6	50 $\mu$ F	Electro* 25V	V1B cathode bypass
C 7	.005 $\mu$ F	500V	Tone correction
C 8	50 $\mu$ F	Electro† 275V	HT smoothing
C 9	50 $\mu$ F	Electro† 275V	HT reservoir
C 10	2000pF	500V	Pick-up series

\*Part No. Y13210/4.

†Part No. Y13200.

## MISCELLANEOUS

Ref.	Function and Description	Part No.
L.S.	7in. x 4in. elliptical loudspeaker, 3 ohm speech coil	Y16011/3
S1 } S2 }	Mains On-Off switch (ganged with R5)	Part R5
T1	Output transformer	Z17909

The manufacturers reserve the right to vary specifications or use alternative materials as may be deemed necessary or desirable at any time.

## SERVICING NOTES

When servicing becomes necessary on the printed circuit panel, it must be remembered that excessive heat can loosen the bond between the copper conducting circuits and the insulating board; consequently, particular care is necessary if any connections must be made to the "wiring" side of the board. For this reason, when replacing a resistor or capacitor, cut out the faulty component so that as much as possible of the original lead-out wires remain for connecting in the new component, soldering

to the ends of the wires instead of to the printed conductors. Use a small low consumption iron and do not apply the bit for longer than is necessary to produce a sound joint.

The heavier components are secured to the panel by clip lugs which also form the electrical connections. To remove these, use a heavier type iron and apply heat and pressure to the lug—not the printed circuit—so that when the solder melts, the lug is pressed clear of the connecting

point. In some cases a small stiff-haired brush will assist in breaking the connection.

When a section of printed conductor is damaged or fused, scrape off the damaged portion and restore the connection with a jumper wire on the component side of the board. Should it become necessary, however, to solder directly to a printed conductor, use a 60/40 resin cored solder and, with a low consumption iron, make the joint quickly to avoid overheating. Do not use a corrosive type flux.

## MECHANICAL DETAILS

### Dismantling

To remove the motor board, withdraw the screws at each side of the board and, in addition the two screws securing the front ventilation panel. This panel may then be prised out, making use of the slot at the top. Lift up the motor board and remove the socket lead connectors from the printed board. The motor board may then be lifted out of the case.

The amplifier unit is secured by a woodscrew at each corner of the panel.

### Stylus Replacement

When replacing a worn stylus, use the following types:—

LP—TC8R (coloured red).

78—TC8G (coloured green).

Do not remove the screw securing the stylus, one turn is sufficient to slacken and so enable the stylus to be withdrawn. When fitting the new stylus, ensure that the stylus is correctly seated under the screw at one end and fitting over the stylus coupler at the other.

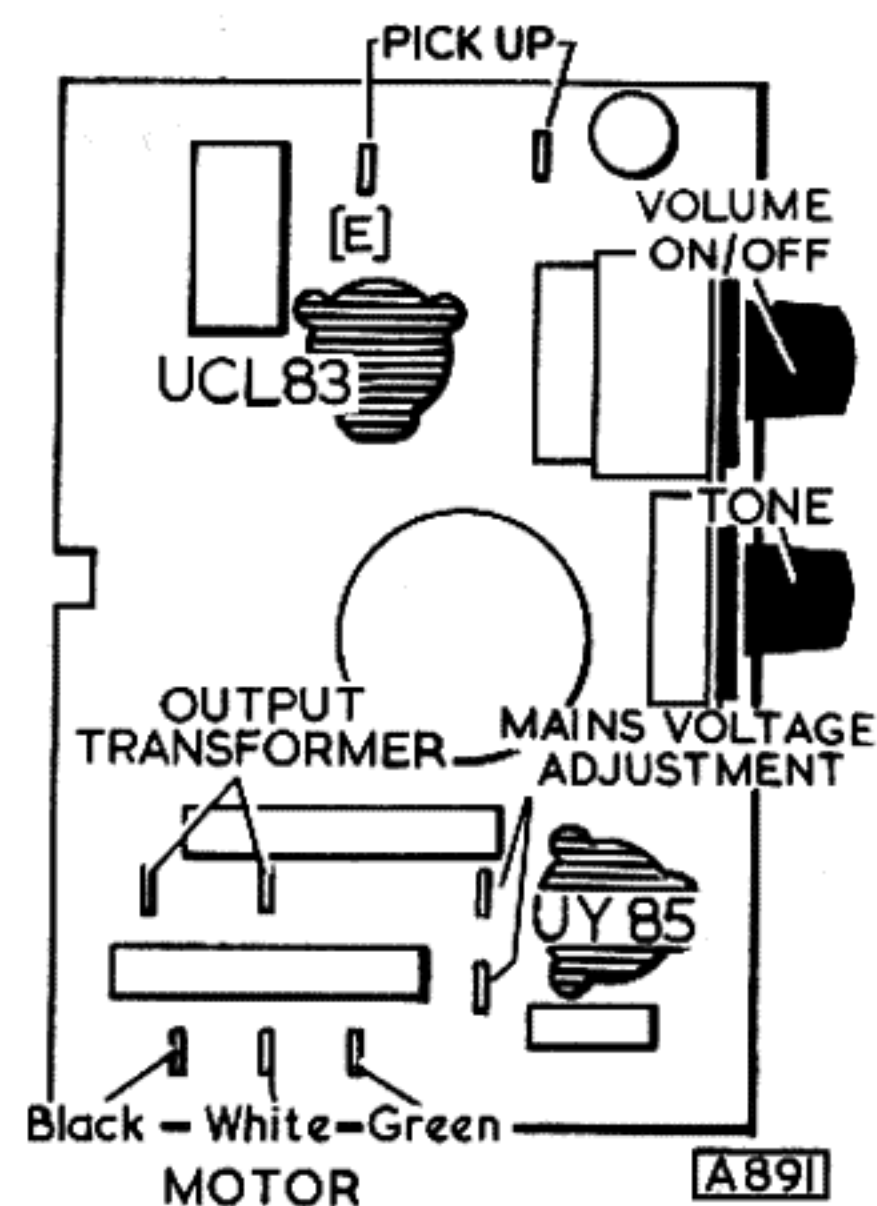

Fig. 3. Pin socket connections to printed circuit panel.

## MECHANICAL SPARES

DESCRIPTION	PART No.
Cabinet .....	V17904
Cabinet partition .....	Y17919
Control escutcheon .....	X17915
Mains voltage selector .....	Z17916
Pin socket lead connector .....	Y21558
Valve holder .....	Z13630