

www.radio-workshop.co.uk



Model AT6 MkIIA

Instruction Booklet

page 2	introduction
page 3	operating instructions
page 7	maintenance
page 8	service adjustments
page 10	installation
page 12	wiring
page 13	fitting cartridge
page 14	service and spares

introduction

The Garrard A.T.6 Mk. IIA is a high quality record changer which provides the facility for manual play if desired.

Its features include a fully counterbalanced tubular pickup arm equipped with a bias compensator, an interchangeable plug-in pickup head, a large-diameter turntable and the famous Laboratory Series motor. A muting switch short circuits the pickup during the record changing cycle.

The A.T.6 Mk. IIA will play automatically up to 8 records of 7", 10" and 12" diameter at the same speed and stylus setting, with the records mixed in any order. A short manual spindle is provided for use when records are to be played singly, as on a single record player. Large centre hole 7"-45 r.p.m. records may be played automatically using spindle type L.R.S.10, or manually using the 45 r.p.m. adaptor, both these items being optional extras.

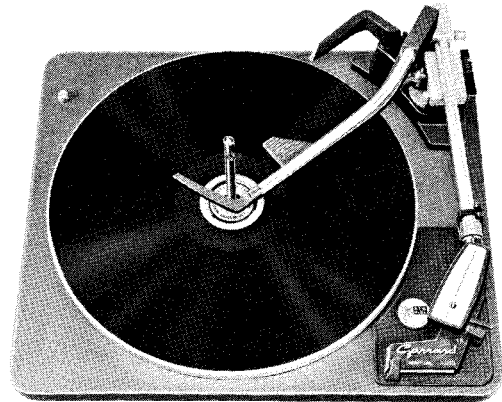

Automatic Play

1. Check that correct stylus is in position and speed control set to required speed.
2. Free pickup arm on rest by releasing safety catch.
3. Place records horizontally on record spindle step and swing overarm fully inwards.
4. Switch on by moving control to AUTO.

After playing all records, the pickup arm will return to its rest and the unit will switch off.

To avoid stylus damage, do not switch to AUTO until records are loaded on the record spindle.

To Unload

1. Lift overarm and swing to right.
2. Lift records clear of spindle, even if replaying the same records.

Manual Play

1. Check that correct stylus is in position and speed control set to required speed.
2. Free pickup arm on rest by releasing safety catch.
3. Place record on turntable and swing overarm fully inwards.
4. Switch on by moving control to MANUAL, then place the pickup on the record.

After playing the record, the pickup arm will return to its rest and the unit will switch off.

Diagram 1

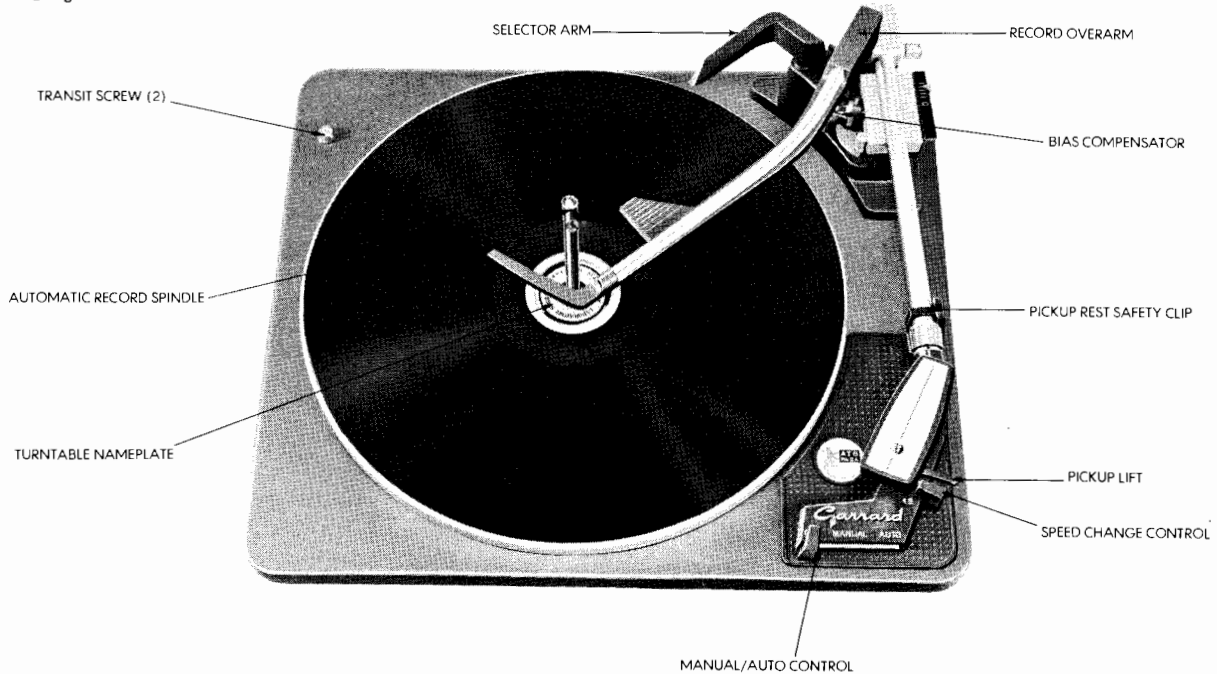

Reject

A record being played may be rejected by moving the control to AUTO.

Stop

Move control to OFF and the motor will stop with pickup remaining on record.

Restart by moving control to MANUAL and same record will continue playing. When refitting the automatic record spindle, rotate it until its location is felt, then press firmly downwards to secure the record spindle in the turntable clip.

Note:

To obtain best results, store and clean records as recommended by the record manufacturers. Do not leave records on the unit when not in use. Keep the stylus free from accumulated dust and replace when worn.

MAINTENANCE

ADJUSTMENTS

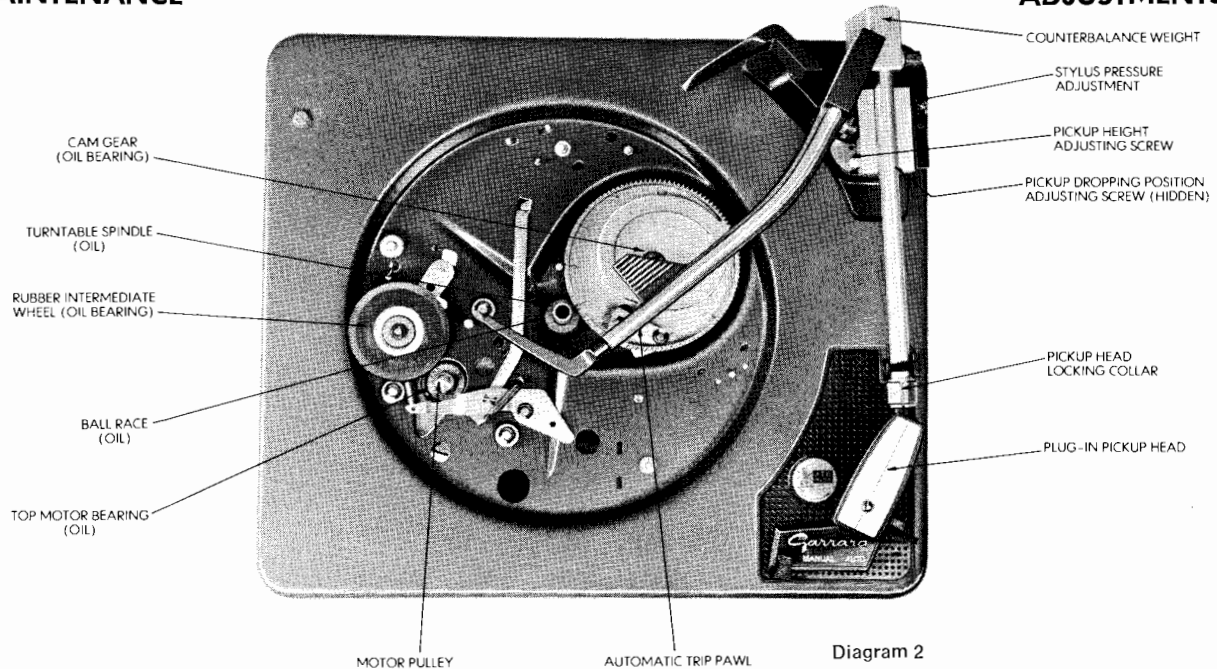

Diagram 2

LIGHTLY OIL ALL PIVOT POINTS

Caution:

Switch off power supply and protect pickup stylus before carrying out any maintenance.

Lubrication of the motor, turntable spindle and intermediate wheel bearings is rarely needed as they are of the oil-retaining type. When the need for oil is apparent, hold the intermediate wheel away from contact with the motor pulley and lubricate the top motor bearing with a fine grade of machine oil. Also lubricate the intermediate wheel and turntable spindle bearings. Other oiling points are shown on Diagram 2. Include lever pivot points if stiffness in the mechanism becomes noticeable. When carrying out maintenance, check that the overarm when swung fully inwards, drops freely in its location. If it does not, clean and oil its spindle.

Remove any excess oil, particularly from the motor pulley, rubber intermediate wheel and inside turntable rim by wiping with a clean cloth.

To remove the turntable pull out the record spindle and prise out the centre nameplate using a screwdriver or pen-knife, taking care not to buckle the nameplate. Now remove the turntable retaining clip (Diagram 3) and lift off the turntable with equal pressure on diametrically opposite sides.

To replace the turntable check that the gap in the teeth of the cam gear is adjacent to the turntable spindle, and that the automatic trip pawl, Diagram 2, is pushed away from the turntable spindle. The turntable will now slide on easily. Assemble the retaining clip in the groove of the turntable spindle with the record spindle removed, as in Diagram 3.

- TO FIT TURNTABLE CLIP
1. ENGAGE CLIP IN TURNTABLE SPINDLE SLOT WITH HOLE IN CLIP AT REAR
 2. PRESS CLIP DOWN HERE TO SPRING OVER CHAMFER ON TURNTABLE SPINDLE

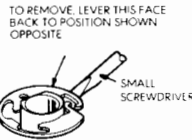
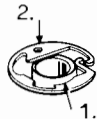

Diagram 3

Protect the stylus and switch off the power supply before making any adjustment. If necessary move the control to AUTO and rotate the turntable clockwise by hand to actuate the mechanism.

Speed

The A.T.6 Mk. IIA is designed to give the required turntable speed within close tolerances. If the turntable runs excessively fast or slow, the motor pulley, Diagram 2, may not be correct for the frequency of the power supply. Check the motor pulley colour finish: Nickel for 50 and Brass for 60 cycles. Fit a replacement pulley if necessary. To reach the motor pulley, remove the turntable as described on page 7 under 'Maintenance'. Should the speed vary during playing, examine the motor pulley, rubber intermediate wheel and inside of turntable rim for traces of oil. Wipe them thoroughly with a clean cloth.

Check that the two small screws holding the motor pulley on the motor shaft are equally tight. See that the rubber intermediate wheel runs in the centre of the appropriate pulley step and is not rubbing the side of the adjacent step. If necessary, adjust the pulley position or the intermediate wheel height setting blade. This blue spring steel blade is found beneath the unit plate and adjusts the height of the spindle on which the rubber intermediate wheel is mounted.

Pickup Stylus Pressure

To set the stylus pressure, loosen the knurled screw holding the pointer on the stylus pressure scale shown on Diagram 4, and slide the pointer to the zero mark on the scale. Now loosen the screw holding the counterbalance weight to the rear of the pickup arm. With the pickup arm off its rest, slide the weight along the arm until the point of balance with the pickup head is obtained—the pickup arm will then be horizontal. Tighten the counterbalance weight fixing screw. To set the required stylus pressure slide the pointer along the scale, graduated in approximately 1 gram divisions, then tighten the pointer locking screw. The stylus pressure should be set to the pickup cartridge manufacturer's recommendation.

Pickup Dropping Position

The pickup dropping position is factory-set for optimum accuracy but a minor adjustment may be required if a new cartridge is fitted. This can be carried out by turning the horizontal screw set beneath the pickup arm a small amount clockwise to move the dropping position inwards or counterclockwise to move it outwards. This screw is shown on Diagram 4.

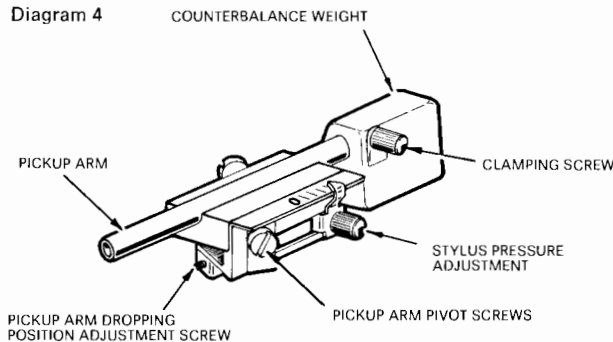

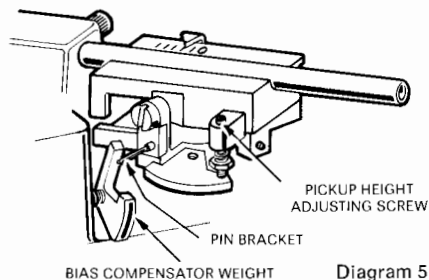

Diagram 5

Pickup Height

The height that the pickup lifts off the record can be adjusted by turning the top screw at the left hand side of the pickup arm pivot bracket (see Diagram 5). The height should normally be set so that the stylus point is $\frac{3}{8}$ " above one record on the turntable as the pickup arm is returning to its rest. When a cartridge of exceptional depth is fitted, the figure given may be less and it may not be possible to play as many records in automatic sequence.

Pickup Tracking

Should there be a tendency for the pickup to track incorrectly, check that the correct stylus is used for the type of record being played, and is free of accumulated dust. Check that the stylus pressure is that recommended by the pickup cartridge manufacturer. The bias compensator counteracts the inherent force of the pickup towards the turntable centre, therefore make certain that the bias compensator pivots freely. See that the leads from the rear of the pickup arm are free and clear of the side of the slot where they pass through the unit plate.

To remove and replace the Pickup Head

To remove the pickup head, unscrew its locking collar (Diagram 2); gently pull the head from the arm. To replace the head, locate the pin on the pickup head in the slot in the pickup arm and slide the head in. Then bring the locking collar forward and screw it up until tight.

To engage the Bias Compensator

The unit may be supplied with the bias compensator disengaged. If this is the case then the pin bracket should be swung to the position shown in Diagram 5 so that its pin will carry the compensator weight while the pickup arm is on the record.

The instructions on pages 10 to 13 do not apply if your A.T.6 Mk. IIA is already fitted to a cabinet.

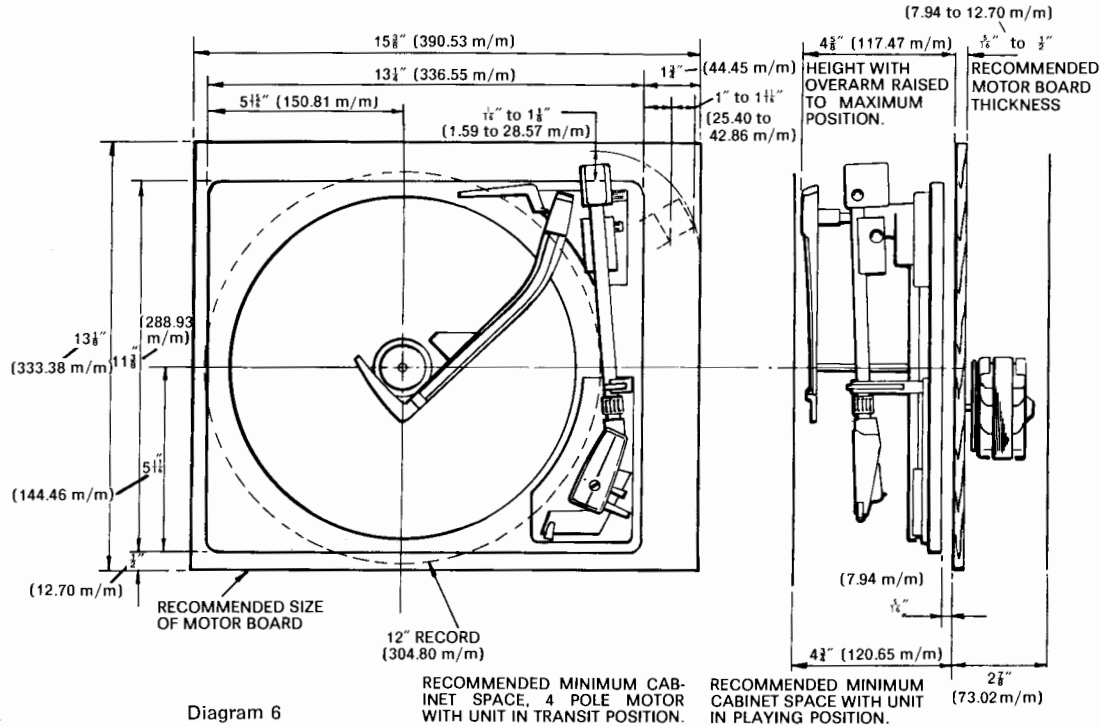

Diagram 6

RECOMMENDED MINIMUM CABINET SPACE, 4-POLE MOTOR WITH UNIT IN TRANSIT POSITION.

RECOMMENDED MINIMUM CABINET SPACE WITH UNIT IN PLAYING POSITION.

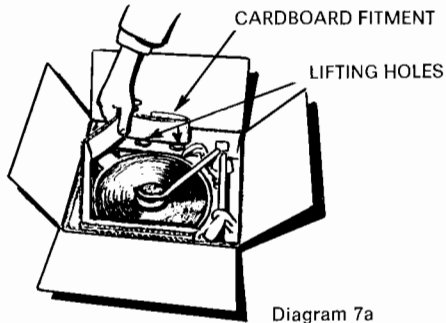

Diagram 7a

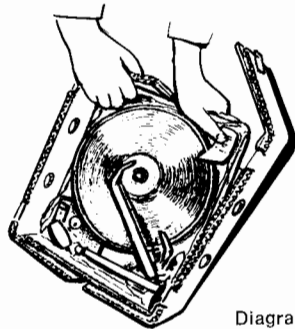

Diagram 7b

Unpacking

WARNING: Do not lift unit by pickup arm or overarm.

Referring to Diagrams 7a and 7b, proceed in the following way:

- 1 Remove cardboard fitment from top of unit and withdraw liner containing unit, using lifting holes in side of liner.
- 2 Remove accessories from liner sides.
- 3 Hold one side of liner clear to get a firm grip on unit.
- 4 Take unit from liner, then hold it on edge to remove pickup ties, rubber bands and cardboard wedges from turntable and motor.
- 5 Remove plastic band protecting unit plate.

Fitting

To fit the unit to a cabinet proceed as follows.

- 1 Drill and cut the motor board to the template supplied. Do not moisten this template as it may distort but fix it with adhesive tape. Recommended motor board thickness is $\frac{1}{8}$ " to $\frac{1}{4}$ ". If thicker, it will be necessary to recess the transit screw holes from the underside $1\frac{1}{2}$ " diameter to clear the transit screw clips.
- 2 Fit the counterbalance weight to the back of the pickup arm with its clamping screw forward, as in Diagram 1.
- 3 Attach the power supply, earth and audio leads as instructed under 'Wiring'.
- 4 Check that the transit screws are right down, see Diagram 1; then, with their locking clips vertical, place the unit on the motor board so that the screws pass through it. Make sure that any foam damping pads are inside the spring mountings and that these springs engage their recesses in the motor board.
- 5 When the unit is in place turn the transit screw locking clips horizontally.
- 6 Insert the record spindle in the turntable spindle and rotate it until location is felt, then press firmly to secure it in the turntable clip shown in Diagram 3.
- 7 Engage the bias compensator and set stylus pressure, as instructed on pages 8 and 9.

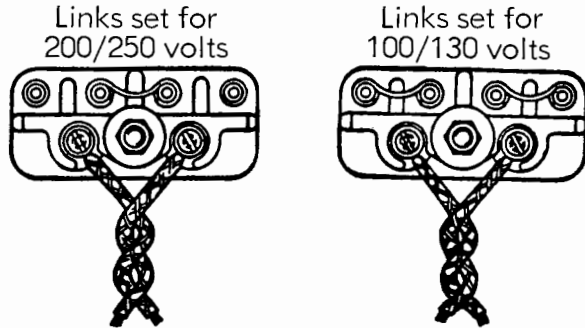

Diagram 8

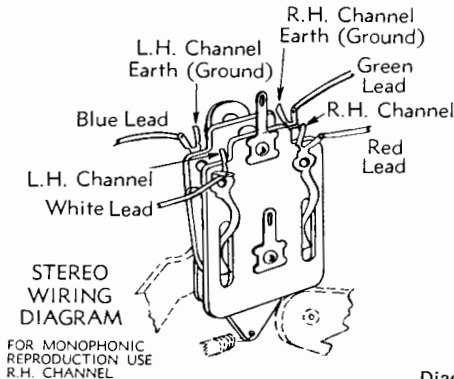

Diagram 9

The A.T.6 Mk. IIA has a dual-voltage motor for both 100/130 and 200/250 volts A.C. operation according to the setting of two wire links in its combined voltage changeover and power supply block which is shown on Diagram 8. It can be used with supplies of 50 or 60 cycles. A separate pulley is required for each frequency, these being interchangeable and easily distinguished. The 50 c/s pulley is nickel plated and the 60 c/s pulley is brass.

Power Supply Leads

Attach a flexible lead to the terminals in the power supply connecting block adjacent to the motor.

If a power supply socket is fitted, use a lead with a suitable plug.

If a power supply lead is fitted or the motor leads are extended, connect direct to the electric supply.

Earth (Ground) Lead

Attach a lead between a good earthing point and the tag adjacent to the power supply connecting block.

Amplifier (Audio) Leads

If the unit is to be connected to an amplifier whose circuit is not isolated from the power supply by means of a transformer it is essential to make sure that isolating components, condensers or transformer, are incorporated in its pickup input circuit. If in doubt consult your dealer. Connect a screened lead from the amplifier pickup input plug to the pickup circuit muting switch tags in accordance with Diagram 9. Each lead should be as short as possible.

When using a stereophonic cartridge with a monophonic amplifier, parallel the two channels.

If audio leads are already fitted, the brown lead carries the right hand channel and the grey lead carries the left hand channel. When a monophonic pickup cartridge is fitted use the brown lead. The inner conductor is 'live' and the screen 'earthy' in each case.

Note.—Make sure all leads are free so that they do not restrict the movement of the unit on its springs.

Fitting Pickup Cartridge

A plug-in pickup shell designated M6 or M7 is used on the A.T.6 Mk. IIA. This may be supplied with or without a pickup cartridge. The pickup shell kit, less cartridge, part number 59048, contains a set of fixing accessories comprising:

Alternative mounting plates

Two 6BA x $\frac{3}{16}$ " screws

One 6BA x $\frac{1}{8}$ " screw

These parts allow most types of cartridge to be fitted without difficulty by fixing the cartridge to the mounting plate which has the most suitable length of stand-off and securing the assembly to the pickup shell with the $\frac{1}{8}$ " screw. Cartridges having a single fixing hole may be fitted directly to the pickup shell using the $\frac{1}{8}$ " screw.

The M6 is deeper than the M7 and preferable if a large cartridge is to be fitted, but is otherwise similar.

Connect the colour coded leads in the pickup shell to the connection tags for the cartridge. Do not solder leads directly to the cartridge. Lead connections should be made as follows:

Red to Right Channel Signal

Green to Right Channel (Earthy)

White to Left Channel Signal

Blue to Left Channel (Earthy)

Information on its connections is usually supplied with the cartridge. For cartridges having three connections, use the green lead as the common connection or join the green and blue leads together and use these as the common connection. For monophonic cartridges use the red and green leads. Insulate and tuck away any leads not required.

Diagram 9

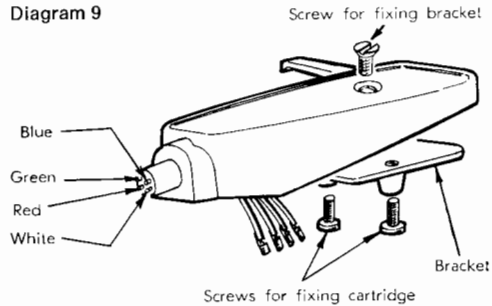

This booklet provides all the information likely to be needed during the long, trouble-free life of your Garrard unit, but if you require further assistance please contact your dealer, or in the case of difficulty our Service and Spares Department, or Agent in overseas countries.

Spare Parts

When ordering spares please quote A.T.6 Mk. IIA, the code number on our inspection label, and part number; with colour, voltage and frequency range when applicable.

If a replacement Garrard cartridge is required please quote its model number, and be sure to use only genuine Garrard diamond or sapphire tipped styli for guaranteed results. Fitting instructions are printed on the packets in which our own styli are supplied.

spare parts list

Description	Part No.
Automatic Record Spindle	70932
Manual Record Spindle	58954
Large Record Spindle—L.R.S.10	70960
Turntable	71692
Turntable Mat	57422
Pickup Head Shell—M6	58891
Pickup Head Shell—M7	70870
Pickup Arm Counterbalance Weight with Screw	59080
Motor Pulley 50 c/s	58646
Motor Pulley 60 c/s	58650
Intermediate Wheel	58220

Service and Spare Part enquiries to:
Garrard Engineering Limited,
Service and Spares Department,
50-54 Radnor Street,
SWINDON,
Wilts.

Telephone Number: **SWINDON 22606**

www.radio-workshop.co.uk

