

# SERVICE ELECTRICAL and RADIO CHARTS

TRADING

GARRARD AUTO MIXED-  
RECORD CHANGER  
FERGUSON 203U  
McMICHAEL 483

www.radio-workshop.co.uk

## GARRARD AUTO MIXED-RECORD CHANGER RC 60

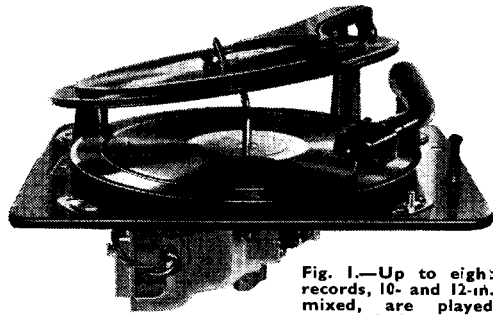

Fig. 1.—Up to eight records, 10- and 12-in. mixed, are played automatically by the RC60

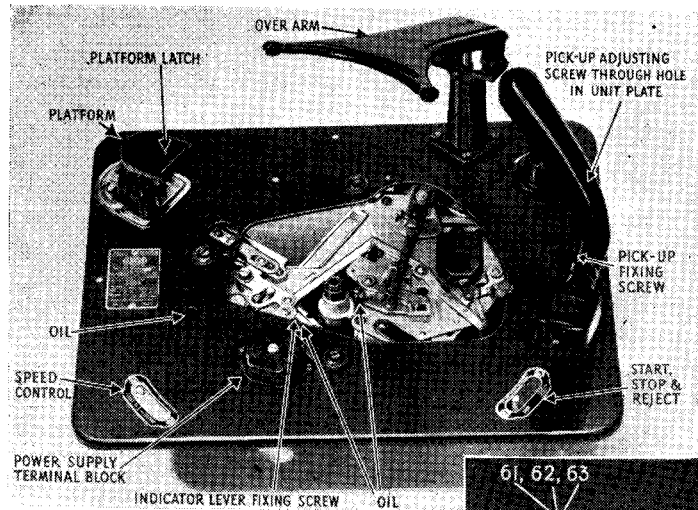

Fig. 2.—General view of the changer identifying main features, including the platform with pawl and the over-arm, but with the record spindle removed

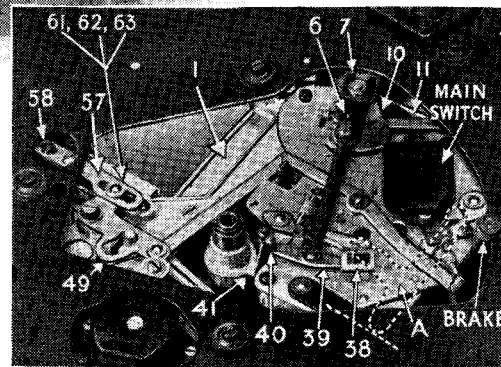

Fig. 3.—Close-up of mechanism with turntable removed. The numbered parts are referred to in the text, where both the principle of operation and maintenance adjustments are explained. 152 is pawl inside platform

The Garrard RC60 Record Changer will play any number of records up to eight, with 10- and 12-inch mixed in any order. The changer is supplied in two types—Model RC60/D16 for operation on 40-60 c/s 100-130 and 200-250 volts AC, and Model RC60/U16 for 100-130 and 200-250 volts DC and AC 25-60 c/s. Fitted with plug-in Garrard magnetic pick-up which is interchangeable with crystal type without alteration. Made by The Garrard Engineering and Manufacturing Co., Ltd., Swindon.

### DESCRIPTION

THE changer is a self-contained unit (Fig. 1) fitted on a 15 by 11½-in. plate with either AC induction (D16) or universal (U16) type motor, 10-in. turntable and magnetic or crystal pick-up. The motor, in addition to rotating the turntable, operates the changing mechanism.

The unit is assembled in a die-cast aluminium sub-chassis to which is screwed the brown enamelled top plate. The pickup, record platform and over-arm (see Fig. 2) are also finished in brown enamel. The record spindle, control lever and escutcheons are chromium finished.

### PRINCIPLE

Referring to diagrams 1, 2, 3, 4 and 5, with records loaded on the record spindle and the over-arm lowered on to the records, and a needle in the pick-up, the right-hand control knob is pushed over to the "Start" position.

This, via lever A (Fig. 3), closes the main switch, moves brake away from the turntable rim and pivots the clutch-release lever 38, with associated lever underneath the auto-stop base plate, and also the knock-off catch lever 139 (Fig. 4) out of the way of clutch lever 133, allowing spring to pull the catch on the clutch lever into mesh with the teeth on clutch.

The motor then revolves the main cam shaft on which are mounted the cams controlling the various functions of the mechanism.

The platform moves back so that the tip of pawl 152 (Fig. 5), which performs the dual function of sensing the size of the record and pushing it off the platform, shall clear the edge of the record. The height of the tip is such that when the record to be played is a 10-in. and the next record is a 12-in., the 12-in. record does not affect the pawl.

The cam, via lever B (Fig. 5) pulls the platform forward against the tension of a spring, but does not push it back. The spring pulls it back.

When the cam releases the platform, and the spring pulls it back, unless the tip of the pawl is depressed by a 12-in. record, the rear of the pawl engages against the platform stop. The platform is held in the 10-in. position, and the track follower connected to lever B is guided into the 10-in. track on the cam.

When tip of pawl is depressed by a 12-in. record, the rear of the pawl passes over platform stop and allows the spring to pull the platform right back into the 12-in. position and the cam track follower is fed into the 12-in. track on the cam.

Connected to the platform is the system of levers 57, 49, 1 and 74, and when the platform selects either the 10-or 12-in. position it also, via these levers, positions the pin on the end of selector lever 74, so it engages the 10-or 12-in. steps on pick-up arm lever 76, thereby bringing the needle to the correct position for the size of the record.

Action of pick-up arm.—The movement of the pick-up arm during the changing cycle is controlled by the cams 94 and 96 (Fig. 4).

When the unit is switched on, a node on cam 94 pivots the lifting lever unit 170 (Fig. 5) which depresses the friction disc unit 172 and lifts the pick-up arm clear of pick-up rest. Immediately the arm is clear of the rest, a valley in cam 96 releases the pick-up cam lever unit 84, which in turn allows spring 85 to pull in the pick-up arm until eccentric pin 180 engages against lever 76, which is set for 10-or 12-in., as outlined above.

Immediately lever 84 has left the pick-up arm pivot, and eccentric pin 180 and lever 76 is holding the pick-up in the correct position, a valley in cam 94 allows lever 170 to lower the pick-up on to the record and a deep valley in each cam allows all the levers to move clear of the pick-up arm unit, leaving it free to traverse the record.

Auto-trip mechanism.—When the pick-up has played approximately two-thirds of the record the lug on the pick-up arm lever engages link 11 (Fig. 3), and through this link moves friction plate 10.

The operating lever 7 is moved by the friction plate 10 through a very delicate friction drive between a felt pad underneath the operating lever and the polished surface of the friction plate.

As the operating lever moves towards the centre the rubber bush 40 comes slowly into the orbit of the revolving striker 41, which gently brushes the surface of the bush, pushing it back out of the way.

This process continues as long as the needle on the record is in the playing groove. The friction drive relaxes to allow these two contrary movements to take place.

When the needle leaves the playing grooves and enters the run-off groove on the record, the extra motion imparted to the operating lever 7 moves the tip of the trip lever 39 into the orbit of the striker, which now, instead of brushing back the rubber bush, strikes the tip of the trip lever, causing it to rise slightly to free the friction drive and to pivot on its fulcrum and operate the clutch release lever 38 recommencing the changing cycle.

As mentioned under "Action of pick-up arm," the track follower on lever 170 lies in a deep valley during the playing period in order to leave the pick-up free. One side of this valley is very steep, so that immediately the cam recommences to revolve the track follower has to move sharply out of the valley. This lifts the pick-up almost vertically off the record, and soon after cam 96 brings the pick-up neck to the rest ready for the next record to drop.

Action of platform.—In addition to the action described earlier, the platform has a tilting motion controlled by levers 167, 165 and 161, which lowers it to pass underneath the magazine of records.

Overarm.—The overarm (Fig. 2) has three functions:—

(A) The rubber pad nearest to the platform rests on the magazine of records to keep them in contact with the platform.

Continued on next page

## GARRARD RC 60—Contd.

(B) The pad nearest the pick-up arm, which normally is clear of the record by approximately  $\frac{1}{8}$  in., comes into action when the record dropped is a 12-in. and the remaining record or records are all 10-in. When the 12-in. record falls the platform is back in the 12-in. position, and as the 10-in. records remain suspended on the record spindle the pad prevents them tipping up into the path of the incoming platform and fouling it.

(C) When the last record has dropped on the turntable the platform falls and depresses the rod situated in front of the platform support. This rod releases the auto switch mechanism which operates at the end of the record.

**Overthrow mechanism.**—When the clutch lever is engaged by knock-off catch lever 139 (Fig. 4) at the end of a batch of records, or by the lip on the underside of clutch release lever 38 at the end of a changing cycle during a programme, it is prevented from continuing to revolve with the cam mechanism to which it is attached. Pivoting slightly on its fulcrum, it disengages from the clutch attached to the motor, thereby leaving the motor free to play the record.

When the clutch lever is released from the clutch the residual motion in the cam mechanism is not sufficient to move it quite clear, and it would make intermittent contact with the teeth on the clutch causing a clicking sound during the programme. To prevent this, the overthrow lever 102 is fitted. This is controlled by a relatively powerful spring 169 and operates on a pin on the swing cam 96.

As the cam revolves the pin rides up the side of the lever, pivoting it and putting a tension on the spring. At the moment the clutch lever is disengaged from the clutch, the pin on the swing cam reaches the end of the lever and the tension stored in the spring makes the inclined end of the lever give the pin a kick round. The extra movement thus imparted to the cam mechanism ensures that the clutch lever is quite clear of the clutch.

### ADJUSTMENTS

If the record changer has been stopped for any reason, with the pick-up arm not on the rest, the arm should not be interfered with, but the motor restarted and the arm allowed to return to the rest.

**Pick-up dropping position.**—The pick-up has been finely adjusted so that the needle comes on to 10-in. records in a  $9\frac{3}{8}$ -in. diameter circle and 12-in. records in a  $11\frac{1}{8}$ -in. diameter circle.

There may be a few records where the track starts further away from the centre, and in these exceptional cases the needle may alight on the record a few grooves from the start of the record. If the pick-up dropping position were set for these exceptional records it would not be suitable for average records.

Should the dropping position of the pick-up require adjustment, the pick-up adjusting screw, which rotates the eccentric pin (180, Fig. 5) should be turned with the changer in its start position; that is, with the pick-up arm on its rest. A quarter of a turn in either direction will give the maximum adjustment. After adjustment, switch on and check the dropping position.

Occasionally the pick-up will select the 12-in. position irrespective of whether a 10- or 12-in. record is to be played. This fault is usually due to the

pick-up arm timing either being set a shade too fine or having slipped.

To correct the timing operate the changer until the platform is in its most forward position, then stop the motor. Slacken screws 58 (Fig. 3), bring lever 49 forward until the elongated slot is hard on the stop formed on the base casting.

Hold lever in this position and bring lever 57 forward hard on the collar assembly 61, 62 and 63, then ease it back approximately  $1/32$  in. and retighten screws 58.

**Pick-up height.**—The height to which the pick-up rises is controlled by the friction disc unit 172 (Fig. 5), which may be screwed up or down as necessary after releasing set screw.

The height the pick-up rises should be such that a long needle just clears the surface when returning to the rest after playing the eighth record.

If the pick-up does not fall low enough to play the first record on the turntable, stop collar 177 should be screwed down after releasing set screw.

After carrying out any of these adjustments always remember to retighten the set screws, otherwise the settings will not remain constant.

**Caution.**—When making adjustments to the pick-up arm, it should never on any account be forced into position. If the turntable is turned by hand it should not be turned backwards. If the pick-up does not run into the record grooves after alighting on the record edge, check the level of the unit by placing a spirit level on a record on the turntable. Also make sure that the flexible pick-up lead is not twisted or restricting movement of pick-up arm and that levers operating pick-up arm are free from obstruction or are not jammed.

**Auto-trip mechanism.**—Satisfactory operation of the changer depends upon the operation of the auto trip. Occasional adjustment of the auto-trip friction spring may be necessary.

If, at the end of a record, the auto trip does not operate—that is, the pick-up remains at the end of a record—first see that the record has a run-off groove in its centre, as only records with run-off grooves can be played automatically. If the record is in order, increase the tension of the friction spring by turning the friction adjusting screw 6 (Fig. 3) in an anti-clockwise direction; about half a turn is all that should be necessary. This screw is accessible on removing the turntable.

When the changer operates before the end of a record or a bumping or tapping noise is audible, first examine the trip lever rubber 40 (Fig. 3) and, if worn, give it a half turn to present a new surface to the striker. If badly worn, renew. If trip lever rubber is in good condition, then reduce the tension of the friction spring (half a turn in a clockwise direction).

**Certain records not operating changing mechanism.**—The radius of operation for the auto-trip mechanism in the early models was set to operate on all recordings in the last 10 years or so. Unfortunately, some reissues of 1932 recordings have been made which require a larger radius of operation.

To overcome this difficulty a clip has been fitted to the auto-trip operation lever to increase the radius of operation. The clip and instructions for fixing are available from the factory at Swindon.

**Auto stop.**—The changer should switch off the motor after the last record has been played. If it does not do so, and repeats the record continuously, or conversely, stops after every record and does not automatically change, a knowledge of the auto-stop mechanism is necessary to correct it.



Groping and rule of thumb methods are out of date—the times call for accuracy and speed in servicing.

Have the facts given to you simply with this complete instrument—for which you will find a use at every turn of your day-to-day work. The Hunt Capacitance and Resistance Analyser is a high grade precision instrument developed by specialists in Capacitor design and manufacture—hence it is practical in conception and complete in application, a master instrument in every respect.

**HUNTS**  
**CAPACITORS**  
TRADE MARK

**CAPACITANCE &  
RESISTANCE  
ANALYSER**

MEASURES capacity, power factor, resistance, insulation resistance. DETECTS defective capacitors. TESTS continuity, etc.

One dial reading without charts or graphs. Complete—no headphones, external meters or similar accessories required. Robust and extremely portable.

Rating: 210-250 v. A.C. 50 cycles.  
Dimensions:  $6\frac{1}{2}$ " x  $9\frac{1}{2}$ " x 5"

List Price £18.18.0

A. J. HUNT LTD · LONDON · S.W.18 · ESTABLISHED 1901

Fig. 6 shows the layout of the levers concerned. An  $\frac{1}{4}$ -in. diameter rod A, in front of the overarm support, is pressed down when the overarm is lowered. The rod rests on lip B of the lever C which is pivoted on its fulcrum D when the overarm presses down the rod. The composite lever E is operated by the peg F on the cam G.

The cam makes one revolution for a complete changing cycle. The diagram shows the position of the levers when the overarm is raised by records on the platform to be played. When the peg F passes the tip of the lever E the two parts of the lever, held solid by the spring K, attempt to pivot on the fulcrum L, but the tip H of lever C prevents the part J from moving, so the spring K relaxes and allows E to pivot separately on fulcrum M.

When the last record has fallen, the weight of the overarm pressing down A pivots C and lifts the tip H clear of J. J, now being free to move with E, pivots on L the next time E is operated by the peg F; the top of J operates the auxiliary clutch and the motor switch, stopping the changer at the completion of last record.

It will be seen that if the changer fails to stop, the lip H is not being lifted clear of the lever J, and to correct this the tip B should be bent up slightly to give increased movement to lever C when depressed by A.

If the changer stops after every record instead of automatically changing and playing the next record, either the lever C is held up, leaving J clear to move, or the gap between H and J is too large again, allowing J just sufficient movement to switch off the motor.

If C is held up, it may be necessary to bend down the tip B, and if the gap is too large the tip H can be bent nearer to J.

**Platform adjustment.** The record platform (150, Fig. 5) is set to accommodate records of average dimensions. Occasionally records may be found outside the normal limits; if necessary, the platform may be adjusted to take them.

To control the platform movement are two adjustable links, each fitted with two screws. One link (165, Fig. 5), with its pivot at the bottom of the platform lever, controls the platform lift, whilst the other (B) controls the distance the platform moves inward.

It is this latter link which may be adjusted to accept records differing from the normal in diameter. To do this, loosen the screw further away from the platform and remove the other screw. Now refit this screw in an adjacent hole according to the adjustment required. Moving the screw to a hole nearer the platform lengthens the link and increases the inward movement of the platform. By moving the screw in an opposite direction the link is shortened and the outward movement of the platform increased.

The permissible adjustment is one hole on either side of existing position of the screw.

**Pick-up returning to rest after playing record, but next record does not drop. Motor continues to revolve.** If the top of the lever J (Fig. 6) is inspected, it will be noted that there are two levers operated by it. One on top of the auto-stop base plate controls the motor switch, and one underneath the plate controls the auxiliary clutch. The one which controls the clutch is slightly in advance of the lever which controls the switch, and is therefore operated earlier by the lever J.

The trouble in this case is the gap between H and J is just big enough to allow sufficient movement in J to operate the clutch lever but not the

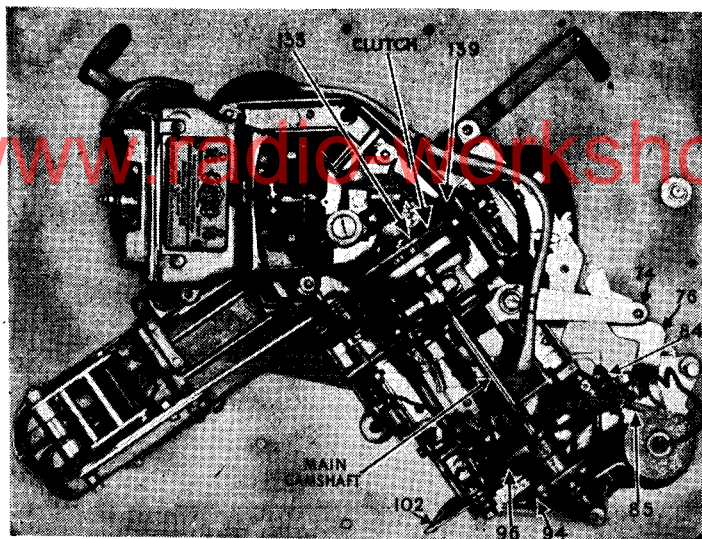

switch lever, and the remedy is to bend the lip H closer to J to decrease the gap.

**Pick-up arm not free to travel across record.** This is usually due to the lever 76 (Fig. 4) being bent and rubbing against the frame if it is bent up or lever 74 if it has been bent down. Lever 76 should be clear of all obstructions, only touching the stud on the end of lever 74 when the selector mechanism is checking the size of the record.

**Pick-up.** Garrard magnetic types of pick-up are interchangeable with the crystal without alteration to the pick-up arm, provided the pick-up is fitted in a Garrard head.

The pick-up heads are of the plug-in type with plug and socket connections at the back of the head.

**To remove pick-up head.** Unscrew the pick-up fixing screw, withdraw the pick-up, easing the pick-up lead under the arm, and remove the two plug connections from back of pick-up.

If reproduction ceases, or becomes distorted when fitted with a "Garrard" standard magnetic pick-up, first make sure that the amplifier is in order. Should this be found satisfactory, a slight adjustment to the pick-up may be necessary or the damping rubber may need renewing.

To examine pick-up proceed as follows: Remove the pick-up cover, and by viewing the front of the pick-up, examine armature to see that it is in the centre of the gap between the pole pieces.

If it is touching one of the pole pieces it must be re-centred. To do this, loosen the two screws holding the adjusting plate, slide the latter until the armature is in the centre, then tighten the screws.

If the armature will not retain its centre position, it will be necessary to renew the damping rubber. This can be done by removing the adjusting plate, replacing the rubber and re-assembling the plate. Adjust the plate until armature is centred before tightening the screws.

The top damping rubber tends to perish in time. It should, therefore, be replaced whenever it appears that the needle stiffness has increased, otherwise excessive record wear may occur.

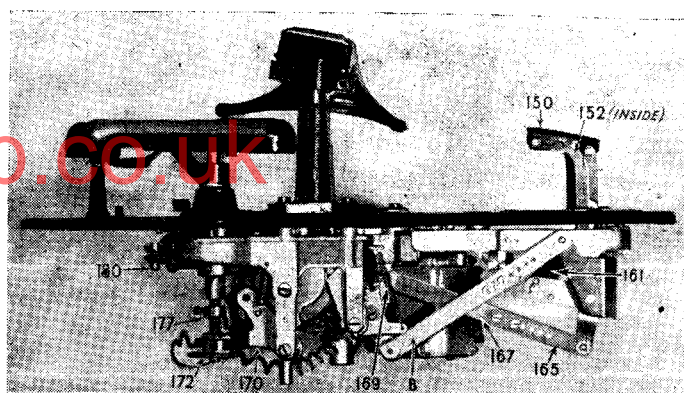

Fig. 5 (above) — side view, which includes the levers associated with the platform

Fig. 4 (left) — under-side view

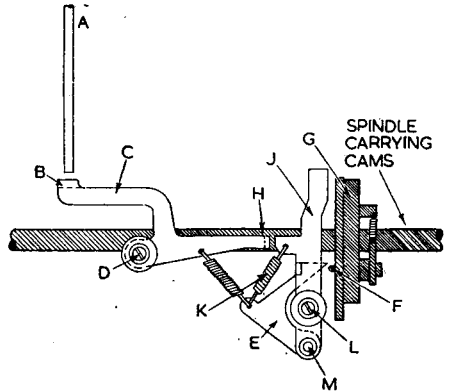

Fig. 6.—Switch and clutch mechanism controlled by the overarm

Distortion can be caused by dirt or foreign matter in the gap between the pole pieces. To remedy, remove the adjusting plate and damping rubber and clean gap.

The pick-up coil winding can be checked for continuity with an ohmmeter.

If a crystal or high-fidelity pick-up is suspect, the pick-up head should be returned for examination. A continuity test cannot be carried out on crystal pick-ups with an ohmmeter. Crystal cartridges and high-fidelity pick-ups must not be opened or the manufacturers will disclaim responsibility.

### MOTOR MAINTENANCE

If the motor fails to start when the control knob is turned to "start," first check the power supply and ascertain if current is reaching the motor terminals. Next examine the terminal block and see that the leads and screws are tight; also examine the switch contacts, clean and adjust if necessary.

The motor requires occasional lubrication, depending, of course, on how often the changer is used. Lift off turntable and insert a few drops of Garrard or thin lubricating oil in oil holes (Fig. 2).

If a thick oil has been used to lubricate the bearings the motor will appear weak or will not start. The motor will have to be dismantled and all traces of the heavy oil removed. Should motor run hot, check that voltage changeover links are set according to the voltage of the mains supply in use. Wavy reproduction from records is usually due to dry governor pads. These should be lubricated by saturating the felt pads with oil. To cure governor rattle, put a little thick oil on the shaft where the governor sleeve slides.

**RC60/D16.** This is an induction motor designed to work on 40-60 c/s AC mains of 100-130 and 200-250 volts.

To check motor windings insert a meter in either motor lead. The maximum current consumption should not exceed 0.11A on 200-250V, 0.22A on 100-130V or 0.24A on 110V 60 c/s.

If readings in excess of these are obtained, then

motor unit should be returned to manufacturers for examination.

**RC60/U16.** This is a universal motor to work on 100-130V, 200-250V DC and 25-60 c/s AC.

Periodical examination of the carbon brushes should be made. If they are allowed to become dirty or worn, brush noise will occur. The brushes can be cleaned by lightly scraping the contact surface with a penknife. It is essential that the brushes be returned to their original holders and the same way round as previously. New brushes are  $\frac{1}{8}$  inch long under the springs. When worn to  $\frac{3}{8}$  inch they should be replaced.

**To remove motor.** Disconnect switch leads from the switch and remove clips holding the leads. Then remove motor fixing bolts and withdraw motor.

*Note: the numbers on the illustrations can be employed when ordering parts from the Garrard Engineering and Manufacturing Co., but should be cited as "drawing numbers," not part numbers. When other replacements are required, it is advisable to return the damaged parts, making sure they are securely labelled.*