

G.E.C. "TOUCHTUNE" THREE-BAND FIVE

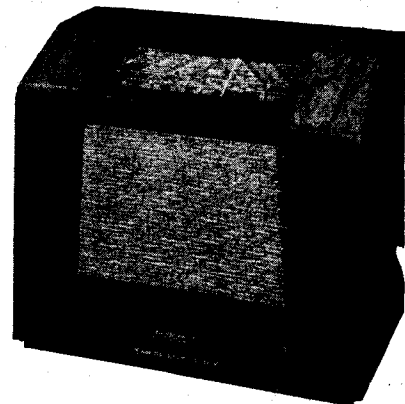

Three band reception and push-button tuning are featured in the G.E.C. 3960 Touchtune Five at £13 2s. 6d.

CIRCUIT.—The aerial coupling is either via a series condenser or direct to a set of H.F. aerial transformers. An aerial input shunt resistance is included for local station reception. The first valve is a triode hexode frequency changer and is A.V.C. controlled. The H.T. feed to the screen and oscillator anodes is via a separate H.T. decoupling circuit to ensure constant operation.

An iron-core I.F. transformer, tuned to 456 kcs., provides the coupling between the frequency changer and the I.F. amplifying valve V2, an H.F. tetrode; V2 is also A.V.C. controlled.

Another I.F. transformer of similar construction feeds the demodulating diode of V3, a double-diode triode. The connection to the demodulating diode load is effected by an H.F. filter circuit, and the rectified potentials are fed to the triode grid via an L.F. coupling condenser and manual volume control.

The other diode of V3, fed by a coupling condenser connected between the diodes, provides a D.C. potential that operates the A.V.C. circuit.

V3 is resistance coupled to V4, an output tetrode. A tone-modifying circuit (R29 and C32) is connected between the

anode of the valve and chassis, and C22 is a fixed-tone modifier.

Mains equipment consists of a mains transformer, a full-wave rectifying valve, four electrolytic smoothing condensers, and a smoothing choke (the speaker field).

Chassis Removal.—The cabinet has a (Continued lower in column.)

WINDINGS (D.C. Resistances)

| L. | Ohms. | Range. | Where Measured. |
|-----------------|----------|--------|-----------------------------|
| 1 | .3 | — | C2 and R2. |
| 2 | .2 | S.W. | Top grid V1 and chassis. |
| 3 | 3 | M.W. | Top grid V1 and R2. |
| 3+4 | 27 | L.W. | Top grid V1 and R2. |
| 5 | .4 | S.W. | R7 and C11. |
| 6 | Below .1 | S.W. | C7 and C10. |
| 6+7+8 | 12 | L.W. | C7 and P2 |
| 9 | 7 | — | Anode V1 and C33. |
| 10 | 7 | — | Top grid V2 and C12. |
| 11 | 4 | — | Anode V2 and C33. |
| 12 | 4 | — | C15 and C16. |
| 13 | 1,200 | — | Outside tags speaker panel. |
| O.T. prim. | 485 | — | Across C22. |
| M.T. prim. | (200v.) | — | Mains plug pins. |
| | 34 | — | |
| Total H.T. sec. | 580 | — | Anode pins V5. |

VALVE READINGS

No signal. Volume maximum. M.W. band. 200 volt A.C. mains.

| Valve. | Type. | Electrode. | Volts. | Ma. |
|--------|-----------------|------------|--------|-----|
| 1 | All Ostram. X65 | Anode .. | 230 | 2.4 |
| | | Screen .. | 77 | 3 |
| | | Osc. anode | 90 | 2.8 |
| 2 | KTW63 | Anode .. | 230 | 0.5 |
| | | Screen .. | 83 | 1.5 |
| 3 | DH63 | Anode .. | 80 | .48 |
| 4 | KT63 | Anode .. | 212 | 30 |
| | | Screen | 230 | 5 |
| 5 | U50 | Heater .. | 315 | — |

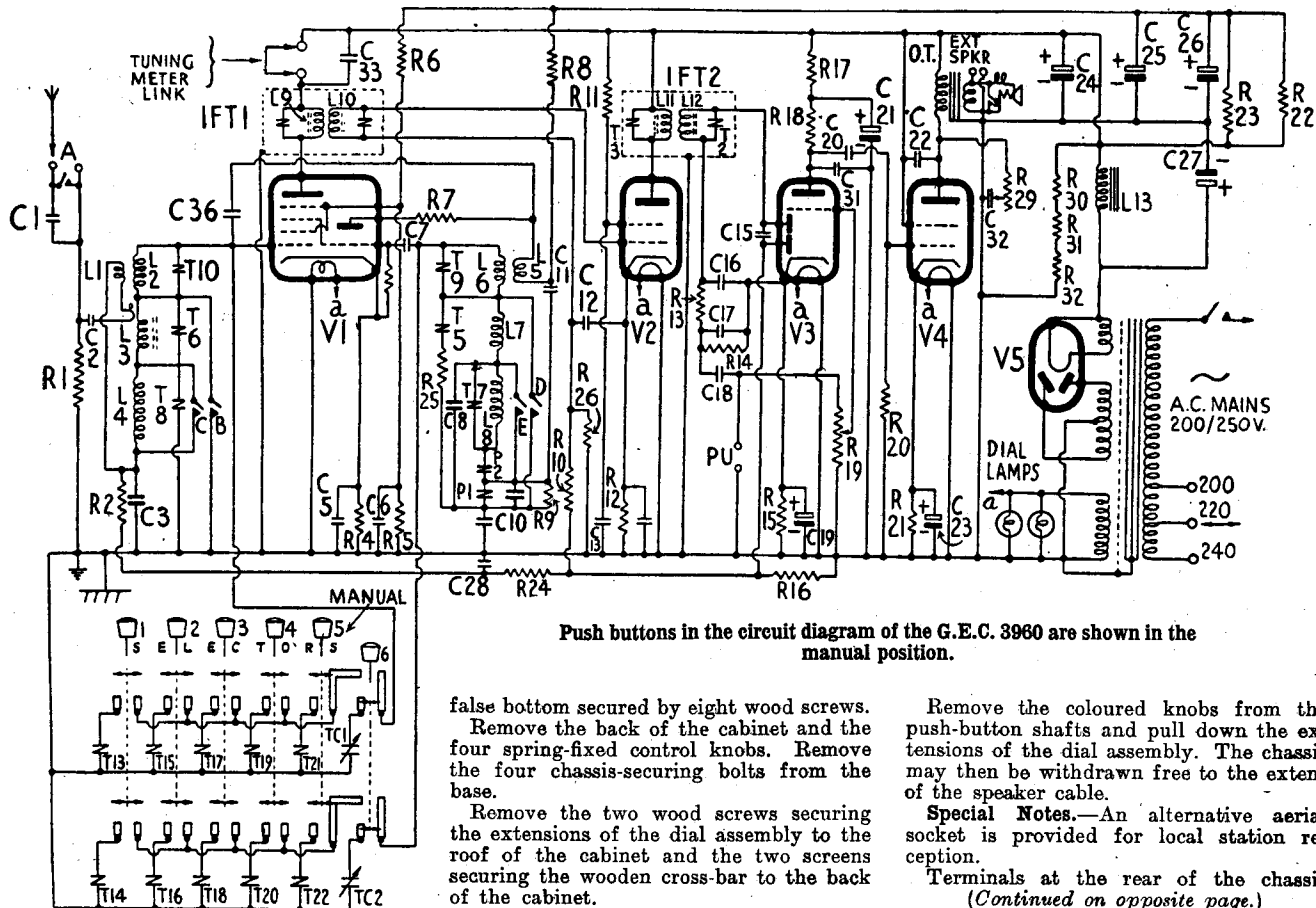

Push buttons in the circuit diagram of the G.E.C. 3960 are shown in the manual position.

false bottom secured by eight wood screws.

Remove the back of the cabinet and the four spring-fixed control knobs. Remove the four chassis-securing bolts from the base.

Remove the two wood screws securing the extensions of the dial assembly to the roof of the cabinet and the two screws securing the wooden cross-bar to the back of the cabinet.

Remove the coloured knobs from the push-button shafts and pull down the extensions of the dial assembly. The chassis may then be withdrawn free to the extent of the speaker cable.

Special Notes.—An alternative aerial socket is provided for local station reception.

Terminals at the rear of the chassis (Continued on opposite page.)

enable a low-impedance (2 to 4 ohms) extension speaker to be operated.

The mains adjustment device is covered by a metal plate at the rear of the chassis. Adjustment consists of connecting the movable link to the required voltage tapping.

There are two dial lights mounted in screw-in holders, one each side of the wavelength dial assembly. They are rated at 6.5 volts .3 amp., and have M.E.S. bases. These are prevented from working loose by adhesive tape.

Terminals at the rear of the chassis enable a pick-up to be connected.

The receiver is wired up in accordance with the G.E.C. standard colour code, the colours of the wires being: green for grids, orange for anodes, pink for cathodes, red for H.T. positive, slate for H.T. negative, earth black, and screen-grid wiring blue.

Alignment Notes

I.F. Circuits.—Switch set to M.W. band, turn gang to maximum and short-circuit oscillator gang by connecting point "X" (see layout diagram) to chassis. Turn volume control to maximum and tone to "high" position.

Connect an output meter across the primary of the output transformer (across C22). Connect a service oscillator between the top grid cap of V1 (via a .1 mfd. condenser) and chassis.

Tune the service oscillator to 456 kcs., and adjust T1, T2, T3 and T4 for maximum response, reducing the input from the oscillator as the circuits come into line. Remove short from oscillator gang (point "X").

(Continued on page 18.)

G.E.C. 3960 on Test

MODEL 3960.—For A.C. mains, 200-250 volts, 40-100 cycles. Price, £13 2s. 6d.

DESCRIPTION.—Four-valve, plus rectifier, three waveband "Touchtune" table model.

FEATURES.— Full-vision scale, coloured as to waveband, calibrated in metres and station names. Controls for concentric tuning, wave-selection, tone and combined volume and master switch. "Touchtune" push-button panel gives choice of one long wave and four medium wave stations with manual tuning. Buttons will not remain depressed unless receiver is switched to correct waveband. Terminals for pick-up and extra speaker.

LOADING.—50 watts.

Sensitivity and Selectivity

SHORT WAVES (16.5-50 metres).—Excellent gain and selectivity, very well maintained over the entire band. Easy handling, no drift.

MEDIUM WAVES (200-550 metres).—Excellent selectivity and gain, local stations only spreading over adjacent channels. Good clean background.

LONG WAVES (1,000-2,000 metres).—Good gain and excellent selectivity, Deutschlandsender being received practically clear of interference.

Acoustic Output

Ample volume for an ordinary room, with a well balanced characteristic, crisp attack, a not too vigorous tone control action and very pleasing speech reproduction.

RESISTANCES

| R. | Purpose. | Ohms. |
|----|---------------------------|---------|
| 1 | Aerial shunt | 9,000 |
| 2 | V1 A.V.C. decoupling | 99,000 |
| 3 | Osc. grid leak | 99,000 |
| 4 | V1 cathode bias shunt | 300 |
| 5 | V1 screen potr. (part) | 15,000 |
| 6 | V1 screen potr. (part) | 4,400 |
| 7 | Regeneration modifier | 150 |
| 8 | Osc. anode feed | 8,800 |
| 9 | Regeneration modifier | 5,500 |
| 10 | V2 A.V.C. potr. (part) | 2 meg. |
| 11 | V2 screen decouplings | 99,000 |
| 12 | V2 cathode bias | 400 |
| 13 | H.F. stopper | 55,000 |
| 14 | Demodulating diode load | 440,000 |
| 15 | V3 cathode bias shunt | 3,800 |
| 16 | A.V.C. diode load | 440,000 |
| 17 | V3 anode decoupling | 22,000 |
| 18 | V3 anode load | 220,000 |
| 19 | Volume control | 1 meg. |
| 20 | V4 grid leak | 440,000 |
| 21 | V4 cathode bias | 400 |
| 22 | V1 (part) H.T. decoupling | 13,000 |
| 23 | V1 (part) H.T. decoupling | 22,000 |
| 24 | V1 A.V.C. decoupling | 2 meg. |
| 25 | Regeneration modifier | 75 |
| 26 | V2 A.V.C. potr. (part) | 2 meg. |
| 29 | Tone control | 55,000 |
| 30 | H.T. bleeder | 6,800 |
| 31 | H.T. bleeder | 6,800 |
| 32 | H.T. bleeder | 8,800 |

CONDENSERS

| C. | Purpose. | Mfda. |
|----|-------------------------|----------|
| 1 | Series aerial | .00002 |
| 2 | Aerial coupling | .005 |
| 3 | V1 A.V.C. decoupling | .003 |
| 5 | V1 cathode bias shunt | .1 |
| 6 | V1 screen decoupling | .05 |
| 7 | Osc. grid | .0001 |
| 8 | L.W. osc. fixed trimmer | .00004 |
| 9 | M.W. osc. fixed padder | .0001 |
| 10 | Osc. fixed padder | .00425 |
| 11 | Osc. anode coupling | .005 |
| 12 | V2 A.V.C. decoupling | .05 |
| 13 | V2 screen decoupling | .05 |
| 14 | V2 cathode bias shunt | .1 |
| 15 | A.V.C. diode decoupling | .00004 |
| 16 | H.F. bypass | .003 |
| 17 | H.F. bypass | .0001 |
| 18 | L.F. coupling | .02 |
| 19 | V3 cathode bias shunt | .35 |
| 20 | L.F. coupling | .02 |
| 21 | V3 anode decoupling | .3 |
| 22 | Tone compensator | .005 |
| 23 | V4 cathode bias shunt | .35 |
| 24 | H.F. smoothing | .7 |
| 25 | H.T. smoothing | .3 |
| 26 | H.T. smoothing | .3 |
| 27 | H.T. smoothing | .14 |
| 28 | V1 A.V.C. decoupling | .005 |
| 31 | V3 anode shunt | .0005 |
| 32 | Tone control | .05 |
| 33 | Tuning meter shunt | .05 |
| 36 | V1 neutralising | .0000035 |

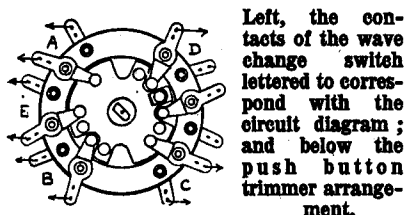

Left, the contacts of the wave change switch lettered to correspond with the circuit diagram; and below the push button trimmer arrangement.

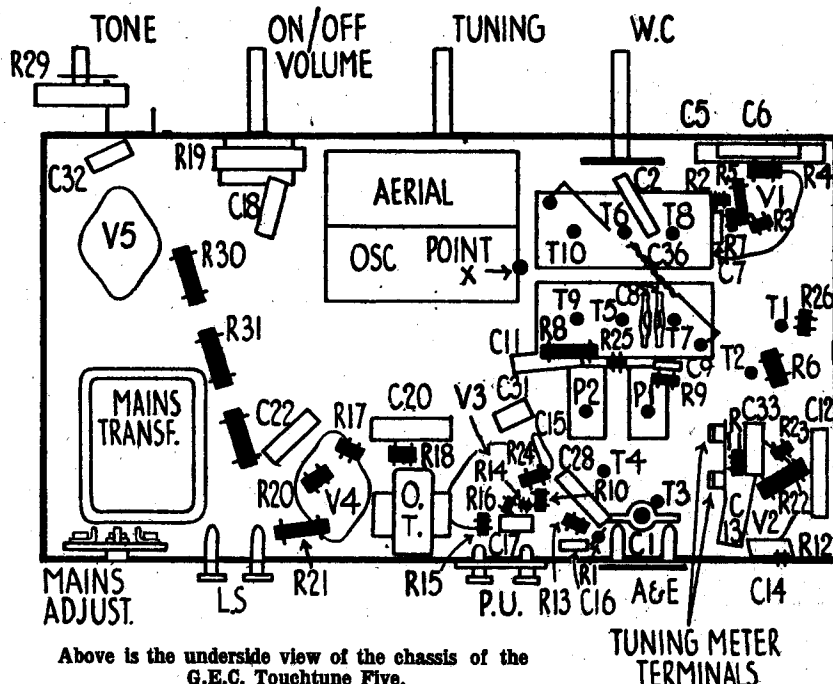
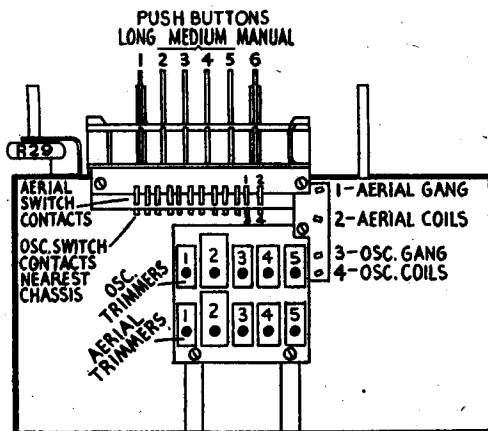

Above is the underside view of the chassis of the G.E.C. Touchtune Five.

G.E.C. Touchtune Five

(Continued from page 17.)

Signal Circuits.—Connect the service oscillator to the aerial and earth socket via a dummy aerial. Progressively reduce the input as the circuits come into line, so that the A.V.C. does not operate.

The pointer should be central in the clips and coincide with the horizontal calibration base lines when the gang is at maximum.

Medium Waves.—Tune set and oscillator to 214 metres (1,400 kcs.) and adjust T5 and then T6 for maximum.

Disconnect the lead to point "X" (see drawing) and connect an external variable condenser between the disconnected lead and chassis.

Tune service oscillator to 500 metres (600 kcs.) and adjust the external variable condenser and receiver tuning control simultaneously for maximum response.

Disconnect external variable condenser, reconnect oscillator tuning condenser and, without altering receiver tuning control, adjust P1 for maximum response.

Long Waves.—Tune set and oscillator to 1,000 metres (300 kcs.) and adjust T7 and then T8 for maximum.

Disconnect the lead from point "X" and connect external variable condenser as before.

Tune service oscillator to 1,818 metres (165 kcs.) and adjust external condenser and receiver tuning control simultaneously for maximum.

Disconnect external condenser, reconnect oscillator tuning condenser as before and, without adjusting the receiver tuning control, adjust P2 for maximum.

Repeat 1,000 metres (300 kcs.) operation to ensure correct calibration.

Short Waves.—Tune set and oscillator to 16.7 metres (18 mcs.), screw T9 up, unscrew until the second peak from "tight" is heard, and then adjust T10 for maximum while rocking the gang.

Replacement Condensers

An exact replacement is available from A. H. Hunt Ltd., Garratt Lane, Wands-worth, London, S.W.18, for the block containing Cs 27, 24, 21, 25, 26, 19 and 23. Unit list number 4217, this sells at 15s. 6d.

Alba Model 90

(Continued from page 54.)

leads to enable most small adjustments to be carried out without removing the speaker. The speaker is, however, easily detached by releasing the four retaining nuts.

If the leads are unsoldered from the speaker strip the colours for reconnection are as follows: The frame of the speaker is white, unsmoothed H.T. blue, smoothed H.T. red, output anode black.

Special Notes.—In some chassis a .1 mfd. condenser is connected across the H.T. This is shown in the model we examined as C25, but it may be missing in certain receivers. In the model examined, B1 (V1 A.V.C. decoupling) has a value of 200,000 and not 250,000 ohms. Similarly R13 is likewise 200,000 ohms instead of the nominal value.

The somewhat unusual trimmer arrangement should be noted in which T1 is located on the condenser gang and is therefore in operation on all ranges. T2 the medium-wave input trimmer, will be found supported in the wiring beneath the chassis and is therefore not accessible without removing the chassis.

The three trimmers for the oscillator are acces-

Parts on the top of the G.E.C. chassis are identified by this layout diagram. The underchassis diagram is on the previous page adjoining the circuit drawing and component tables.

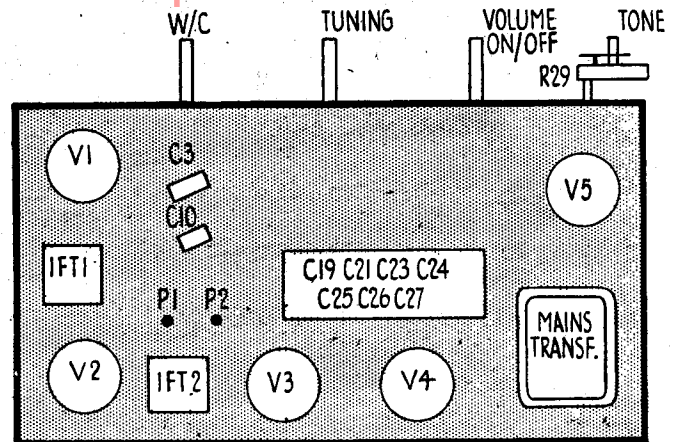

Push Button Adjustment

TO set the buttons, connect an aerial and earth system to the receiver, switch on receiver and allow to run for at least 15 minutes. Remove shorting link from tuning meter terminals (see drawing) and connect 0.5 or 0.10 ma. meter across the terminals.

Set wave-change switch to appropriate waveband, depress manual tuning control button, tune in required station, and note meter reading at correct resonance point.

Depress appropriate button and adjust corresponding oscillator trimmer, and then aerial trimmer, for maximum response in speaker and for the lowest tuning meter reading.

Manual Check

During the adjustment, check that the desired station is being obtained by switching to manual tuning and back again to the push button. If more than one station is transmitting the same programme the correct adjustment of the trimmers may be checked by ensuring that the meter reading corresponds approximately to that obtained on manual tuning.

After all desired stations have been set up, disconnect tuning meter, replace shorting link, and fit buttons with correct station names.

Should it be found upon depressing a button that the one previously operated is sluggish in returning to normal, the guide slots may have become dry and require lubricating with vaseline or thick oil.

Switch Wire

If it is found upon pressing any button on its appropriate waveband it fails to remain depressed, the brass wire coupling the wave-change switch rod to the release bar may have stretched or become bent.

The range over which the trimmers may be adjusted is as follows:—Long waves, button 1 = 1,250-1,625 metres; medium waves, button 2 = 215-280 metres, button 3 = 260-320 metres, button 4 = 295-390 metres, button 5 = 380-510 metres.

The range of button 2 may, if desired, be extended to below 215 metres by substituting a ceramic washer for the upper brass washer on the oscillator and aerial trimmers corresponding to the button. Suitable ceramic washers will be found fixed to the cross batten in the base of the cabinet.

The tuning range of button 5 may be extended if desired by connecting two .0001 mfd. silvered mica condensers across the corresponding trimmers.

sible from the side of the oscillator coil can. The correct position of these is as shown in the sketch, and not as in the makers' leaflet, which shows two long-wave trimmers.

Wave-change Switches.—The wave-change switch arrangement is a little confusing because, although one wafer has four wipes and provides for four different positions, there are only 12 contacts. Actually, in the gramophone position the various wipes move on to the contact belonging to the next set of contacts.

The change-over from gramophone to radio is provided by the second wafer, which is mounted nearest to the click plate. There are three wipes on this wafer, two of them going to the points shown in the diagram, and the third is connected to the chassis.

It will also be observed that the switch representations in the diagram do not show the various contacts which are actually linked together. For the sake of simplicity only the active contacts are marked on the switch diagrams in the main circuit, these markings showing all the relevant points which might be required for service work.

Alignment Notes

I.F. Circuits.—Connect the signal generator to the grid of V2 and adjust it to 465 kc. Adjust

T9 and T8 for maximum response on an output meter.

Then connect the signal generator to the control grid of V1 and adjust T7 and T6. Work with the smallest possible input and reduce this as the circuits come into line.

Medium Waves.—Connect oscillator to aerial and earth of receiver through a dummy aerial.

Tune the set and oscillator to 250 metres and adjust T4 and then T1 for maximum response.

Tune the set and oscillator to 500 metres and adjust P1 for maximum simultaneously rocking the gang. Repeat operations until no further improvement results.

Long Waves.—Tune the set and oscillator to 1,200 metres and adjust T5 and T2 for maximum output.

Then tune the set and oscillator to 1,900 metres and adjust P2 for maximum, simultaneously rocking the gang.

Repeat the operations until no further improvement results.

Short Waves.—Tune the set and oscillator to 20 metres and adjust T3 for maximum, using the peak obtained with the trimmer nearest its minimum position.

The aerial trimmer, T1 should not be moved, and there is no padding operation as the padder is fixed.