

"TRADER" SERVICE SHEET

482

H.M.V. 1404

MARCONIPHONE 892



The H.M.V. 1404 receiver. The Marconiphone 892 has an identical chassis.

THE H.M.V. 1404 table receiver is a 3-band battery superhet employing four valves of the 2 V type. A special feature is a battery economiser switch which inserts a resistance in the main HT positive lead when full power is not required. The total HT consumption is 10 mA under full power conditions, and 5 mA under economy conditions. Grid bias is automatic. The SW range is 16.5 to 50 metres, and press-buttons are employed for waveband switching.

The Marconiphone model 892 is identical as far as the chassis is concerned. Release date, both models, April, 1940.

CIRCUIT DESCRIPTION

Aerial input via high impedance coupling circuits C1, L1 (SW), L2 (MW) and L3, C2 (LW) to single tuned circuits L4, C20 (SW), L5, C20 (MW) and L6, C20

(LW). The coupling circuits are permanently connected, and resistance R1 is permanently shunted across them, but L3 is short-circuited by S3x on SW and MW.

The switches have been numbered to correspond with the press-buttons controlling them, and coded with lettered suffixes to indicate their action. All switches numbered S1 are operated by the SW button; those numbered S2 by the MW button; and those numbered S3 by the LW button.

If the suffix letter is a, b, or c, the switch closes when its button is pressed; otherwise it remains open. If the suffix letter is x, y, or z, the switch opens when the button is pressed, but remains closed on the other bands.

First valve (V1, Marconi metallised X24) is a triode hexode operating as frequency changer with internal coupling. Triode oscillator grid coils L7 (SW), L8 (MW) and L9 (LW) are tuned by C22. Parallel trimming by C23 (MW) and C24 (LW); series tracking by C8 (SW), C6 (in high potential lead from L8 via S2c, MW) and C6, C7 (LW) where C6 is again in high potential lead, via S3c, and C7 is in the normal position. Tracking corrections are carried out by inductance adjustment, by movable iron-cores in the case of the MW and LW coils, and by loose end-turn loops, in the aerial and oscillator circuits, on the SW band.

Reaction by coupling coil L10, via small coupling condenser C9 (SW), coupling coil L11 (MW), and the tracker C7 (LW) which is common to grid and anode cir-

cuits and forms a coupling impedance.

When the SW press-button is pressed, S1c closes to connect R5 across R6 so that the oscillator anode feed resistance is lowered and the anode voltage is raised.

Second valve (V2, Marconi metallised Z21) is a variable-mu RF tetrode operating as intermediate frequency amplifier with tuned-primary, tuned-secondary iron-core transformer couplings C25, L12, L13, C26 and C27, L14, L15, C28.

The iron-cores are fixed and alignment is carried out in the usual manner by adjustment of the pre-set tuning condensers.

Intermediate frequency 465 KC/S.

Diode second detector is part of double diode triode valve (V3, Marconi metallised HD24). Audio frequency component in rectified output is developed across load resistance comprising the manual volume control R9 and its limiting resistance R8 and passed via AF coupling condenser C14 and CG resistance R10 to control grid of triode section, which operates as audio frequency amplifier. IF filtering by by-pass condensers C12 (in diode circuit) and C15 (in triode anode circuit).

Second diode of V3, fed from V2 anode via C13, provides DC potentials which are developed across load resistances R12, R13 and R14 and fed back through decoupling circuits as GB to FC (except on SW) and IF valves, giving automatic volume control. R17 is effectively in parallel with R13, R14.

Resistance-capacity coupling by R11, C16 and R15 between V3 triode and tetrode output valve (V4, Marconi KT2).

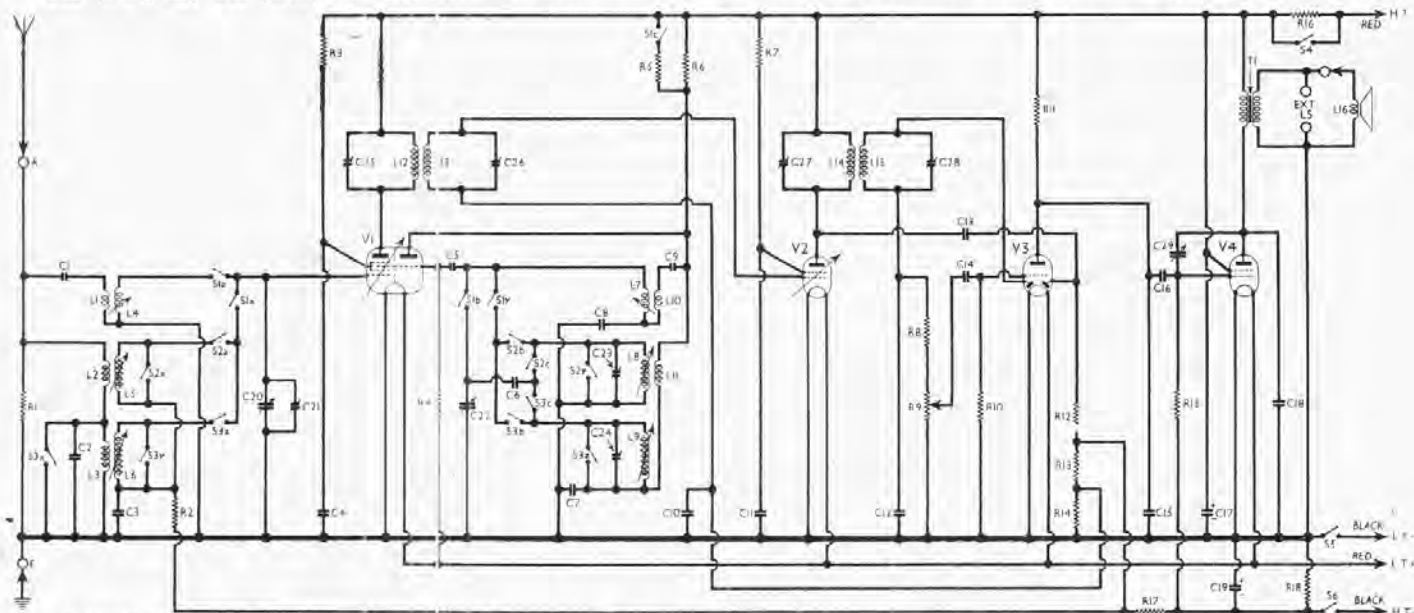

Circuit diagram of the H.M.V. 1404 and Marconiphone 892 receivers. Press-button wavechange switching is used. S4 is the economiser switch operated from the rear of the chassis. C29, from anode to grid of V4, is the tone control condenser.

Plan view of the chassis. Only the two IF units, with their trimmers, and the output transformer **T1** are mounted on this side of the chassis.

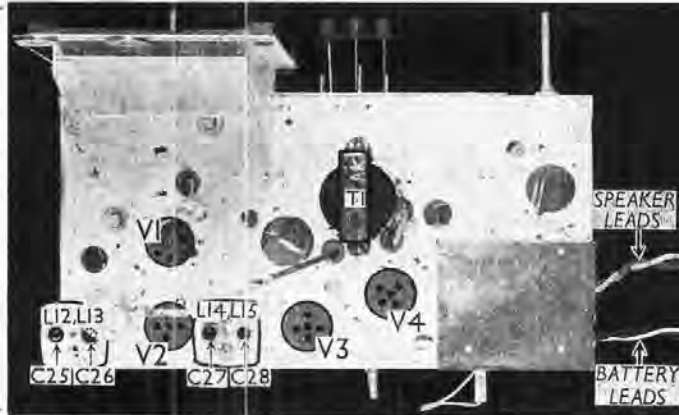

Variable tone control by variable condenser **C29** connected between anode and control grid. Fixed tone correction by **C18** between anode and chassis.

GB potential for **V4** is obtained automatically from drop along resistance **R18** in negative HT lead to chassis. Fixed GB potentials for **V1** and **V2** are tapped off from potential divider comprising resistances **R17**, **R13** and **R14**, which are connected across **R18**. **R18** is by-passed by electrolytic condenser **C19**.

COMPONENTS AND VALUES

RESISTANCES		Values (ohms)
R1	Aerial circuit shunt ...	10,000
R2	V1 hexode CG decoupling ...	230,000
R3	V1 SG HT feed ...	50,000
R4	V1 osc. CG resistance ...	100,000
R5	V1 osc. anode HT feed ...	15,000
R6	resistances ...	50,000
R7	V2 SG HT feed ...	75,000
R8	Volume control limiter ...	230,000
R9	Manual volume control; V3 signal diode load ...	500,000
R10	V3 triode CG resistance ...	2,300,000
R11	V3 triode anode load ...	150,000
R12	V3 AVC diode load ...	230,000
R13	V3 AVC diode load resistances ...	2,300,000
R14	350,000
R15	V4 CG resistance ...	350,000
R16	Battery economiser resistance ...	10,000
R17	Part V1, V2 GB pot. divider ...	2,300,000
R18	Auto GB resistance ...	350

CONDENSERS		Values (μF)
C1	Aerial SW series condenser ...	0.000035
C2	Aerial LW shunt condenser ...	0.0005
C3	V1 hexode CG decoupling ...	0.05
C4	V1 SG decoupling ...	0.05
C5	V1 osc. CG condenser ...	0.000075
C6	Osc. circuit MW tracker ...	0.0005
C7	Osc. circuit LW tracker ...	0.00035
C8	Osc. circuit SW tracker ...	0.005
C9	V1 osc. anode SW coupling ...	0.00005
C10	V2 CG decoupling ...	0.05
C11	V2 SG decoupling ...	0.05
C12	IF by-pass ...	0.0001
C13	Coupling to V3 AVC diode ...	0.0001
C14	AF coupling to V3 triode ...	0.01
C15	IF by-pass ...	0.00023
C16	V3 triode to V4 AF coupling ...	0.05
C17*	HT reservoir condenser ...	8.0
C18	Fixed tone corrector ...	0.001
C19*	Auto GB circuit by-pass ...	50.0
C20†	Aerial circuit tuning ...	—
C21†	Aerial circuit MW trimmer ...	—
C22†	Oscillator circuit tuning ...	—
C23†	Osc. circuit MW trimmer ...	—
C24†	Osc. circuit LW trimmer ...	—
C25†	1st IF trans. pri. tuning ...	—
C26†	1st IF trans. sec. tuning ...	—
C27†	2nd IF trans. pri. tuning ...	—
C28†	2nd IF trans. sec. tuning ...	—
C29†	Variable tone control ...	0.0001

* Electrolytic. † Variable. ‡ Pre-set.

OTHER COMPONENTS		Approx. Values (ohms)
L1	Aerial SW coupling coil ...	0.7
L2	Aerial MW coupling coil ...	24.0
L3	Aerial LW coupling coil ...	59.0
L4	Aerial SW tuning coil ...	Very low
L5	Aerial MW tuning coil ...	2.25
L6	Aerial LW tuning coil ...	17.5
L7	Osc. circuit SW tuning coil ...	Very low
L8	Osc. circuit MW tuning coil ...	3.0
L9	Osc. circuit LW tuning coil ...	7.5
L10	Oscillator SW reaction coil ...	0.8
L11	Oscillator MW reaction coil ...	1.75
L12	1st IF trans. { Pri. ...	4.5
L13		Sec. ...
L14	2nd IF trans. { Pri. ...	4.5
L15		Sec. ...
L16	Speaker speech coil ...	100
T1	Output trans. { Pri. ...	650.0
	{ Sec. ...	0.4
S1a, b, c, x, y to S3a, b, c	Waveband switches ...	—
S4	Battery economiser switch ...	—
S5	LT circuit switch ...	—
S6	HT circuit switch ...	—

DISMANTLING THE SET

Removing Chassis.—Remove the two control knobs (self-tapping screws) from the front of the cabinet; remove the tone control knob (pull-off) from the side of the cabinet; remove the four bolts (with lock-washers and claw washers) holding the chassis to the bottom of the cabinet.

The chassis may now be withdrawn to the extent of the speaker leads and tone control leads, which is sufficient for normal purposes.

To free the chassis entirely, unsolder from the small connecting panel on the speaker the two leads connecting it to chassis;

remove the tone control condenser **C29** from its bracket by unscrewing its fixing nut, if a suitable box spanner is available; otherwise remove **C29** together with its mounting bracket by unscrewing the four round-head wood screws holding the bracket to the side of the cabinet.

When replacing, connect the yellow speaker lead to the tag marked + on the small connecting panel, and the grey lead to the tag marked -.

Removing Speaker.—Remove the four round-head wood screws (with

washers) holding the speaker to the sub-baffle.

When replacing, see that the connecting panel is at the top, and connect the leads, if they have been disconnected, as indicated above.

Press-Button Switch Unit.—This unit can only be viewed from the underside of the chassis, and while it remains in position the upper side of the unit cannot be seen.

To gain access to the upper side of the unit, remove the four self-tapping screws holding the large metal plate, on which the complete tuning assembly is mounted, to the front member of the chassis. The assembly may then be eased into a position from which it can be turned over towards the rear of the chassis without disconnecting its leads, thus exposing the upper side of the switch unit.

VALVE ANALYSIS

Valve voltages and currents given in the table below are those measured in our receiver when it was operating with a new HT battery reading 120V on load.

The receiver was tuned to the lowest wavelength on the MW band. The volume control and battery economiser were at maximum, but there was no signal input.

Voltages were measured on the 400V scale of a model 7 Universal Avometer, chassis being negative.

Valve	Anode Voltage (V)	Anode Current (mA)	Screen Voltage (V)	Screen Current (mA)
V1 X24	{ 117 50	{ 0.7 1.3	70	0.9
V2 Z21	117	0.9		
V3 HD24	57	0.35	83	0.35
V4 KT2	112	4.6	117	0.9

GENERAL NOTES

Switches.—S1a, b, c, x, y to S3a, b, c, x, y, z are the waveband switches in a 3-section double-sided press-button unit beneath the chassis. This is indicated in our under-chassis view, and two diagrams of it are overleaf. The upper one of these is the view as seen looking at the underside of the chassis, while the lower one shows the side of the unit facing the chassis deck.

As explained at the beginning of the Circuit Description, all the switches controlled by each press-button have the same number, S1 being associated with the SW button, S2 with the MW button and S3 with the LW button. The suffixes denote the action of the switches. All the a, b and c switches close when their button is pressed; all the x, y and z switches open when their button is pressed. Note especially S1c, which closes when the SW button is pressed, paralleling R5 with R6 and so increasing the oscillator anode volts on SW.

S4 is the battery economiser switch, of the rotary type, fitted on the rear chassis member. In the anti-clockwise position of its knob (Economy) the switch is open; in the clockwise position (Maximum) it is closed.

S5, S6 are the LT and HT circuit switches, in a QMB unit, ganged with the volume control R9.

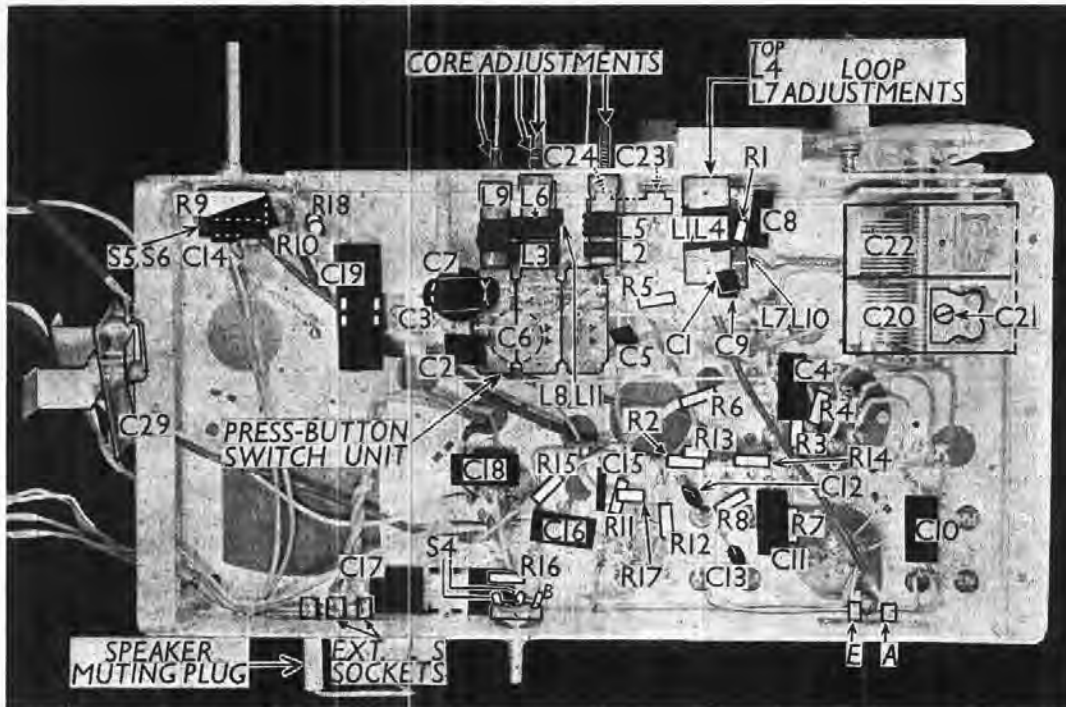

Under-chassis view. C29, on the left, is the tone control condenser, normally fitted at the left-hand side of the cabinet. The S5, S6 unit is ganged with R9. R10 is above R18. C23 and C24 are adjusted through holes in the front chassis member, as are also the loops of L4 and L7. S4 is the battery economiser switch.

Coils.—L1, L4; L2, L5; L3, L6; L7, L10; L8, L11 and L9 are in six unscreeded tubular units fitted behind the front chassis member. In the case of the L1, L4 and L7, L10 units, L4 and L7 are the thick wire windings, and they are provided with inductance adjustment loops inside their formers, which can be reached through holes in the front chassis member. All the other units have adjustable iron cores, their adjusting screws being at the front of the chassis.

The IF transformers L12, L13 and L14, L15 are in two screened units on the chassis deck, with their associated trimmers.

External Speaker.—Two sockets are provided at the rear of the chassis for a low

resistance (3 to 5 Ω) external speaker. A third socket is provided, into which a plug on a flying lead is normally fitted. When this plug is withdrawn L16 is disconnected and the internal speaker is muted.

Tone Control.—This is a variable condenser (C29) fitted at the left-hand side of the cabinet. It is shown on the left of our under-chassis view.

Batteries.—LT, Exide 2V 24AH glass-cased accumulator cell; HT, Marconiphone 114V + 6V (120V overall) HT dry battery.

Battery Leads and Voltages.—Black lead, spade tag, LT negative; red lead, spade tag, LT positive 2V; black lead and plug, HT negative in negative 6V socket; red lead and plug, HT positive 120V, in positive 114V socket.

Trimmers.—Apart from the coil loop and core adjustments already mentioned, there is one trimmer on the gang condenser, two in a dual unit adjustable through holes in the front chassis member, and the four IF trimmers, two in each screened unit on the chassis deck.

Chassis Divergencies.—The tone control condenser is not shown in the makers' diagram. C18 was 0.001 μ F in our chassis, but is shown as 0.0015 μ F by the makers.

CIRCUIT ALIGNMENT

IF Stages.—Press MW button, turn volume control and economiser switch to maximum, and gang condenser to minimum. Connect signal generator, via a 0.1 μ F condenser to control grid (top cap) of V1 and chassis, leaving existing top cap connection in position.

Feed in a 465 KC/S signal, and adjust C28, C27, C26 and C25 in turn for maximum output. Check these adjustments.

RF and Oscillator Stages.—With gang at minimum, pointer should coincide with the 192 m mark on the MW scale. If not, slide the pointer up or down the

drive wire until it is in the correct position. Connect signal generator to A and E sockets, via a suitable dummy aerial. Volume control and economiser switch should be at maximum.

MW.—Press MW button, turn gang to minimum, feed in a 192 m (1,562 KC/S) signal and adjust C23 (through front of chassis) for maximum output. Tune to 220 m on scale, feed in a 220 m (1,364 KC/S) signal, and adjust C21 (on gang) for maximum output. Tune to 530 m on scale, feed in a 530 m (566 KC/S) signal, and adjust cores of L8 and L5 for maximum output. Repeat these adjustments several times.

LW.—Press LW button, tune to 720m on scale, feed in a 720m (417 KC/S) signal, and adjust C24 for maximum output. Tune to 1,750m on scale, feed in a 1,750m (171.4 KC/S) signal and adjust core of L9 for maximum output. Tune to 1,400m on scale, feed in a 1,400m (214.3 KC/S) signal, and adjust core of L6 for maximum output. Repeat the 720m adjustment.

SW.—Press SW button, tune to 50m on scale, feed in a 50m (6 MC/S) signal, and adjust the loops of wire inside the L7 and L4 coil formers, through holes in the front of the chassis. A special hooked tool of insulation material should be used, and the loops should be adjusted for maximum output. Repeat these adjustments several times, then check that the set will tune down to 16.8m.

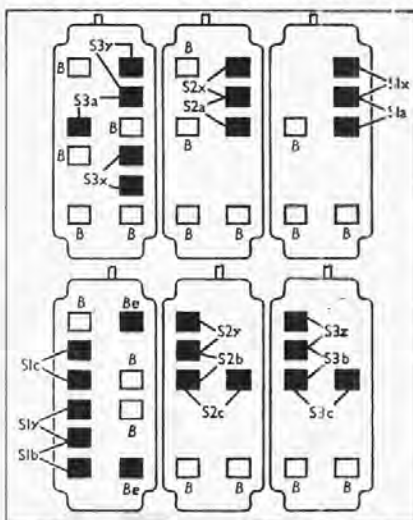

Two views of the press-button switch unit. Top, the side seen from beneath the chassis; bottom, the side facing the chassis deck.

Service Sheet Index

Radio Servicemen who want to look up quickly just what receivers have been covered by The Trader series of Service Sheets should consult the last complete index on pages 234 and 235 of the June 29 issue.