

MARCONIPHONE T19A

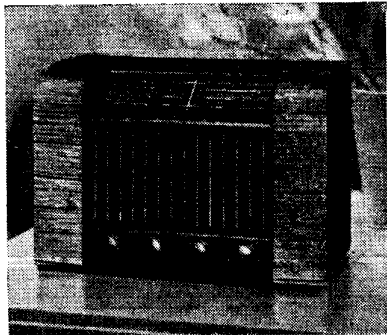

Five-valve three-waveband superhet with three pre-selected stations, internal plate aerial and sockets for external aerial, earth, high-resistance pickup and low-impedance extension speaker. For 195-255V 50-100 c/s AC mains. Walnut veneer cabinet. Marketed by Marconiphone Co., Ltd., Hayes, Middlesex.

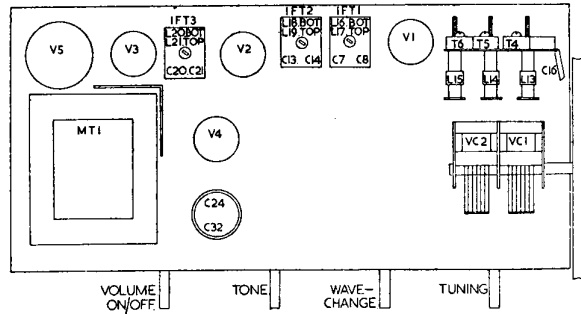

WAVECHANGE SWITCH

VIEWED REAR OF UPRIGHT CHASSIS

S1 S2 S3

S4 S5 S6 S7

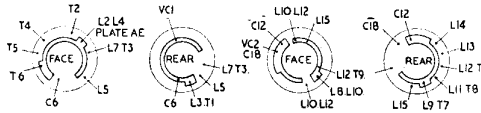

SWITCH SHOWN IN SW POSITION

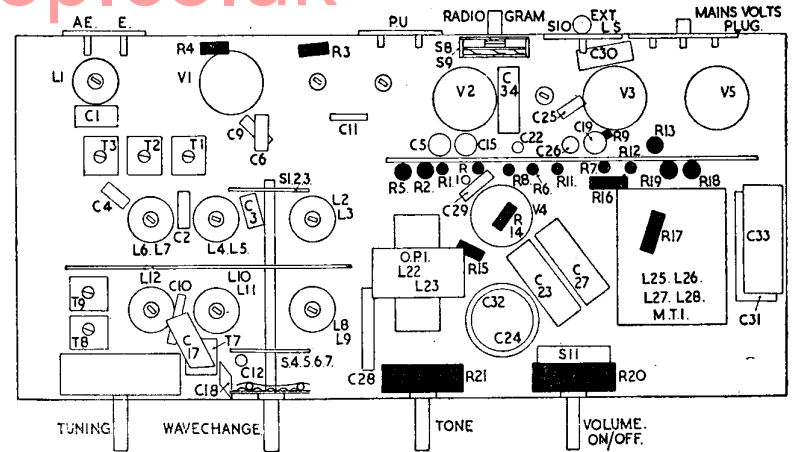

CAPACITORS

C	Capacity	Type
1	100pF	Silver Mica
2	100pF	Tub. Ceramic
3	5pF	Silver Mica
4	30pF	Tub. Ceramic
5	.05	Tubular 500V
6	100pF	Tub. Ceramic
7	100pF	Silver Mica
8	100pF	Silver Mica
9	100pF	Tub. Ceramic
10	100pF	Silver Mica
11	2pF	Silver Mica
12	100pF	Tub. Ceramic
13	100pF	Silver Mica
14	100pF	Silver Mica
15	.05	Tubular 500V
16	350pF	Silver Mica

C	Capacity	Type
17	350pF	Silver Mica
18	500pF	Silver Mica
19	.05	Tubular 500V
20	100pF	Silver Mica
21	180pF	Silver Mica
22	100pF	Tub. Ceramic
23	.02	Tubular 1000V
24	16	Electrolytic 450V
25	50pF	Tub. Ceramic
26	.02	Tubular 750V
27	.1	Tubular 350V
28	350pF	Mica
29	100pF	Tub. Ceramic
30	.001	Tubular 750V
31	50	Electrolytic 25V
32	24	Electrolytic 450V
33	16	Electrolytic 450V
34	.02	Tubular 750V

RESISTORS

R	Ohms	Watts
1	47K	1/4
2	22K	1/4
3	680K	1/4
4	33K	1/4
5	27K	1/4
6	100K	1/4
7	1.5M	1/4
8	470K	1/4
9	10K	1/4
10	1M	1/4
11	150K	1/4
12	1.5M	1/4
13	2.2K	1/4
14	1M	1/4
15	10M	1/4
16	47...	1/4
17	33...	1/4
18	1K	1
19	1K	1
20	2M Potr. with switch	1
21	500K	Potr.

INDUCTORS

L	Ohms
1	200
2	Very Low
3	Very Low
4	40
5	2
6	150
7	17
8	.5
9	Very Low
10	1
11	2.5
12	5
13	1.5
14	2.5
15	5
16-21	7.5
22	500
23	.4
24	3.5
25	Very Low
26	380 Total
27	Very Low
28	35 Total

Description and alignment notes, see opposite

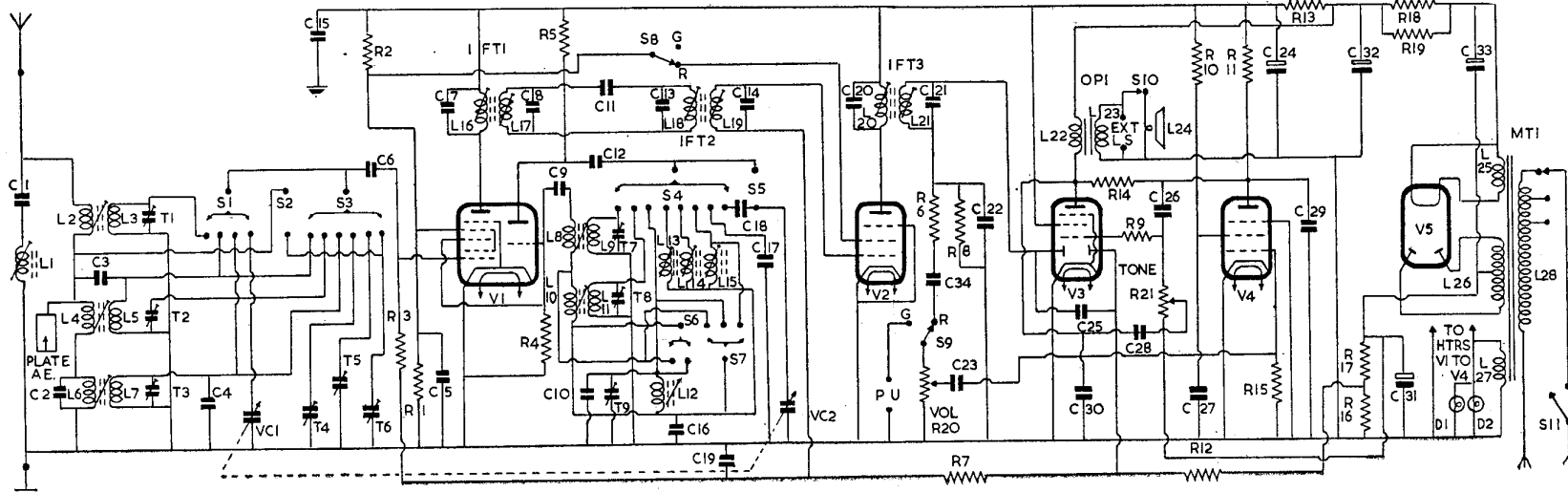
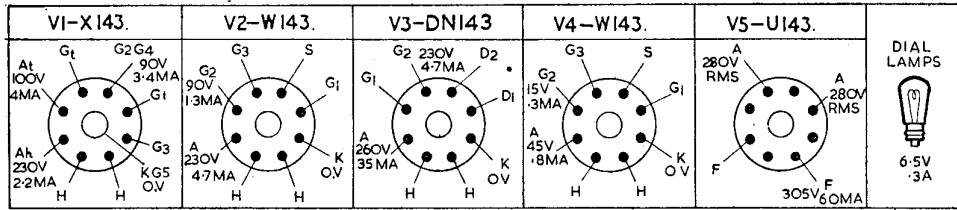

AERIAL is fed to series-connected coupling coils L2 (SW), L4 (MW), L6 (LW) and to IF filter L1, C1. Plate aerial for MW and LW reception, which is formed by metal grille of loud-speaker, is coupled to MW coil L4. Image rejection on LW band is effected by L4, C2.

Grid coils L3 (SW), L5 (MW), L7 (LW), which are trimmed by T1, T2, T3, C4, are connected by S1 to tuning capacitor VC1 and through C6 to g1 of triode-heptode frequency changer V1. C3 provides additional capacitive coupling between L4, L5. S2, which is closed only on SW band, shunts T6 across L4, L6.

On pre-selected stations trimmers T4, T5, T6 are connected by S3 across L5, L7 and VC1 is disconnected from circuit by S1. AVC and a standing bias, decoupled by R7, C19, are fed by R3 to V1.

Screen (g2, g4) voltage is obtained from potential divider R1, R2 and is decoupled by C5. Suppressor grid is internally strapped to cathode. L16, C7, the primary of IFT1, is in the heptode anode circuit.

Oscillator is connected in a shunt-fed tuned-anode circuit. The anode coils L9 (SW), L11 (MW), L12 (LW), which are trimmed by T7, T8, T9, C10, are switched by S4, S5 to tuning capacitor VC2 and through C12 to oscillator anode of V1. R5 is anode load. C18, which is connected in series with VC2 on MW and LW bands, is short circuited by S4 on SW band.

On pre-selected stations L13, L14, L15, which are permeability tuned, are switched by S4 to capacitor C17 and through C12 to oscillator anode. S6, S7 short out the unused coils.

Grid reaction voltages, which are developed inductively on L8 (SW), L10 (MW) and capacitively on C16 for LW and pre-selected stations, are fed by C9 to oscillator grid. Automatic bias for grid is developed on C9 with R4 as leak resistor.

IF amplifier operates at 465 kc/s. L17, C8, the secondary of IFT1, is coupled by C11 to primary L18, C13 of IFT2. Secondary L19, C14 then feeds signal, AVC voltages and a standing bias, decoupled by R7, C19, to IF amplifier V2.

Screen (g2) voltage is obtained through S8 from potential divider R1, R2 and decoupled by C5. In the gram position of S8 the screen voltage to V2 is disconnected. L20, C20, the primary of IFT3, is in the anode circuit.

Signal rectifier. Secondary L21, C21 of IFT3 feeds one diode of V3. R8 is the load. Rectified signal is fed through filter R6, C22 and C34 to S9, which in the "Radio" position, passes it to the volume control R20.

Pickup. Sockets are fitted for connection of a high resistance pickup. In "Gram" position of S9 pickup signal is fed to volume control R20. S8, which is ganged to S9, disconnects the screen voltage from IF amplifier V2 to prevent radio breakthrough.

AVC. C25 feeds signal from secondary of IFT3 to second diode of V3. R12, its load, is connected to bias network R16, R17 to provide delay voltage.

AF amplifier. C23 feeds signal from volume control R20 to grid of AF amplifier V4. Bias is developed by C23, R15. R11 is anode load.

Output Stage. C26 feeds through stopper R9, the output pentode section of V3. Bias is obtained

from R16, R17, decoupled by C31, and is fed through R21 to grid.

L22, the primary of output transformer OPI, is in the anode circuit, the HT for which is obtained from junction of R13, R18. Negative feedback from anode V3 is applied through R14, C26, R9 to its grid. C28, C30, R21 give variable feedback for tone control. Secondary L23 of OPI feeds signal to a 6 1/2 inch PM loudspeaker L24. Sockets are fitted on L23 for connection of a low-impedance extension speaker. S10 enables the internal speaker to be silenced.

HT is provided by a directly heated, full-wave rectifier V5. L26, the HT secondary of mains input transformer MTL, supplies its anode voltages and L25 its filament current. R13, R18, R19, with C24, C32, C33, give resistance capacity smoothing and C15, RF decoupling.

Bias for grids V1, V2, V3 and AVC delay voltage is developed by R16, R17 in the negative HT lead to chassis. C31 is bias decoupling capacitor.

Heaters of V1 to V4 and dial lights obtain their current from L27. L28, the primary of MT1, is tapped for input voltages of 195-215, 216-235, 236-255 Volts 50-100 cycles AC.

Chassis Removal. Remove four control knobs on front and radio-gram knob at rear. Remove back panel and loosen screw holding aerial lead tag (on loudspeaker baffle). Unclip dial lights from their brackets. Slacken screw clamping dial cord to cursor and slip cord free. Remove four chassis bolts.

ALIGNMENT INSTRUCTIONS

Apply signal as stated below	Tune Receiver to	Trim in Order stated for Max. Output
(1) 465 kc/s via .1 mF to g1 of V2	MW band with gang condenser at minimum capacity	Core, L21, L20
(2) 465 kc/s via .1 mF to g1 of V1	—	Core L19, L18, L17, L16
(3) 465 kc/s to AE. E sockets	—	Core L1 for min.
(4) 18 mc/s to AE E sockets via dummy aerial	18 mc/s on drive wheel	T7, T1
(5) 6 mc/s as above ...	6 mc/s	Core L9, L3. Repeat (4) and (5)
(6) 600 kc/s as above...	600 kc/s	T8, T2
(7) 1.3 mc/s as above.	1.3 mc/s	Core L11, L5. Repeat (6) and (7)
(8) 300 kc/s as above...	300 kc/s	T9, T3
(9) 160 kc/s as above...	160 kc/s	Core L12, L7. Repeat (8) and (9)
Pre-selected Stations		
(10) 240 kc/s-150 kc/s as above	Switch 1	Core L15, T6
(11) 909 kc/s-536 kc/s as above	Switch 2	Core L14, T5
(12) 1.5 mc/s-877 kc/s as above	Switch 3	Core L13, T4

Check on signal from stations and re-adjust if necessary.

CREDA

COOKERS—

from page 37.

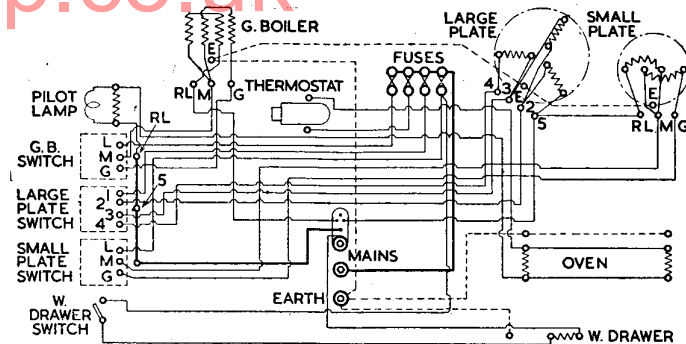

Fig. 7. Wiring diagram of model EV13 with warming drawer. The EV13 without drawer and EV12 with two plates, are similar but for the omission of certain elements and switches

Mains wiring within the cooker is carried out with heavy gauge flameproof insulated wire. A theoretical circuit diagram of the wiring is shown in Fig. 7.

MAINTENANCE

Before any maintenance is attempted make sure the cooker main wall switch is off.

Removal of plates and grill. Lower splash plate so that it lies on surface of hob. Open hot-cupboard door and undo wing nut at front underside of hob. Raise hob until it locks in upright position. Lift boiling-plates and grill-boiler out—keeping them level so as not to put strain on plug pins.

Removal of fuses. Raise hob as above and remove two screws of fuse box cover plate to expose porcelain fuse holders (Fig. 3).

Removal of oven elements. Withdraw shelves. Remove oven side panels by raising lower edge inwards and upwards until panel is free to lift off support rail. Remove base tray by tilting and sliding forward. The oven elements can now be withdrawn (Fig. 5) by unplugging.

Removal of pilot lamp. Remove the pilot lamp housing by carefully easing it from its aperture. Separate lampholder from housing, renew bulb (3.5V), replace in housing and press back into position.

Removal of warming drawer element. Pull drawer outwards until stop engages. Tilt drawer and lift clear of stop. Drawer can then be entirely removed from its compartment. Heating element (Fig. 5) which is similar in type to that used in the oven, but of a different shape and wattage, can then be unplugged.

Access to wiring. Side panels are each secured by three screws on the back flange. On removal of these screws, side panels can be lifted away. In certain cases it may be necessary to remove the back panel as well. To do this remove the screws at bottom.

Removing thermostat (Fig. 6). Loosen two screws on adjustable coupling rod E between control knob assembly and thermostat and slide couplers out of connectors. Remove the two leads to thermostat terminals—undo bolts holding thermostat to side of oven and carefully withdraw. When replacing see that thermostat is seated properly and that calibration of control knob is in accordance with its original setting. The control knob is set one division (25° F) lower than the thermostat calibration.

Height adjustment. The hob height is adjustable over approximately one inch for alignment with built-in kitchen equipment. Close splash-plate down on hob and lift up hob until it locks in its vertical position. Loosen hinge pin locking nut (Fig. 3) and slacken off locking screws situated at top of rear panel (Fig. 6). Adjust height of hob by turning lower nut on hinge pin. When height is correct, tighten locking nut and screw. Front edge of hob height is controlled by adjusting screws, one at each end of top front frame. (Fig. 2).

After hob height has been altered, boiling-plates and grill will have to be realigned by adjustment of the levelling screws on which plates rest (Fig. 3). Plates should be adjusted so that the surfaces are approximately 1/16th inch above hob level.

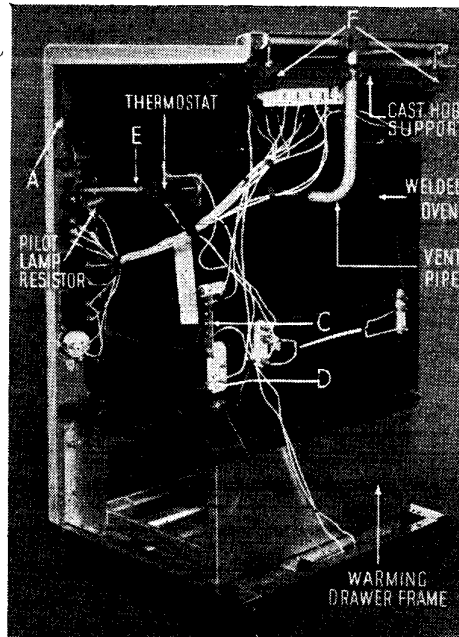

Fig. 6. With side and rear panels removed, all wiring is exposed. Note the oven vent pipe which discharges through small ports in front of splash-plate