

McMICHAEL MODEL 135

TWIN-SPEAKER A.C. SUPERHET

THE McMichael Model 135 A.C. superhet employs four receiving valves and a valve rectifier. The frequency-changer is a triode-pentode, and a separate double-diode is used for second detection and A.V.C. Twin speakers are fitted, and there is a large floodlit tuning scale mounted horizontally, with the controls, under the hinged lid of the cabinet.

CIRCUIT DESCRIPTION

Aerial input by way of fixed series condenser C1, switch S1 and coupling condenser C2 (M.W.), and coupling coil L1 (L.W.) to inductively-coupled band-pass filter. Primary L2, L3 tuned by C23; secondary L4, L5 tuned by C25; image suppression by coil L6.

First valve (V1, Mazda metallised AC/TP) is a triode-pentode operating as frequency-changer with cathode injection. Variable-mu pentode section functions as first detector, while triode forms separate oscillator with anode coils L9, L10, tuned by C27, and reaction coils L7, L8, in common cathode circuit. Tracking by C9 (M.W.) and C10 (L.W.); harmonic suppression by grid resistance R5.

Second valve is a variable-mu H.F. pentode (V2, Cossor metallised MVS-Pen)

operating as intermediate frequency amplifier with tuned-primary tuned-secondary transformer couplings L13, L14 and L15, L16.

Intermediate frequency 128 KC/S.

Small choke coils L11 in V1 pentode anode circuit and L12 in V2 grid circuit prevent parasitic oscillation.

Diode second detector forms part of double-diode valve (V3, Cossor metallised DD4). Second diode, fed from V2 anode by way of coupling condenser C15, provides D.C. potential which is developed across load resistances R12, R13 and fed back through decoupling circuits as G.B. to frequency-changer and I.F. valves, giving automatic volume control. Delay voltage is obtained from voltage drop along V4 cathode resistances R16, R17.

Audio-frequency output from rectifier diode is developed across load resistance R14 and passed by way of coupling condenser C16, manual volume control R20 and grid I.F. stopper R15 to high-efficiency pentode output valve (V4, Mazda AC2/Pen). Fixed tone compensation by condenser C19, and variable tone control by R.C. filter R21, C20. Provision for connection of gramophone

pick-up in grid circuit, across volume control.

H.T. current is supplied by a full-wave rectifying valve (V5, Cossor 442BU). Smoothing by speaker field winding No. 1, L20, and dry electrolytic condensers C21, C22. Speaker field winding No. 2, L21, is connected in series with a ballast resistance R19 across main smoothed H.T. supply.

DISMANTLING THE SET

Removing Chassis.—First of all, note accurately the position of the scale pointer when tuning condensers are at minimum, to enable re-setting correctly when replacing. Pull off the four knobs, supporting the tuning and tone control brackets under top of cabinet if necessary. Now remove the two screws with coin slots which hold the front metal piece engraved "Model 135" etc. There are two thick washers under the plate, which should not be forgotten. Remove the metal piece, and slide out glass and scale. Now remove pointer by pulling the centre boss upwards, off the spindle. There is a paxolin washer under the boss. A screw-driver may be used as a lever to loosen the pointer boss if it is tight.

Remove the four screws holding chassis to bottom of cabinet. Do not allow the whole weight of the chassis to be thrown on the pointer spindle.

Place one hand on each side of the chassis, tilt the back upwards slightly to allow the pointer spindle to leave the hole in the top of cabinet, then withdraw chassis, left-end first.

Behind the front of the cabinet are the two speakers, the resistance R19 (sometimes two in series) and the electrolytic

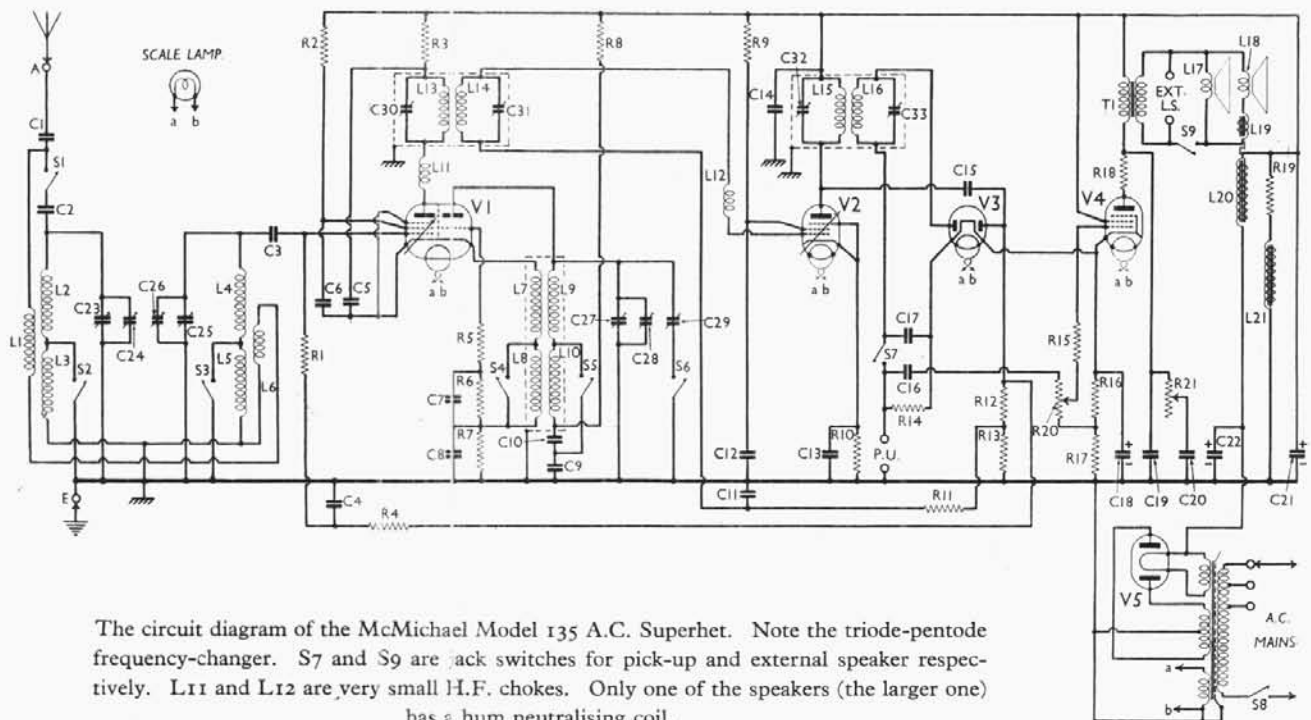

The circuit diagram of the McMichael Model 135 A.C. Superhet. Note the triode-pentode frequency-changer. S7 and S9 are jack switches for pick-up and external speaker respectively. L11 and L12 are very small H.F. chokes. Only one of the speakers (the larger one) has a hum neutralising coil.

condensers C21, C22 in one unit, held by a metal clip.

To remove chassis entirely, unsolder the speaker and scale lamp leads from the terminal strip at the side of chassis. When replacing, the colour code is F, yellow; 1, green; 2, blue; 3, black and brown (scale lamp); 4, red (scale lamp); F, red (speaker). Note that this does not always agree with the coding of the leads from the chassis to the terminal strip.

Removing Speakers.—Each speaker is held by four wood screws, but unless the interconnecting leads, and those from the electrolytic condensers and R19, are unsoldered, it will be necessary to remove the clip holding C21, C22 and the bearer tag, holding R19, before the speakers can be withdrawn, together with the associated components.

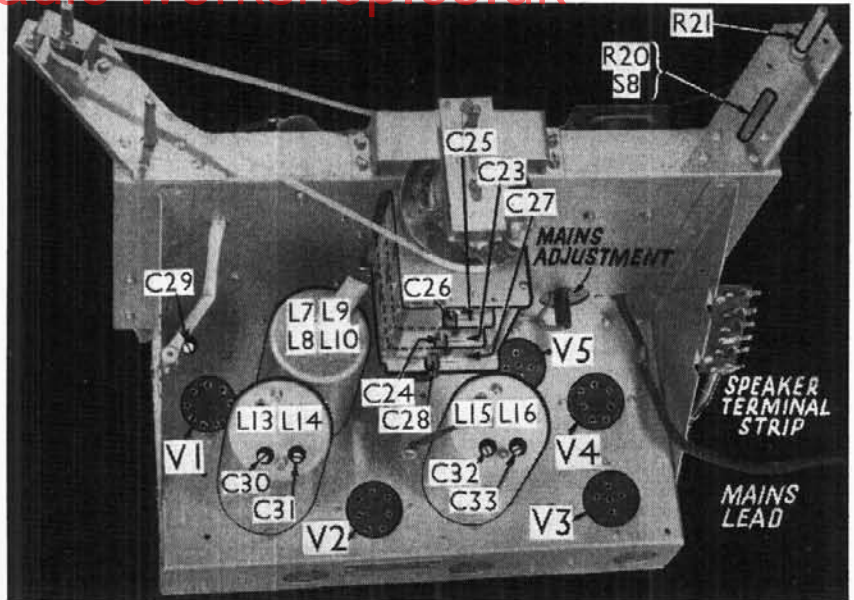

Plan view of the chassis. L7-L10 is the oscillator coil unit, and the other two units are the I.F. transformers. C29 is the oscillator L.W. trimmer. The controls on the left bracket are the tuner and tone control. Note the belt drive of the former.

COMPONENTS AND VALUES

Resistances		Values (ohms)
R1	V1 pent. grid resistance	1,000,000
R2	V1 pent. S.G. H.T. feed	25,000
R3	V1 pent. anode decoupling	10,000
R4	V1 pent. cont. grid decoupling	1,000,000
R5	V1 osc. harmonic suppressor	1,000
R6	V1 triode grid resistance	50,000
R7	V1 fixed G.B. resistance	1,000
R8	V1 triode anode decoupling	60,000
R9	V2 S.G. H.T. feed	60,000
R10	V2 fixed G.B. resistance	175
R11	V2 cont. grid decoupling	500,000
R12	V3 A.V.C. diode load	500,000
R13	V3 A.V.C. diode load	500,000
R14	V3 rectifier diode load	500,000
R15	V4 grid I.F. stopper	100,000
R16	V4 G.B. and A.V.C. circuit	150
R17	delay voltage resistances	500
R18	V4 anode circuit stabiliser	50
R19*	Speaker field (No. 2) ballast	3,000
R20	Manual volume control	500,000
R21	Variable tone control	100,000

* In cabinet between speakers. May consist of two resistors in series.

Condensers		Values (μF)
C1	Aerial series condenser	0.0002
C2	M.W. aerial coupling condenser	0.00001
C3	V1 pent. grid condenser	0.001
C4	V1 pent. cont. grid decoupling	0.1
C5	V1 pent. anode decoupling	0.1
C6	V1 pent. S.G. by-pass	0.5
C7	V1 triode osc. grid condenser	0.0002
C8	V1 cathode by-pass	0.1
C9*	Osc. M.W. tracker, fixed	0.0023
C10*	Osc. L.W. tracker, fixed	0.001258
C11	V2 cont. grid decoupling	0.1
C12	V2 S.G. by-pass	0.1
C13	V2 cathode by-pass	0.1

Condensers (cont.)		Values (μF)
C14	V2 anode decoupling	0.1
C15	V3 A.V.C. diode coupling	0.0001
C16	L.F. coupling to V4	0.005
C17	L.F. by-pass	0.0001
C18	V4 cathode by-pass	25.0
C19	V4 fixed tone compensator	0.002
C20	Tone control condenser	0.03
C21†	H.T. smoothing, electrolytics	8.0
C22†		8.0
C23	Band-pass primary tuning	—
C24	Band-pass primary trimmer	—
C25	Band-pass secondary tuning	—
C26	Band-pass secondary trimmer	—
C27	Oscillator tuning	—
C28	Oscillator main trimmer	—
C29	Oscillator L.W. trimmer	—
C30	1st I.F. trans. pri. tuning	—
C31	1st I.F. trans. sec. tuning	—
C32	2nd I.F. trans. pri. tuning	—
C33	2nd I.F. trans. sec. tuning	—

* Two condensers in parallel.
† Block in cabinet between speakers.

Other Components		Values (ohms)
L1	L.W. aerial coupling coil	12.0
L2	Band-pass primary coils	3.0
L3		12.0
L4	Band-pass secondary coils	3.0
L5		12.0
L6	Image suppressor coil	0.4
L7	Oscillator coupling coils	2.0
L8	Oscillator coupling coils	2.0
L9	Oscillator anode coils	4.0
L10		8.0
L11*	V1 pent. anode anti-parasite choke	Very low
L12	V2 grid anti-parasite choke	Very low
L13	1st I.F. trans.	Pri. 43.0
L14		Sec. 43.0
L15	2nd I.F. trans.	Pri. 43.0
L16		Sec. 43.0
L17	No. 2 speaker speech coil	2.5
L18	No. 1 speaker speech coil	1.5
L19	No. 1 hum neutralising coil	0.1
L20	No. 1 speaker field winding	1,500
L21	No. 2 speaker field winding	7,500
T1	Output transformer	Pri. 450
		Sec. 0.15

* Wound round C5.

(Continued overleaf)

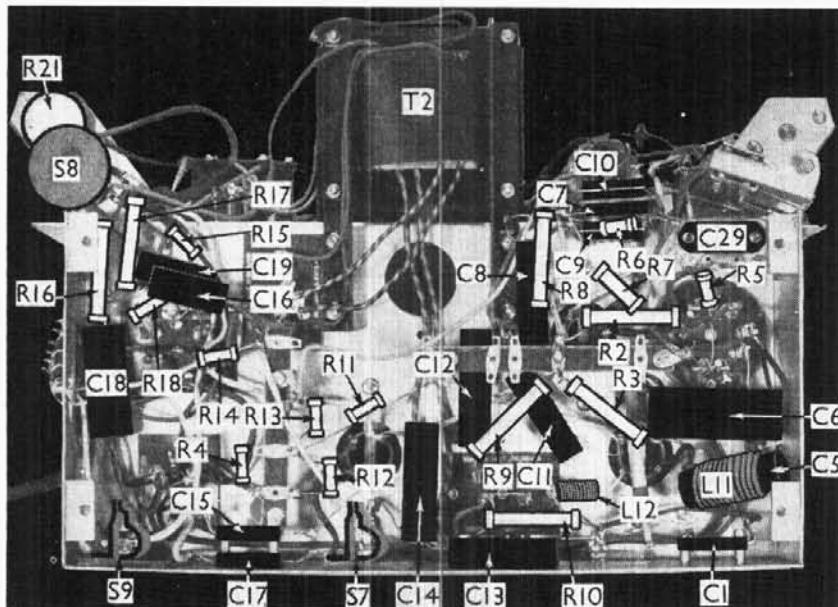

Under-chassis view. L11 and L12 are small H.F. chokes, the former being wound on the tubular case of C5. C9 and C10 each comprise two fixed condensers in parallel. S7 and S9 are the pick-up and external speaker jacks. S8 hides R20, which is ganged with it.

**McMICHAEL MODEL 135
A.C. SUPERHET**
(Continued)

Other Components (cont.)		Values (ohms)	
T ₂	Mains trans. {	Pri. total ..	2250
		Heater sec. ..	0.03
		Rect. heater sec. ..	0.05
		H.T. sec. ..	330
S ₁ -S ₆	Waveband switches, ganged ..	—	
S ₇ †	Gramophone pick-up switch ..	—	
S ₈	Mains switch, ganged R ₂₀ ..	—	
S ₉ †	Internal speaker switch ..	—	

† Operated by special plugs.

VALVE ANALYSIS

The voltage and current readings listed in the table are those given by McMichael for an average chassis working with no signal input.

All voltages were measured on the 1,200 V scale of an Avometer with chassis as negative.

Valve	Anode Volts	Anode Current (mA)	Screen Volts	Screen Current (mA)
V ₁ AC/TP*	180	5.5	190	1.7
V ₂ MVS-Pen	250	8.0	120	2.3
V ₃ DD4	—	—	—	—
V ₄ AC ₂ /Pen	230	20.5	250	6.1
V ₅ 412 BU	350†	—	—	—

* Triode osc. anode 110 V, 1.9 mA.

† Each anode, A.C.

GENERAL NOTES

Switches.—S₁-S₆ are the ganged wave-change switches, seen in our front chassis view, in which all the individual switches are clearly marked. On the M.W. band, S₁, S₂, S₃, S₄, S₅ are closed, and S₆ is open. On the L.W. band, S₁-S₅ are open and S₆ is closed.

S₇ is the pick-up jack, which is closed on radio, and opens when the pick-up is plugged in.

S₈ is the mains Q.M.B. switch, ganged with the volume control, R₂₀.

S₉ is the jack which opens and cuts out the internal speaker when the plug on an external speaker is fully inserted.

Coils.—L₁-L₆ are the band-pass input coils, wound on a paxolin former, and unscreened. They are seen in our front chassis view, and each coil is clearly indicated. L₇-L₁₀ are the oscillator coils,

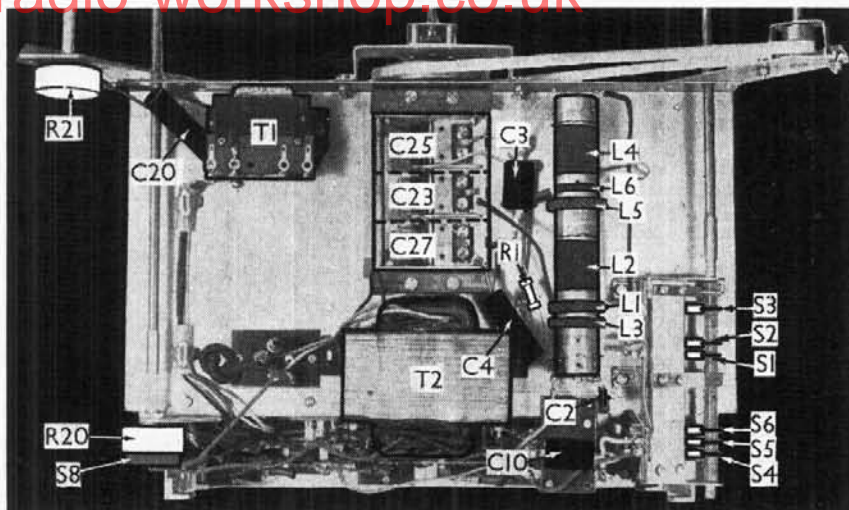

Front chassis view of the receiver. The wave-change switches on the right are clearly indicated. C₂ is a very small condenser, in shape like a small disc.

mounted inside a screen on the chassis deck. The unit is removed by unsoldering the lead to the oscillator tuning condenser emerging from the top, unsoldering the base connections of the coil and undoing the two nuts holding the screen to the chassis. It is not possible to remove the screen separately.

L₁₃, L₁₄ and L₁₅, L₁₆ are the I.F. transformers, with screens similar to that of the oscillator coil.

L₁₁ and L₁₂ are two small single layer chokes, seen in the under-chassis view. L₁₁ is wound in thick insulated wire over C₅, while L₁₂ has a small self-supporting winding.

Scale Lamp.—This is housed in a special tubular holder inside the lid. The holder fits into clips, which also form the lamp connections. By releasing the two knurled clamping screws, the holder may be withdrawn, and the end plugs can be pulled out. The lamp is mounted on one of these. It is an Osram M.E.S. type, rated at 6.2 V, 0.3 A.

Condensers C₉, C₁₀.—These each comprise two fixed condensers in parallel, which are of the correct value within 1 per cent. for correct oscillator tracking.

Condenser C₂₉.—This is the L.W. trimmer for the oscillator anode circuit,

and is reached through a hole in the corner of the chassis, near V₁. It is indicated in our plan chassis view.

External Speaker.—This should be of the low resistance type, with a speech coil of about 2 Ω resistance. When fitted with the special plug provided, it can be used with the internal speakers, or alone. Complete insertion of the plug into S₉ switches off the internal speakers.

Internal Speaker Assembly.—The internal speakers are cross connected, and when removing them individually a careful note should first be made of the connections. Associated with the speakers are C₂₁ and C₂₂, and R₁₉. The condenser unit has a common negative lead (black) and two positives (red). R₁₉ may be a single 3,000 Ω resistance, or two 1,500 Ω types in series.

Valve V₁ Connections.—The triode-pentode has a 9-pin base, and its connections are given in Service Sheet No. 19 (Vol. I), p. 13, col. 2. When removing this valve, as it is not possible to grasp the base with the hand, it may be advisable to insert a screw-driver between the bottom of the base and the chassis, and use it as a lever. Otherwise there may be a risk of loosening the bulb of the valve.

Accumulator Charging Labels

Price **1/9** per
post free book
(6 for 10/-)

DESIGNED to provide all necessary information with minimum of writing, these labels ensure that amounts chargeable to customers' accounts are not overlooked; give easy and rapid means of identifying the battery with the customer; and are sufficiently strong to endure rough handling. A thin top sheet remains fast in book containing details which are duplicated to a thick manilla under sheet. This is separated into two pieces—one fixes to battery giving particulars of job, the other, bearing customer's name and address, goes to alphabetical spiked file or board. Top sheet and both sections of bottom sheets are numbered similarly with large identification number. Books contain 100 labels in duplicate.

Remittance must accompany order. If C.O.D. is desired, fee will be added to all orders under £5 in value

Obtainable from
The Trader Publishing Co., Ltd.
Dorset House, Stamford Street, London, S.E.1