

SERVICE ENGINEER

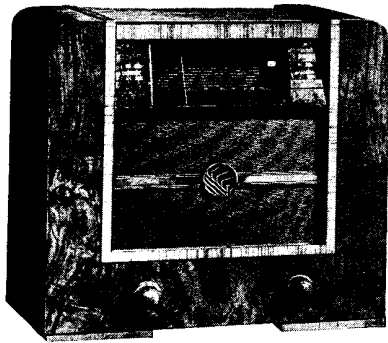

MULLARD M.A.S.4 SUPERHET

CIRCUIT.—A five-valve superhet for operation on A.C. mains and working on short, medium and long wave-lengths.

An inductively and capacitatively coupled band-pass filter couples the aerial to V1, the frequency changer. In the grid lead of this valve is included a small series resistance whose purpose is to prevent any parasitic oscillation which might occur on the short waves.

Coupling to V2, an H.F. pentode, is through an I.F. transformer, tuned to 128 kc. Variable coupling is employed between the windings of this transformer and it is ganged with the tone control.

The output of V2 passes through a second I.F. transformer with fixed coupling to V3, a double diode triode, which is volume controlled by R15. A fixed condenser is connected in series with the slider and brought into circuit by depression of the tuning knob, thus "muting" the receiver.

One diode of V3 is used for demodulation and the other supplies A.V.C. bias to the preceding valves.

I.F. signals are passed through a resistance and capacity stage to the output pentode V4. This is tone controlled in the grid circuit by C42 and R22.

Mains equipment consists of transformer, full-wave rectifier, electrolytic condensers, and a smoothing choke.

Special Notes.—The dial lights are the

Philips type 8042. They are fixed to the dial assembly by spring clips and are easily removable.

Connections for an external speaker are provided and, as these are on the primary of the output transformer, an extension speaker should have its own matching transformer.

The network, consisting of R27, R21, CK1 and CK2, is for balancing out any distortion that might be introduced by the output valve. This is the basis of the "Audioscopic" reproduction.

R32 is inside the connecting cap of V1. **Switching Explanation.**—It will be seen that there are two concentric rings of dots and circles in each switch diagram. The small circles represent contact springs on the stators, and the dots are used where there are no contacts.

The short radial lines between the two concentric rings represent shorting contacts on the rotor. Where there is a solid line joining two or more of these short radial lines, the shorting contacts are actually connected together.

The dotted arcs show that adjacent contacts are shorted together (not permanently, but according to the position of the rotor).

The switches are shown in the open position. They work in a clockwise direction, the order of operation being: Short, medium and long waves, gramophone. With each new position, of course, all the shorting strips move along one set of contacts clockwise.

Removing Chassis.—A fibre board is fitted to the bottom of the cabinet and secured by four small bolts. To get at the underside of the chassis it is only necessary to remove this.

Complete removal of the chassis is as follows:—

Remove the four knobs. These are secured by grub screws, the selectivity

and wave-change knobs having two each. Unclip the pilot lamps and slip the nipples of the wave-change and band width indicator from their slots. Unscrew the adjusting nuts and withdraw the cables. Remove the two nuts on the speaker and free the cables.

Slacken the small screw securing the pointer to the Bowden wire, remove the two slotted nuts securing the scale bracket and free it from the dial assembly.

Unsolder the leads from the chassis to the terminal strip on the speaker, marking them carefully, so that they may be reconnected easily, and unsolder the earthing wire from the chassis to the metallised base plate.

The chassis can then be removed.

ALIGNMENT NOTES

I.F. Circuits.—Connect a modulated oscillator to the grid cap of V1 and an output meter across the external speaker terminals.

Shunt C24 with a 25,000 ohm resistance and turn the selectivity control fully clockwise. Inject a signal of 128 kc., trim C25 for maximum reading on the output meter. Remove the shunt.

Shunt C23 with a 10,000 ohm resistance and a .1 mfd. condenser in series. Trim C22 for maximum reading on the output meter. Remove the shunt.

Shunt C25 with a 25,000 ohm resistance and trim C24 for maximum reading. Remove the shunt.

Shunt C22 with a 10,000 ohm resistance and a .1 mfd. condenser in series. Trim C23 for maximum reading. Remove the shunt.

Medium Waves.—Inject a signal of 208 metres via a dummy aerial to the aerial and earth terminals and tune it in. A template is available from the manufacturers, so that correct adjustment of the tuning condenser may be made. Adjust C17, C14 and C15 for maximum.

If the oscillator coils are badly out of gangle, then for best results use should be

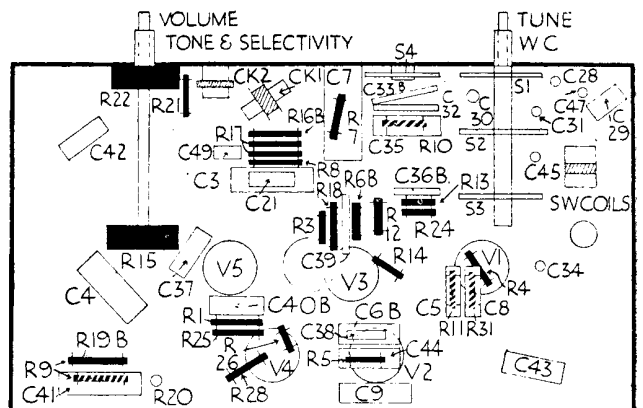
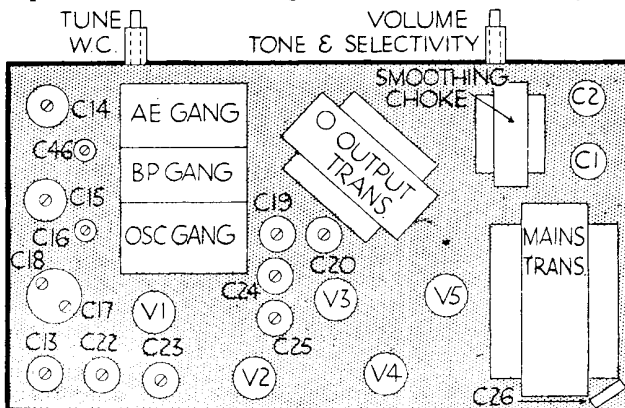

Chassis details of the M.A.S.4 are shown in these diagrams. The letter B following numbers in the under-chassis plan (right) shows the component is the bottom one of an assembly.

MULLARD M.A.S.4 ALL-WAVE SUPERHET (Continued)

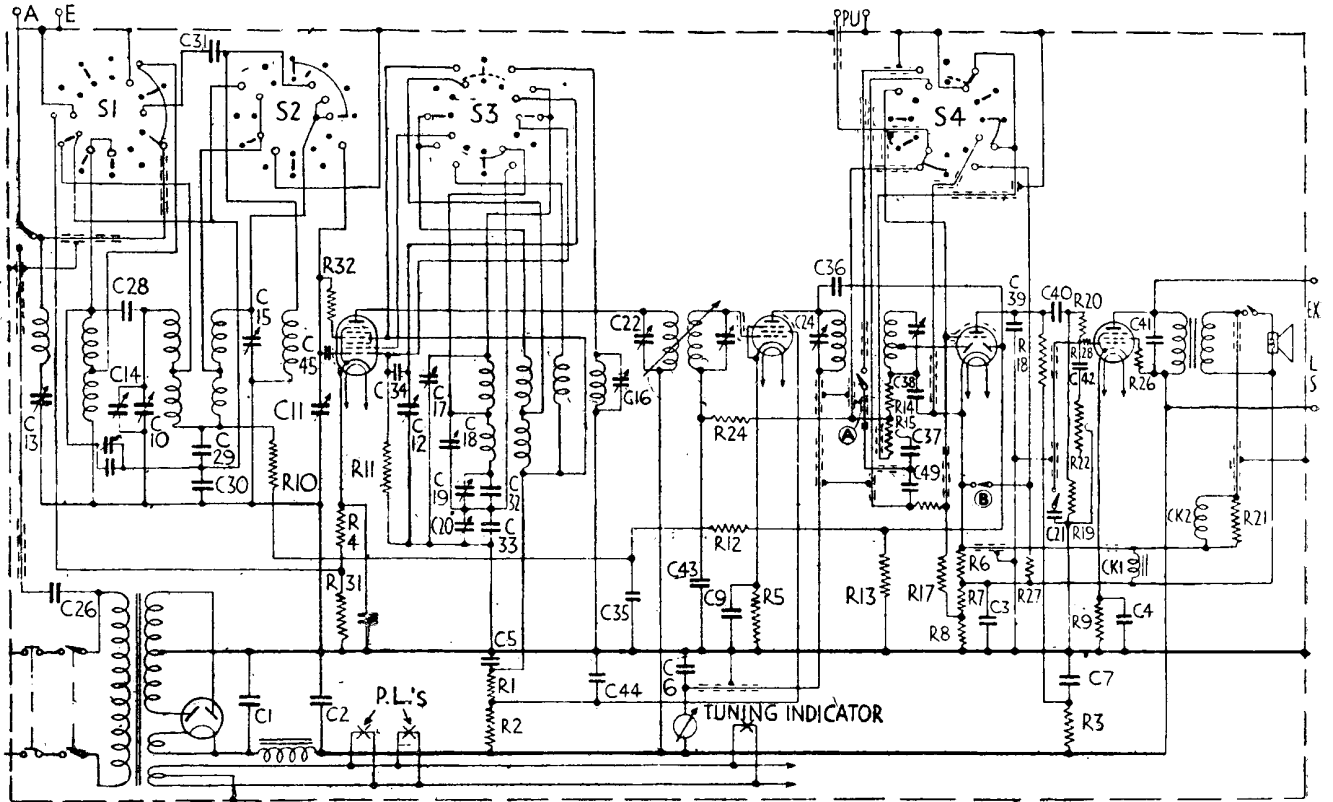

The circuit of the Mullard M.A.S.4 four-valve and rectifier all-wave superhet.

made of an amplifier connected to the anode of V1 via a .00025 mfd. condenser and to the chassis.

The amplifier may be the gramophone side of any reliable receiver, and care should be taken to see that the amplifier grid lead is taken to the anode of V1. The anode lead of V1 is bared and can be reached through a hole in the chassis.

Having satisfactorily connected the amplifier the procedure is as follows: Shunt C22 with a 2,000 ohm resistance and a .1 mfd. condenser in series and inject a strong signal of 545 metres to the aerial and earth terminals. Tune the receiver until it is heard from the amplifier, remove the amplifier and shunt and trim C20 for maximum.

The above should be repeated until best results are obtained.

Long Waves.—Inject and tune in a signal of 760 metres (using template if available). Adjust C18 for maximum response.

Connect up with the amplifier as before and the shunt across C22; inject strong signal of 1,875 metres and tune it in. Then remove the amplifier and shunt and trim C19 for maximum reading.

Short Waves.—Inject and tune in a signal of 17.6 metres (if template is available, the condenser should be adjusted against it) and trim C16 for maximum reading on the output meter.

Aerial Filter.—Switch the receiver to long waves and turn the condenser to maximum. Apply a strong signal of 128 kc. (the intermediate frequency) and trim C13 for minimum on the output meter.

Image Filter.—Inject a signal of 403 metres and tune it in. Leaving the tuning condenser at this setting, inject a strong signal of 300 metres and adjust C46 for minimum.

CONDENSERS

C.	Purpose.	Mfds.
1	H.T. smoothing ..	.32
2	H.T. smoothing ..	.32
3	V3 cathode bias shunt ..	.25
4	V4 cathode bias shunt ..	.25
5	V1 osc. anode and screen decoupling ..	.1
6	V2 anode decoupling ..	.1
7	V3 anode decoupling ..	.5
8	V1 cathode bias shunt ..	.05
9	V2 cathode bias shunt ..	.1
21	Muting ..	.1
26	Mains aerial ..	.0005
28	Band pass coupling ..	.0001
29	V1 A.V.C. decoupling ..	.016
30	Band-pass coupling ..	.025
31	Short-wave coupling ..	.000016
32	Padding ..	.00085
33	Padding ..	.001375
34	V1 oscillator grid ..	.0001
35	V1 A.V.C. decoupling ..	.1
36	A.V.C. diode coupling ..	.00001
37	L.F. coupling ..	.01
38	H.F. by-pass ..	.0001
39	Anode shunt ..	.0004
40	L.F. coupling ..	.02
41	Pentode compensating ..	.004
42	Tone circuit ..	.008
43	V2 A.V.C. decoupling ..	.1
44	V2 screen decoupling ..	.1
45	Osc. regeneration control ..	.000002
47	Image suppressor ..	.00002
49	Speech L.F. coupling ..	.00025

RESISTANCES

R.	Purpose.	Ohms.
1	V1 osc. anode and screen decoupling ..	10,000
3	V3 anode decoupling ..	50,000
4	V1 cathode bias pot. ...	250
5	V2 cathode bias ..	1,250
6	V3 bias network ..	32
7	V3 bias network ..	3,200
8	V3 bias network ..	4,000
9	V4 cathode bias ..	160
10	V1 A.V.C. decoupling ..	.1 meg.
11	V1 osc. grid leak ..	50,000
12	V1 A.V.C. decoupling ..	1 meg.
13	A.V.C. diode load ..	.5 meg.
14	Part demodulator diode load ..	.1 meg.
15	Volume control ..	.5 meg.
16	V3 series grid ..	1.6 meg.
17	V3 grid leak ..	1.6 meg.
18	V3 anode load ..	1 meg.
19	V4 grid leak ..	.8 meg.
20	V4 grid stopper ..	.1 meg.
21	Audioscopic tone filter ..	500
22	Tone control ..	.04 + 2.5
24	V2 A.V.C. decoupling ..	1.6 meg.
25	V2 screen decoupling ..	1,250
26	V4 screen decoupling ..	32
27	Audioscopic tone filter ..	32
28	V4 grid stabiliser ..	1,000
31	V1 cathode bias pot. ...	2,500
32	V1 grid stabiliser ..	50

VALVE READINGS

No signal. Volume maximum. 200 volt A.C. mains.

V.	Type.	Electrode.	Volts.	M.a.
1	All Mullard. FC4 met. (7)	Anode ..	260	2.25
		Screen ..	70	2.
		Osc. anode ..	70	4.9
2	VP4B met. (7)	Anode ..	240	6.4
		Screen ..	150	2.25
3	TDD4 met. (7) ..	Anode ..	70	1.1
		Anode ..	250	3.4
5	DW2 (4)	Screen ..	260	4.
		Filament ..	285	—