

www.radio-workshop.co.uk

B I65

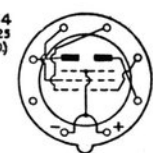
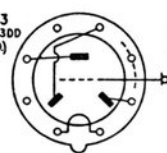
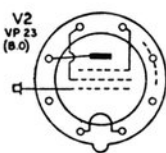
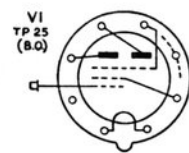
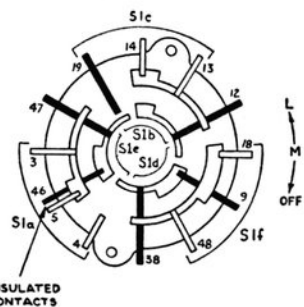
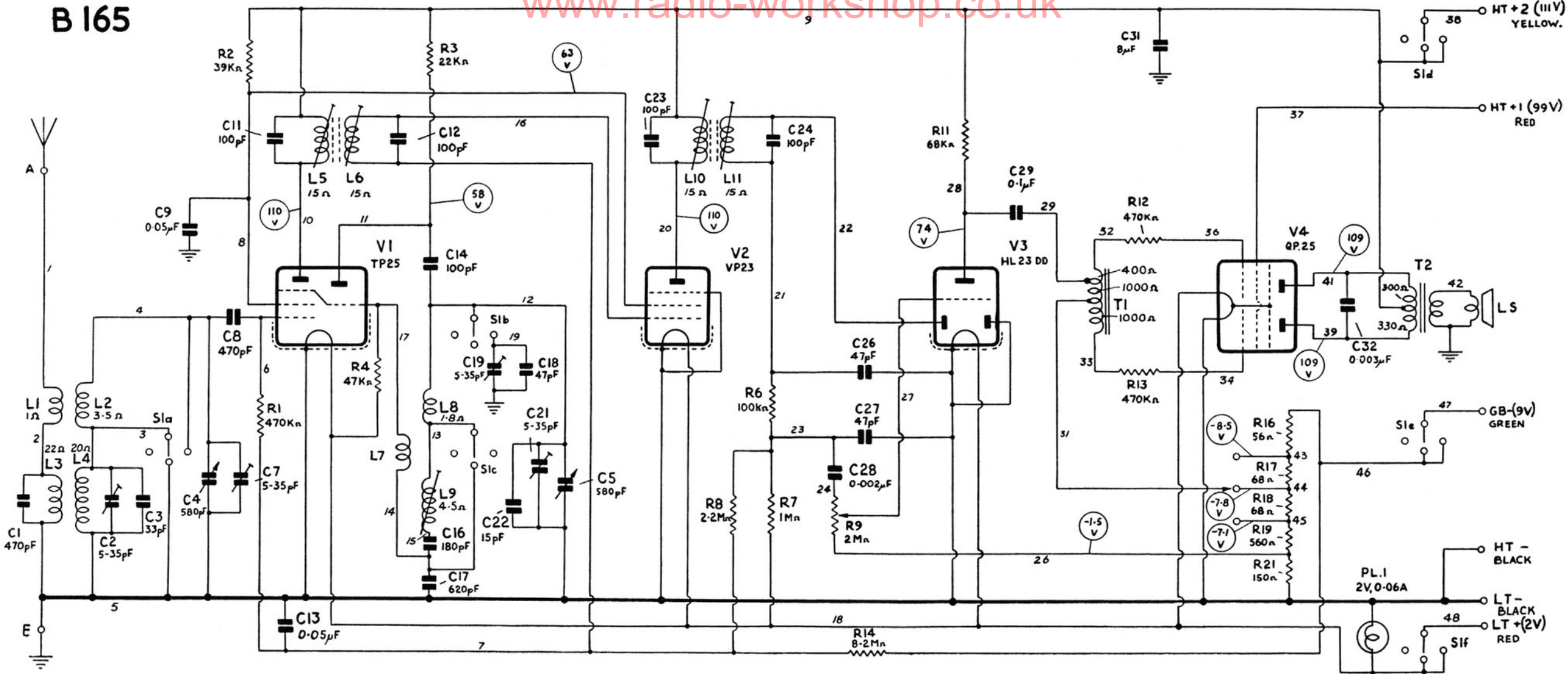

Subject to alteration without notice. Issue B.

A 500 ohm/volt meter was used for taking the voltage readings; the receiver was switched to the medium wave band and operating under "no signal" conditions. In those cases where the resistance of a coil is omitted, the value is less than one ohm. The wave range switch is shown in the medium wave position. The switch wafer is viewed from the rear with the chassis upright, the black contacts and inner rotors being on the hidden side.

Fig. 2.