

CIRCUIT DIAGRAM

www.radio-workshop.co.uk

COMPONENT	VALUE	LOCATION	TEST	
			Fm.	To
L1	16.5	13 M	2	3
L2	4.5	14 M	4	5
L3	12.5	13 M	5	6
L4	4.5	6 F	8	15
L5	12.5	6 E	14	15
L6	1.25	7 E	16	19
L7	6.5	7 F	16	17
L8	50	4 F	19	20
C1A	0.0005 VAR	16-17 M	4	10
C1B	0.0005 VAR	16-17 N	8	10
C2	0.00005	8 B	3	10
C3	0.1	12 O	6	10
C4	8-50 μ mf.	16 M		
C5	0.1	13 P	9	10
C6	3-22 μ mf.	16 N		
C7	0.1	13 P	10	14
C8	0.0005 VAR	2-3 B	10	17
C9	0.0001	6-7 G	8	18
C10	2.25	12 P	10	12
C11	0.0005	4 F	10	19
C12	0.1	14 O	20	21
C13	0.002	4 D	23	31
R1	100,000	10 G	1	2*
R2	2 megohms	7-8 B	6	7
R3	100,000	4-5 C	9	12
R4	20,000	4-5 D	12	14
R5	2 megohms	5 H	11	18
R6	100,000	4 C	12	20
R7	2,000	4 D	12	23
R8	150	4 C	10	22
R9	300	4 C	22	25
R10	700	4 D	24	25
R19	100,000	6 B	22	24*
T1 Prim.	350	3 E	21	22
Sec.	2,000		25	26
T2 Prim.	400	19-20 M	23	31
Sec.	0.3		29	10*
L.S.	Speech Coil		29	10*

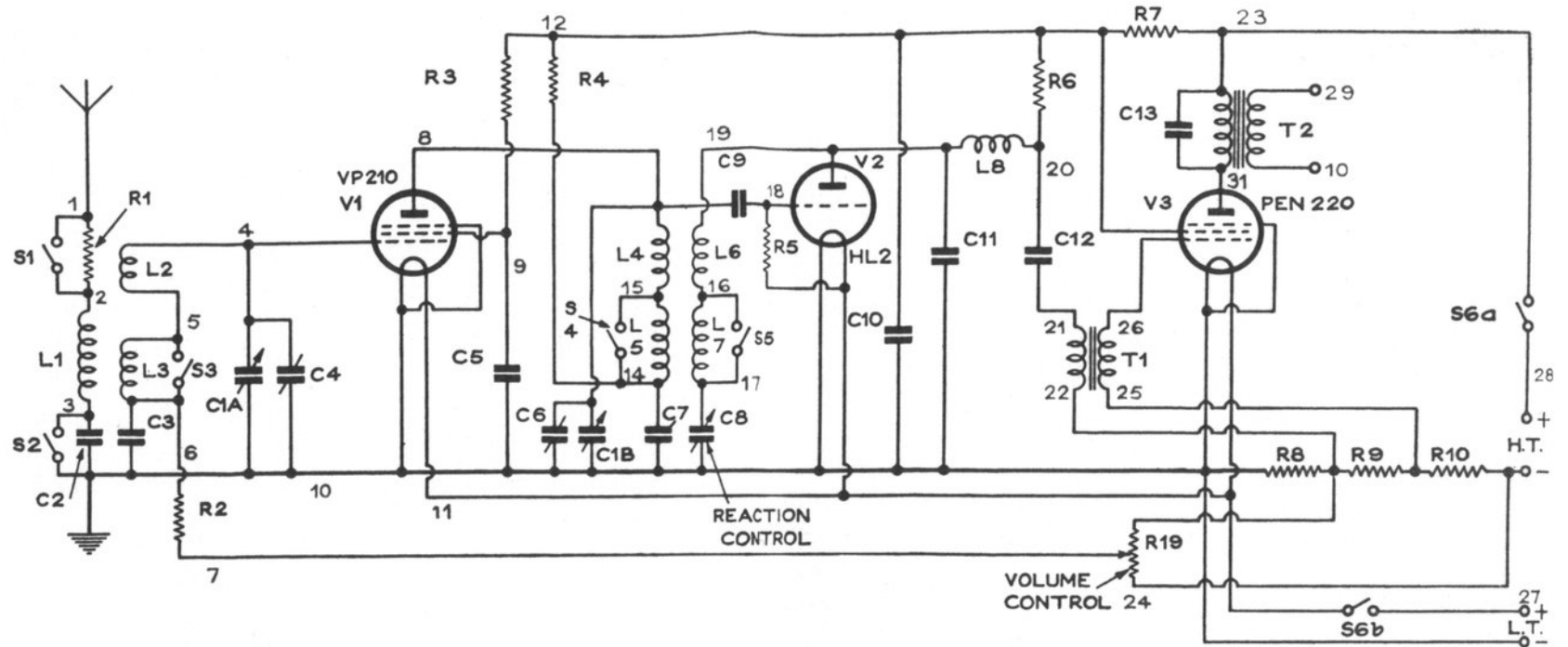

* Disconnect before testing and test directly across component.

NOTE: Condensers should be disconnected from other components when checking capacity; switches should be open for measuring inductances and resistances. Batteries should be disconnected before any components are tested.

All resistances are given in ohms and all condensers in microfarads except where otherwise stated.

D.C. resistance of coils is given in ohms.