

MURPHY SERVICE INSTRUCTIONS

www.radio-workshop.co.uk

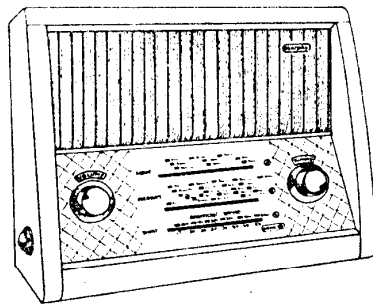

SPECIFICATION

MAINS SUPPLY:	200-250 volts a.c., 50-100 c/s
CONSUMPTION:	42 watts approximately
WAVE BANDS:	Short: 16.8-50.4 metres Medium: 187-540 metres Long: 1000-2000 metres
INTERMEDIATE FREQUENCY:	470 Kc/s
VALVES:	6C9, 6F15 or 6F16, 6LD20, 6P25
SCALE LAMPS:	Two 6.5 volts 0.3 amp. m.e.s.
LOUDSPEAKER:	Type: 8 in. dia., permanent magnet Impedance: 3 ohms
CABINET DIMENSIONS:	19 in. wide, 16 in. high, 8 in. deep
WEIGHT:	18 lb.

Issued by

**MURPHY RADIO LTD
WELWYN GARDEN CITY · HERTS**

PHONE: WELWYN GARDEN 3434

May 1954

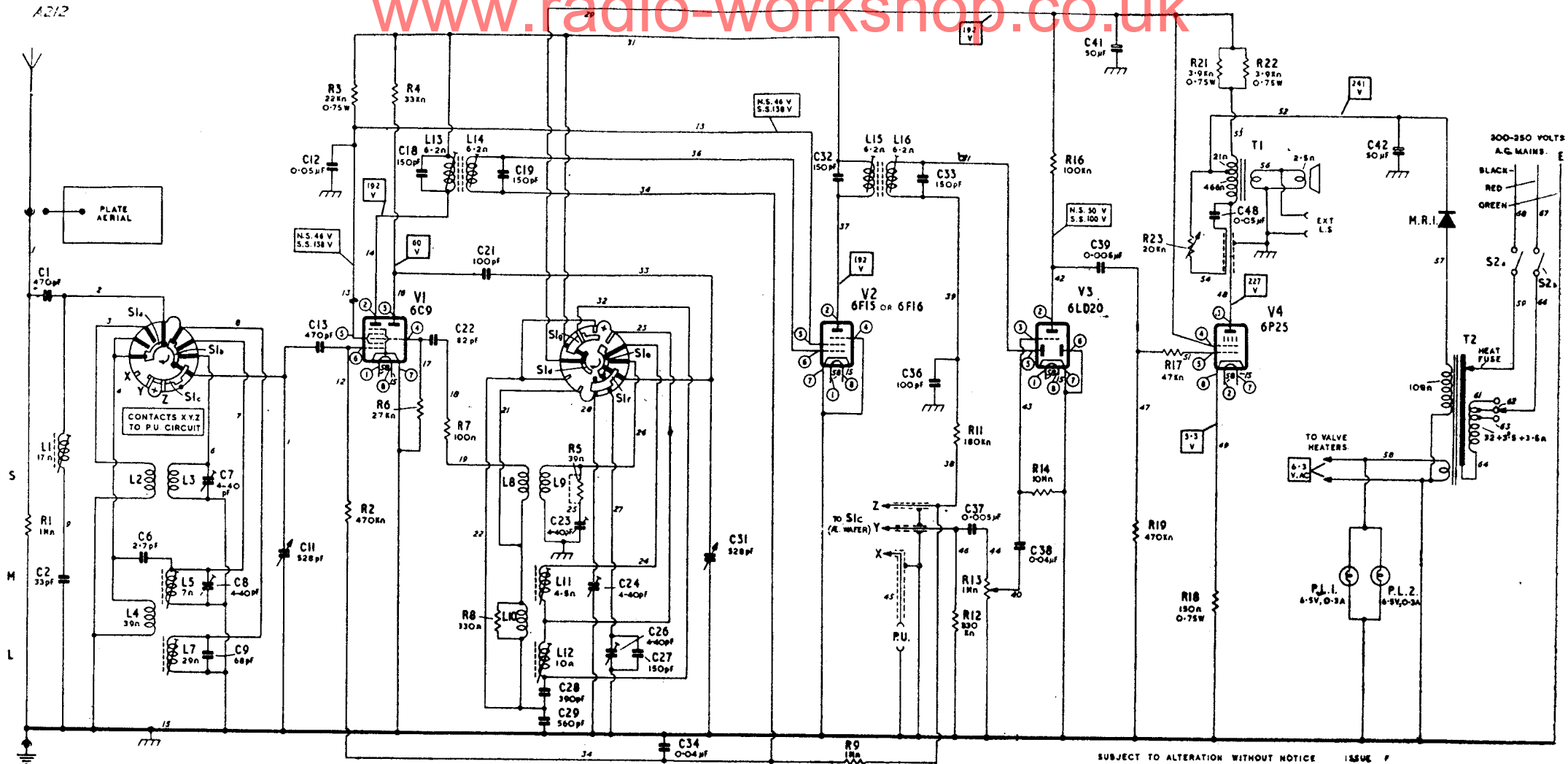

The wave band switch (S1a-S1g) is shown in the long wave position, and is drawn as seen from the rear; rotate clockwise for medium, short and gramophone. The black contacts and inner rotors are on the hidden sides of the wafers and the lugs marked with a cross are the nearer to the chassis. Blank positions and anchoring tags are shown by a spot.

Circuit voltages are shown within rectangles and were measured with a $20\text{K}\Omega/\text{V}$ meter while the receiver was switched to the M band. Two read-

ings are quoted for those points where the voltage differs appreciably from No-Signal (N.S.) to Strong Signal (S.S.) conditions.

Where the resistance of a coil is less than one ohm, the value is omitted. Component terminals and connecting leads are identified by test point (t.p.) numbers which correspond with those appearing on the chassis drawings. The valve pin numbers are shown within small circles.

Squegging. If squegging occurs with some frequency changer valves, R5 must be brought into circuit by cutting the wire link across it.

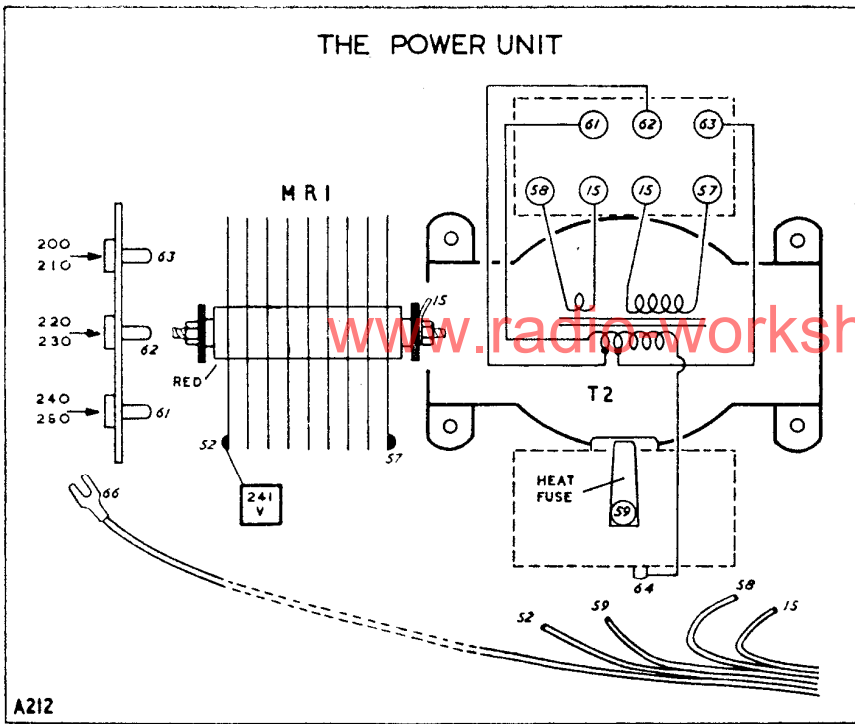

PARTS LIST ABBREVIATIONS

- cer. — ceramic
- p.s.m. — protected silvered mica
- tub. — paper tubular
- m.tub. — metallized paper tubular
- s.tub. — sealed paper tubular
(metal cased)
- elec. — electrolytic
- V d.c. — d.c. voltage rating
- W — wattage rating
- log. — logarithmic law

When removing the chassis, take care not to scratch the tuning scale.
To remove the tuning scale, first remove the loudspeaker and the power unit.

THE CORD DRIVE

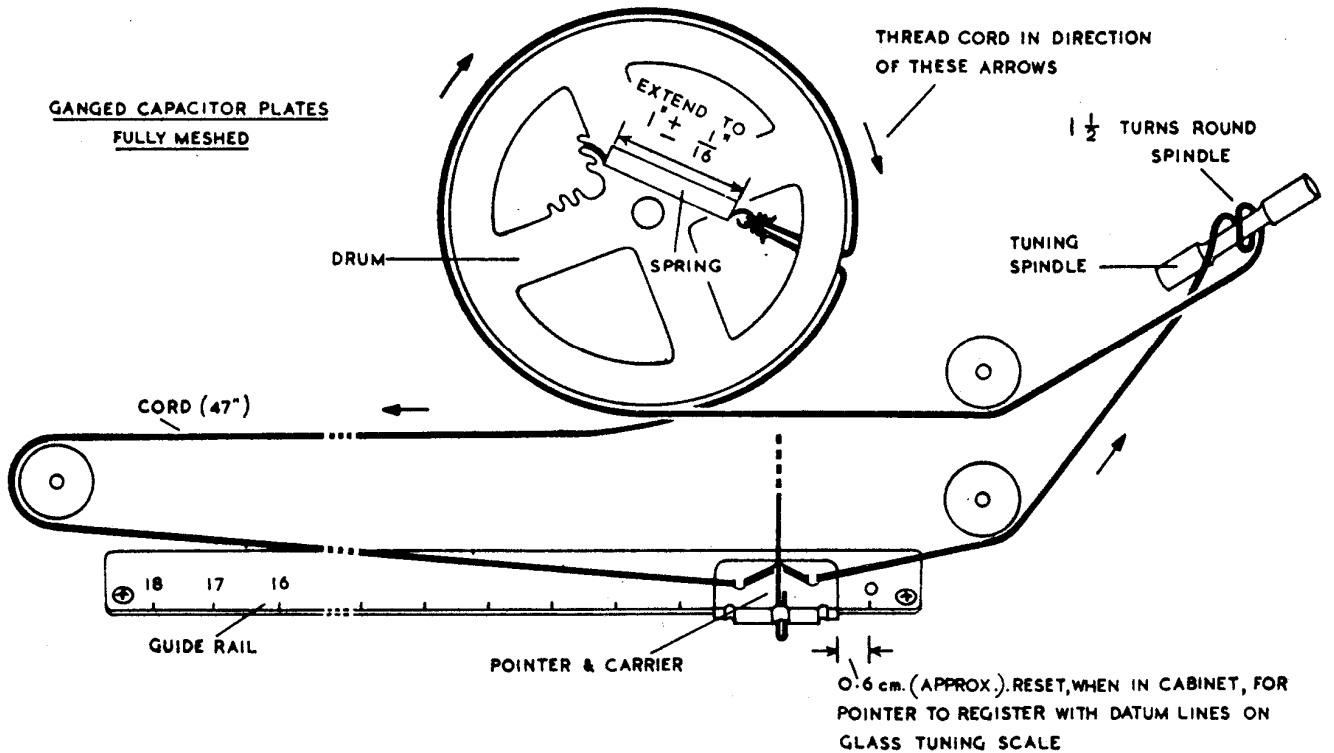

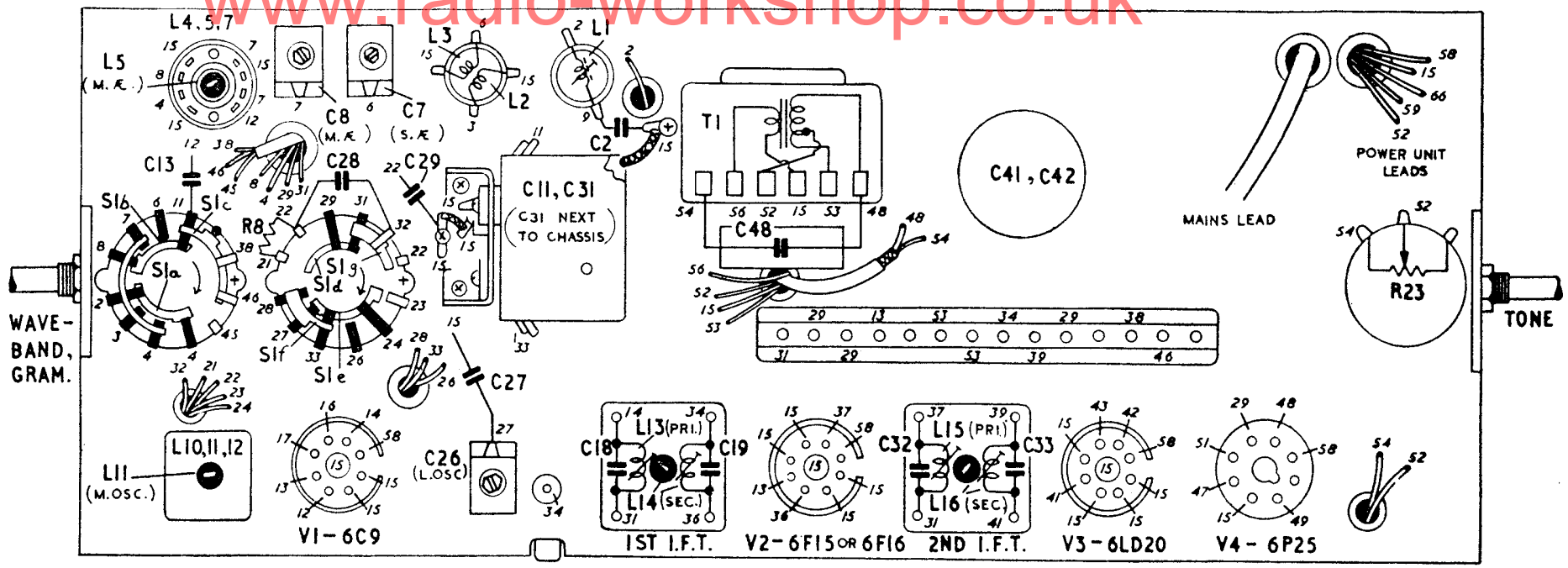

The layout of the front and rear of the chassis

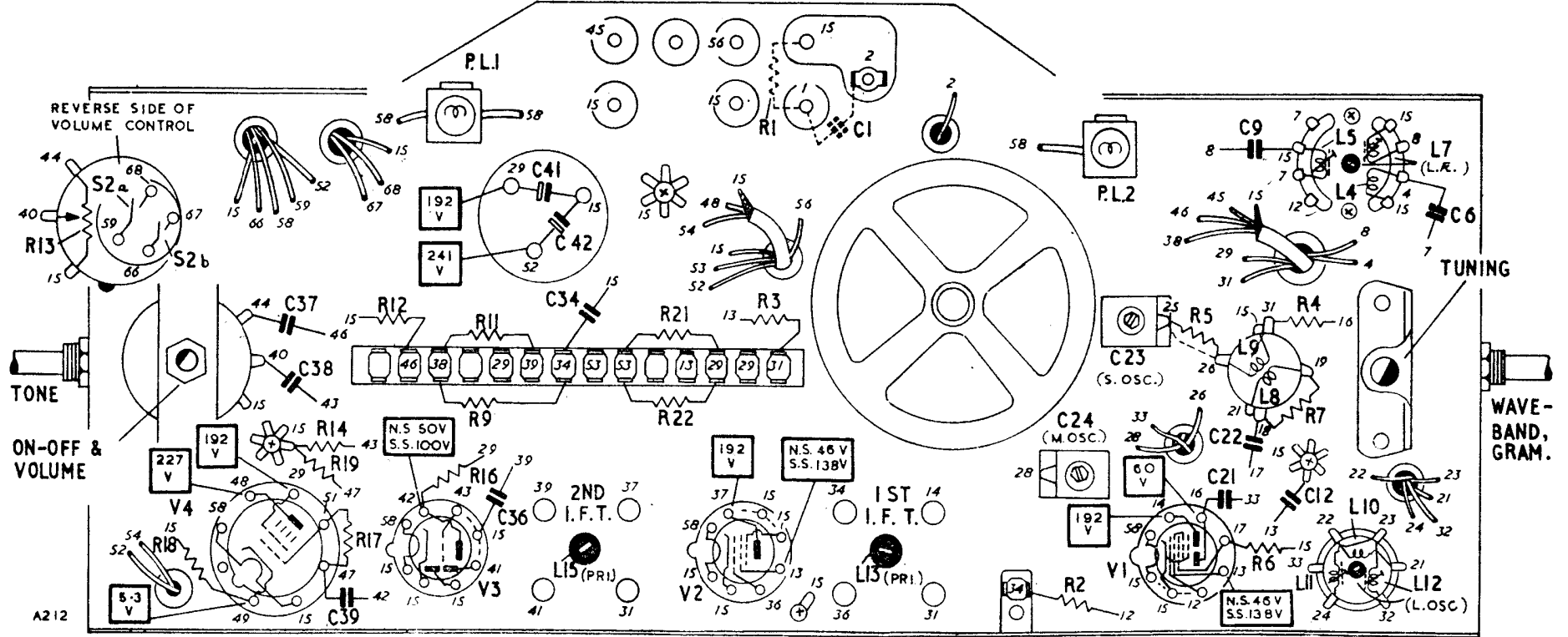

Receiver output. Excepting where otherwise stated, make all adjustments for maximum output with the volume control at maximum. Adjust the signal generator attenuator so that this output does not exceed 500 mW., or 1V across the loudspeaker speech coil.

Trimming tool. A non-metallic tool must be used to adjust the coil cores.

The r.f. coil cores. More than one peak is possible with the r.f. coil cores. In case of difficulty, unscrew the core almost fully and then trim to the first major peak.

The pointer setting. Before aligning the r.f. circuits, make sure that the right-hand edge of the pointer carrier registers with 0.6 cm. on the guide rail when the ganged capacitor plates are just fully meshed (not necessarily against the stop). After the chassis is fitted into the cabinet, the pointer must

be set so that it registers with the datum lines at the right-hand end of the tuning scale when the ganged capacitor plates are fully meshed. The figures in the table refer to the setting of the right-hand edge of the pointer carrier.

Receiver oscillator frequency. On all wave bands, this is higher than the signal frequency.

The scale light reflector. This must be in position during r.f. alignment.

Replacement s.w. coils. The inductance of replacement coils must be adjusted after fitting. Referring to the circuit alignment table, commence at the lower frequency end of the S band and adjust the spacing of the end turns (osc. first). Then adjust the trimmers at the high frequency end of the band. Repeat these adjustments until there is no further improvement and finally seal the windings with wax.

CIRCUIT	NOTES	SIG. GEN. FREQUENCY	SIG. GEN. TERMINATION	CONNECT SIG. GEN. TO	POINTER SETTING	ADJUSTMENTS
2nd i.f.t.	Unscrew sec. core (chassis rear) before starting adjustments	470 Kc/s	Via 0.01 μ F capacitor	V2 signal grid (pin 6)	0.6 cm.	L15 (pri.) at chassis front L16 (sec.) at chassis rear DO NOT RE-ADJUST PRI.
1st i.f.t.	As above. Switch to M band	470 Kc/s	As above	C11 (t.p.11)	0.6 cm.	L13 (pri.) at chassis front L14 (sec.) at chassis rear DO NOT RE-ADJUST PRI.
I.f. rejector	Switch to M band Adjust for minimum output	470 Kc/s	Via dummy aerial	Ae. socket	0.6 cm.	L1 at chassis rear
M	Repeat these adjustments until there is no further improvement	600 Kc/s (500 m.)	As above	As above	2.25 cm.	L11 (osc.) at chassis rear L5 (ae.) at chassis rear
		1363 Kc/s (220 m.)	As above	As above	11.45 cm.	C24 (osc.) at chassis front C8 (ae.) at chassis rear
L	As above	176.5 Kc/s (1700 m.)	As above	As above	4.1 cm.	L12 (osc.) at chassis front L7 (ae.) at chassis front
		300 Kc/s (1000 m.)	As above	As above	12.75 cm.	C26 (osc.) at chassis rear
S	Set C23 to lower capacitance peak. Rock tuning control for maximum sensitivity while adjusting C7	17.8 Mc/s (16.86 m.)	As above	As above	13.9 cm.	C23 (osc.) at chassis front C7 (ae.) at chassis rear
		6.7 Mc/s (44.8 m.)	As above	As above	2.35- 2.65 cm.	No adjustments