

TRADER SERVICE SHEETS RECEIVER SERIES (NUMBER TWELVE)

PORTADYNE B72

BATTERY SUPERHET

ONE of the receivers in the Portadyne 1933-4 range, model B72 is a 5-valve battery-operated superhet, employing seven tuned circuits, diode detection, and a quality Class B output stage. A band-pass input filter with a special image-rejecting coil minimises second channel interference, and another important point is that automatic G.B. compensation is provided, thus ensuring that the reproduction remains good throughout the useful life of the H.T. battery.

CIRCUIT DESCRIPTION

Aerial input by way of series condenser **C1**, switch **S2**, and special coils **L1**, **L4**, to inductively-coupled band-pass filter. Primary **L2**, **L3** tuned by **C13**; secondary **L5**, **L6** tuned by **C15**. **L1** is a special stopper coil switched in an L.W., and **L4** is a small winding which minimises second channel interference. Local-distant switching by means of switch **S1** and resistance **R1** which shunts aerial circuit for local reception. First valve (**V1**, Mullard plain **PM12M**) functions as combined oscillator and first detector. Oscillator tuning coils **L11**, **L12**, tuned by **C20**; cathode coupling by means of coils **L7**, **L8** and **L9**, **L10** in filament circuit. One variable-mu S.G. intermediate frequency amplifier (**V2**, Mazda metallised **S215VM**) with tuned-primary tuned-secondary transformer couplings **L13**, **L14** and **L15**, **L16**. I.F. 112 KC/S. Gain controlled by variable potentiometer **R12** which varies G.B. applied. Diode second detector forming part of double diode triode (**V3**, Mazda metallised **L2/DD**) with diode anodes in parallel. Triode section functions as first L.F. amplifier and is R.C. coupled to driver valve (**V4**, Mullard metallised **PM2DX**). Precision for gramophone pick-up in grid circuit. Driver feeds Class B output stage

(**V5**, Mazda **PD220A**) by way of special transformer **T1**. Tone compensation by condenser **C12**. **V5** is coupled to speaker by special input transformer **T2**.

DISMANTLING THE SET

Removing Chassis.—Remove the three main knobs (vol. control, tuning and wavechange), held by two grub screws each. Remove 1-hole fixing nut from Q.M.B. switch (**S8**) at left-hand side of cabinet. Unsolder the two wires from the push-pull switch (**S1**) at bottom of cabinet. Loosen clip holding loud-speaker lead, and free the lead.

Chassis is held by four bolts with large washers. Remove these, when chassis can be withdrawn to extent of speaker lead. This will be sufficient for most tests.

To remove chassis entirely, the three speaker leads must be unsoldered from speaker terminal panel. When replacing, these must be re-connected to the top three tags, in the order black, red, black, starting from the top. The two bottom tags are left free.

The battery shelf can be slid out to give more room for these operations.

Removing Speaker.—This is held to its sub-baffle by four lock-nutted bolts, but it may be preferable to remove it with the sub-baffle, as the bolts are liable to turn. The sub-baffle is held by the two ornamental screws, lock-nutted, and four wood-screws. When replacing, note that the speaker transformer should be on the right of the chassis.

COMPONENTS & VALUES

Resistances		Values (Ohms)
R1	Aerial shunt (loc.-dist.)	35
R2	V1 grid resistance	250,000
R3	D.C. by-pass across C19	10,000
R4	Diode load	1,000,000
R5	V3 anode resistance	30,000
R6	H.F. stopper	50,000
R7	V3 grid resistance	500,000
R8	V4 grid resistance	1,000,000
R9	V4 grid H.F. stopper	250,000
R10	T1 secondary shunts	10,000
R11		10,000
R12	Radio volume control	5,000
R13	Volume control shunt	1,200

Condensers		Values (μF)
C1	Aerial series condenser	0.0005
C2	V1 grid condenser	Small
C3	V1 S.G. by-pass	0.1
C4	H.T. blocking (osc.)	0.1
C5	V2 S.G. by-pass	0.1
C6	Diode reservoir	0.0002
C7	V3 anode by-pass	0.002
C8	V3 grid condenser	0.005
C9	V4 grid condenser	0.005
C10	H.F. by-pass	0.0001
C11	H.T. supply reservoir (electrolytic)	4.0
C12	V5 anodes by-pass	0.002
C13	Band-pass pri. tuning	—
C14	Band-pass pri. trimmer, pre-set	—
C15	Band-pass sec. tuning	—
C16	Band-pass sec. trimmer, pre-set	—

(Continued overleaf.)

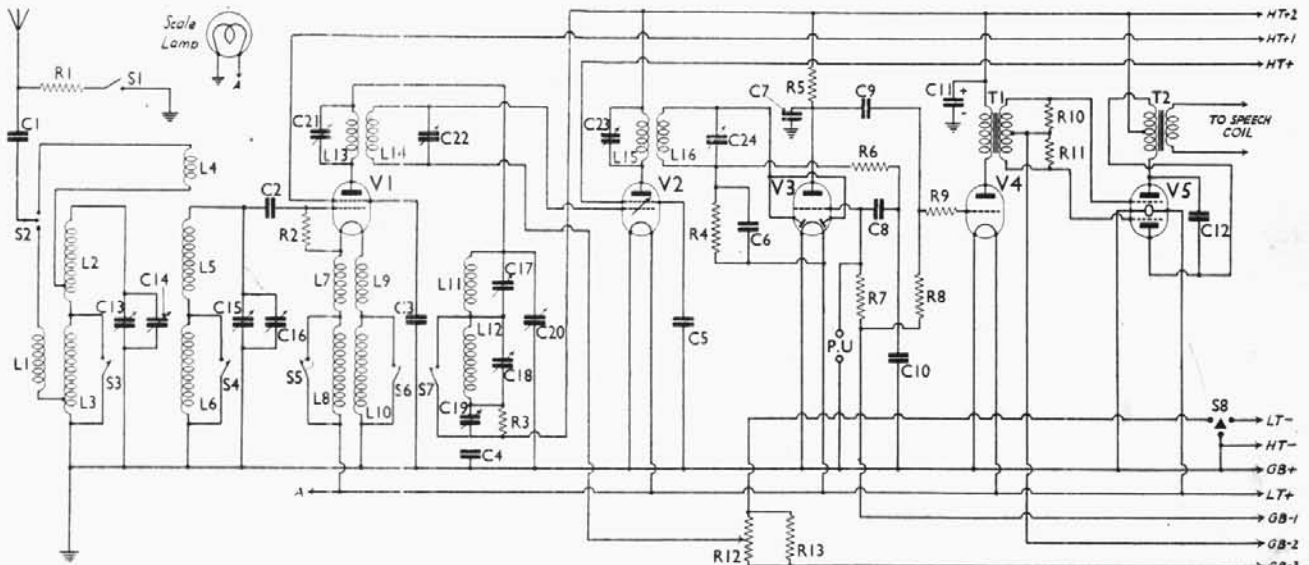

Fig. 1.—The circuit of the Portadyne B72 battery superhet. The top of C4 should be joined to the bottom of C19.

PORTADYNE B.72 (contd.)

www.radio-workshop.co.uk

various leads were plugged into the sockets recommended by the makers. These are as follow:—HT—, HT—; HT+, +40 V; HT+1, +60 V; HT+2, +120 V; GB+, GB+; GB—1, —3V; GB—2, —4.5 V; GB—3, —13.5 V. All

GENERAL NOTES

In our under-chassis view we have removed the two cross strips (2 screws each) and also the flat shield over the 1st I.F. transformer, **L13, L14** (3 screws). This, of course, will not always be necessary.

Condensers (contd.)		Values (μF)
C17	Oscillator M.W. trimmer, pre-set	—
C18	Oscillator L.W. trimmer, pre-set	—
C19	Osc. padding condenser, pre-set	0.003
C20	Oscillator tuning	—
C21	1st I.F. trans. pri. tuning	—
C22	1st I.F. trans. sec. tuning	—
C23	2nd I.F. trans. pri. tuning	—
C24	2nd I.F. trans. sec. tuning	—

Other Components		Values (Ohms)
L1	Stopper coil (L.W.)	35.0
L2	Band-pass pri. coils	6.8
L3		26.0
L4	Image rejector (M.W.)	0.15
L5		6.8
L6	Band-pass sec. coils	26.0
L7		0.15
L8	Oscillator coupling coils	0.15
L9		0.15
L10	Oscillator tuning coils	3.9
L11		26.0
L12	1st I.F. trans. former	85.0
L13		85.0
L14	2nd I.F. trans. former	85.0
L15		85.0
L16	Driver trans. former	200.0
T1		26.0
T2	Speaker input transformer	480.0
S1	Local-distant switch	—
S2-S7	Wave-band switches (ganged)	—
S8	Filament switch	—

A sketch showing the wave-change switch assembly, as it would be seen from the underside of the chassis, with the plate which covers it removed.

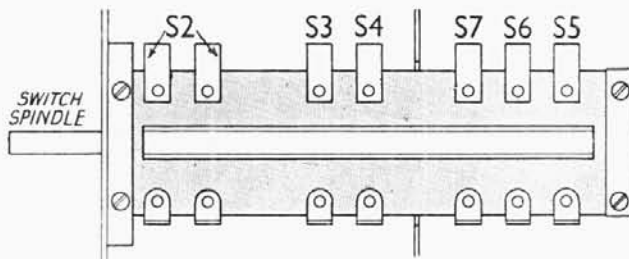

readings were taken with no input to the aerial socket, and with the volume control at maximum. Anode and screen voltages were measured on the 1,200 V scale of an Avometer, with the negative side returned to chassis, and the anode and screen currents of **V1** and **V2** were measured with a meter inserted in the low H.F. potential ends of the circuits to prevent instability.

The total H.T. consumption of the receiver with the output stage idle was approximately 9.5 mA.

Valve	Anode Volts	Anode Curr. (mA)	Screen Volts	Screen Curr. (mA)
V1. PM12M	133	0.9	95	0.3
V2. S215VM	133	1.1	45	0.2
V3. L2DD	95†	1.1†	—	—
V4. PM2DX	130	2.5	—	—
V5. PD220A	133*	1.6*	—	—

*Approx., each anode. †Triode section.

Switches.—Of the switches, **S1** is a push-pull type, underneath the main controls on the front, which switches **R1** in or out of circuit for local-distant

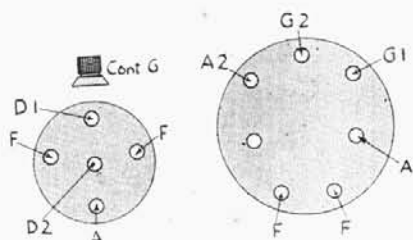

Under-chassis connections of the **V3** and **V5** valve-holders.

VALVE ANALYSIS

The voltage and current readings given in the table (Col. 2) were taken with a brand new 120 V H.T. battery, which had a terminal voltage of 135 V, and the

reception. **S8** is the 3-point Q.M.B. on-off switch, fitted to the side of the cabinet.

S2-S7 are ganged, and form the wave-band switches. Of these, **S3-S7** are all

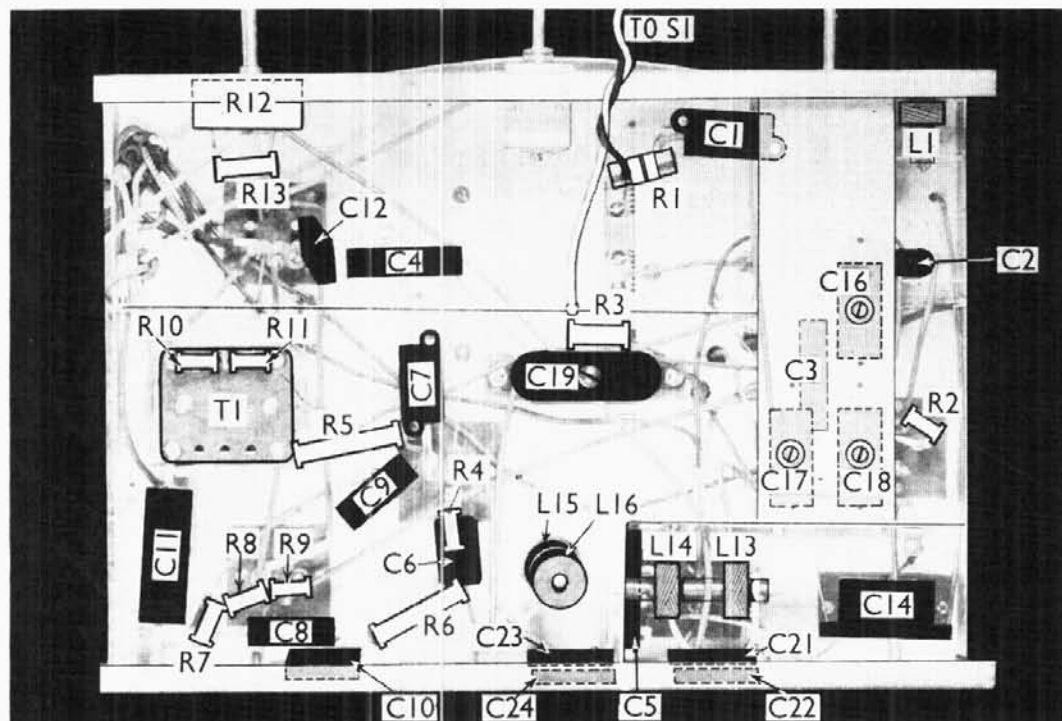

Fig. 2. — Under-chassis view. The cross-bars and the screen over the bottom right-hand corner have been removed. Beneath the plate carrying **C16, C17, C18** is the switch assembly, shown separately on this page. **C3** is below this assembly. **C2** is formed by two wires twisted together. **C21, C22, C23** and **C24** are pre-set condensers fixed to the back of the chassis.

closed on the M.W. band, and open on the L.W. band.

S2 consists of two sets of contacts forming a single-pole changeover switch. On the M.W. band the contacts nearest the spindle and knob end of the switch are closed, and the second set of contacts is open. On the L.W. band, the first set (nearest knob) is open, and the second closed.

To get at the switches it may be necessary to remove the plate carrying condensers **C16**, **C17**, **C18**, and the associated wiring. We give a sketch of the waveband switches, as seen when this plate is removed.

Oscillator Coil.—This is mounted on the top of the chassis, and is screened by a cylindrical "pot," held by a single nut. The coil itself comprises **L7-L12** inclusive. The windings are, however, rather complicated, and in case of trouble it may be advisable to obtain a replacement coil. Make sure that the wires from the coil passing through holes in the chassis have not chafed sufficiently to cut the insulation.

Image Rejector, L4.—This is coupled to **L5** and is held by an adjustable mounting arm which is sealed in position at the works. Be careful not to bend this arm, and so alter the coupling.

Condenser C2.—This consists of a few turns of wire, double-wound, and waxed.

Condenser C11.—This is a $4 \mu\text{F}$ dry electrolytic type, having a working voltage of 200 V D.C. The polarity is indicated in the circuit diagram.

Condenser C14.—This is the aerial trimmer, operated by the screw at one corner of the upper surface of the chassis.

Trimmers C16, C17, C18.—These can

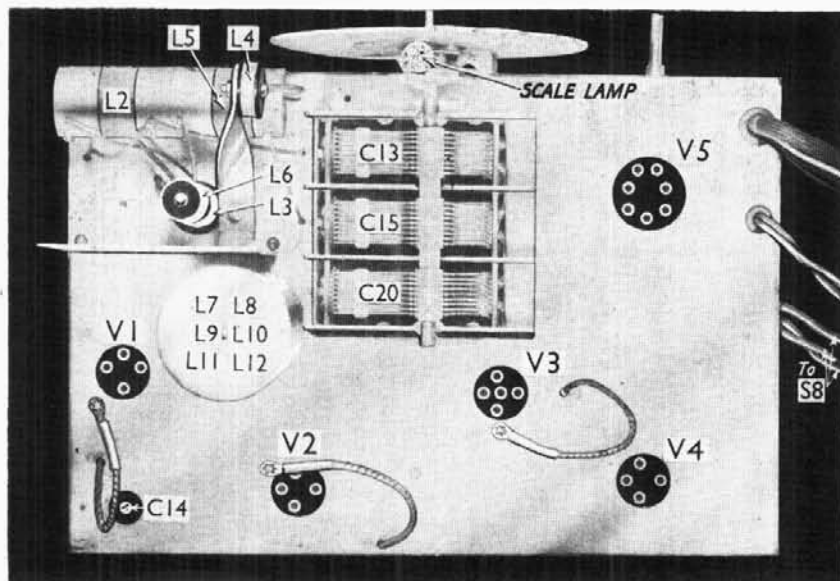

Fig. 3.—Plan view of the chassis of the Portadyne B72 battery superhet. The inductances **L7-L12** form the oscillator coil and are inside the screening can. The band-pass coils are not shielded except by a small vertical screen. Note the image rejector **L4**.

be reached without removing the chassis, by detaching the card glued over two apertures in the base of the cabinet.

Alternative Valves.—**V2** in our sample was a Mazda **S215 VM**, but a Mullard **PM12M** may be fitted. **V5** was a Mazda **PD220A**, but an Osram **B21** may be used as an alternative.

Scale Lamp.—This is an Osram M.E.S. type, rated at 2.5 V, 0.15 A.

Batteries.—The batteries supplied are a C.A.V. type SGM mass-type 2V L.T.

cell, and a Pertrix "Ultra Capacity" combined H.T. and G.B. battery, 120 V + 13.5 V.

Loud-speaker.—This is a Celestion PPM9-L. It has an input transformer **T2**, with a centre tapped primary connected to the three upper tags. The lower two are connected to the secondary, and are thus in parallel with the speech coil. This has a resistance of 2.3 O. An external low-resistance speaker could be connected to these tags.