

www.radio-workshop.co.uk

"TRADER" SERVICE SHEET

1085

PYE P45 & P46

Covering also Autoradiogram P45RG

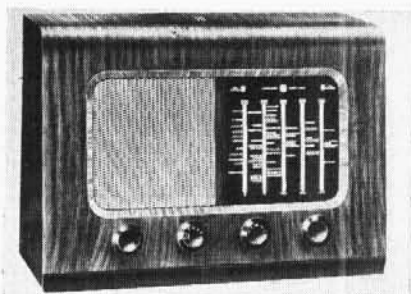

The appearance of the Pye P45. This model has a wooden cabinet, but is otherwise the same as P46.

EQUIPPED with three band-spread S.W. ranges, the Pye P46 is a 3-valve (plus rectifier) 5-band superhet designed to operate from A.C. mains only of 200-250 V, 40-100 c/s. It employs a double-wound mains transformer, and the chassis may be earthed directly. The waveband ranges are approximately 184-550 m, 1,000-2,000 m and the 16 m, 31 m and 49 m S.W. bands. An identical chassis is employed in the P45, but it is housed in a wooden cabinet. A basically similar chassis is employed also in the

P45RG, but the I.F. and audio frequency circuits are considerably modified to permit the use of the I.F. amplifier as a pick-up pre-amplifier. All three models are fully covered in this *Service Sheet*, but our sample receiver was a P46.

Release dates and original prices: P45, September 1950, £19 5s 3d; P45RG, August 1951, £45 11s 11d; P46, August 1952, £15 8s 11d. Purchase tax extra.

CIRCUIT DESCRIPTION

On the two normal tuning bands the aerial is coupled by L1 (M.W.) and C2 (L.W.) to single-tuned circuits L3, C36 (M.W.) and L2, C36 (L.W.), which precede triode hexode valve (V1, Mullard ECH42) operating as frequency-changer with internal coupling. S13 closes on these bands to connect the aerial section of the gang C36. S11 also closes on both bands to shunt C3 across the aerial input and C4 across the tuning circuit. S12 closes on L.W. to shunt C5 across L2 as an additional trimmer.

On the three band-spread ranges S13 opens and S12 closes to connect the fixed capacitor C5 in place of C36, the aerial circuit then being fixed-tuned to the centre of each band. S11 also opens on the band-spread ranges and the aerial is coupled by C3, C4 to single-tuned circuits L4, C5 (49 m band), L5, C5 (31 m band) and L6, C5 (16 m band).

On the two normal tuning bands, triode oscillator coils L8 (M.W.) and L7 (L.W.) are connected in a Colpitts circuit with C12, C37 and

C13, C14, and are tuned by C38 via S35, which closes on these bands.

For band-spread operation, S35 opens and S36 closes. The band-spread oscillator coils L9 (49 m band), L10 (31 m band) and L11 (16 m band) are arranged in a Colpitts circuit with C11, C17, C18 and C38. Tuning is performed by C38 via band-spreading capacitors C17, C18.

Second valve (V2, Mullard EBF80) is a double diode R.F. pentode, its pentode section operating as intermediate frequency amplifier, with tuned transformer couplings C8, L12, L13, C9 and C21, L14, L15, C22.

Intermediate frequency 470 kc/s.

One diode section of V2 operates as signal detector, and the audio frequency component in its rectified output is developed across load resistor R12 and passed via C30 and volume control R15 to control grid of pentode output valve (V3, Mullard EL41).

Second diode of V2 is fed via C20 from V2 pentode anode, and the resulting D.C. potential, developed across load resistor R10, is fed back via step-down potential divider R8, R9 to V1 and V2, giving automatic gain control.

Six-position tone control switching (four on radio, two on gram) S39-S41 gives bass cut via C25, and varies the frequency response of the negative feedback circuit C28, C29, C26, C27, R13 and R14, between V3 anode and grid circuits. Provision is made for the connection of a gramophone pick-up across the volume control circuit via S38, which together with radio muting switch S37 forms part of the tone control switching. Radio/gram change-over switching is performed automatically by the operation of the tone switch control. Provision is made for the con-

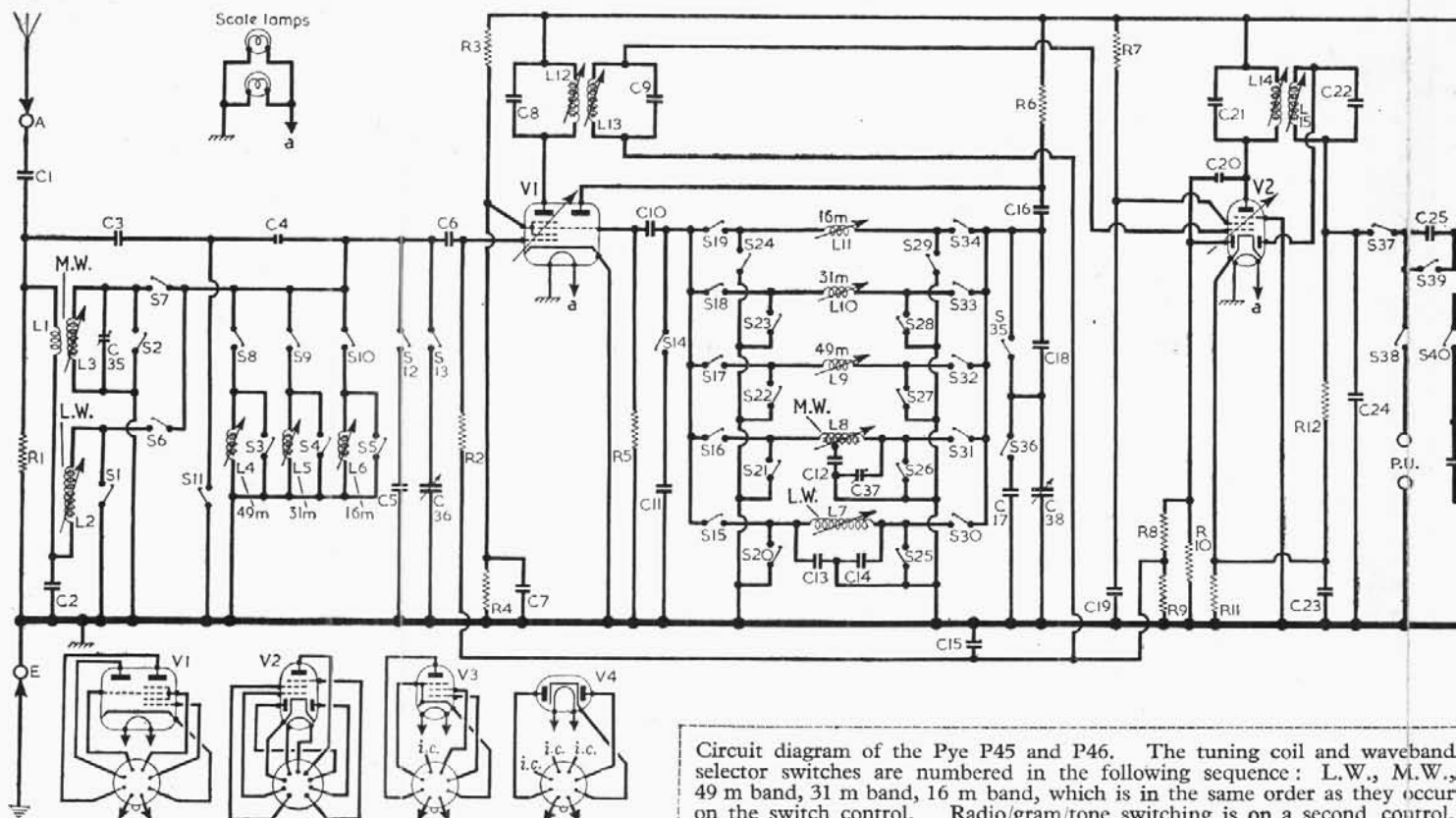

Circuit diagram of the Pye P45 and P46. The tuning coil and waveband selector switches are numbered in the following sequence: L.W., M.W., 49 m band, 31 m band, 16 m band, which is in the same order as they occur on the switch control. Radio/gram/tone switching is on a second control.

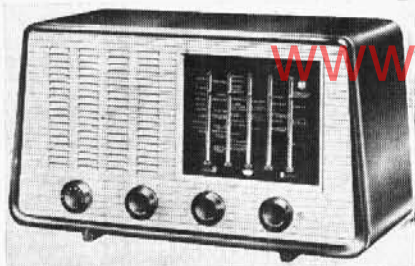

Photograph showing the appearance of the Pye P46, which is housed in a plastic cabinet.

nection of a low impedance external speaker across T1 secondary winding.

In the gram model the tone switch control has three radio and three gram positions. The audio frequency component in the three radio positions is developed across R12, as in the table model, and is passed via C44 and volume control R15 to the output valve. In the three gramophone positions of the tone switch control, the cathode, control grid and screen grid of V2 are used as a triode pick-up pre-amplifier, the pick-up being connected to V2 control grid via L13. The amplified output, developed across R23, is passed via C43 to the volume control, switches S45, S49 closing on gram and opening on radio, and switches S44, S46, S48, S50 opening on gram and closing on radio.

Tone control switches S51, S52, which are ganged to the radio/gram switches S44-S50, shunt C46 and R24, giving bass boost and top cut respectively when they close.

H.T. current in all three models is supplied by I.H.C. full-wave rectifying valve (V4, Mullard EZ40). Smoothing by R18 and electrolytic capacitors C32, C33 and C34. The heaters of all the valves, including V4, are fed from winding a on mains transformer T2.

COMPONENT VALUES AND LOCATIONS

RESISTORS			Values	Locations	CAPACITORS (continued)			Values	Locations
R1	Aerial shunt	...	22kΩ	G4	C8	1st I.F. trans. tun. {	100pF	B1	
R2	V1 C.G.	...	1MΩ	F4	C9		100pF	B1	
R3	V1 S.G. pot.	...	22kΩ	F4	C10		100pF	F3	
R4	divider	...	33kΩ	F4	C11	Bandspread trimmer	180pF	F3	
R5	V1 osc. C.G.	...	47kΩ	F3	C12	M.W. osc. trim.	510pF	G3	
R6	Osc. anode feed	...	10kΩ	F3	C13	J.W. osc. trimmers {	150pF	F3	
R7	V2 S.G. feed	...	33kΩ	F3	C14		150pF	G4	
R8	A.G.C. pot. divider {	...	2.2MΩ	E4	C15	A.G.C. decoupling	0.02μF	E4	
R9		...	2.2MΩ	F4	C16	Osc. anode coupling	100pF	F4	
R10	A.G.C. diode load	...	1MΩ	E4	C17	Bandspread capacitors {	270pF	G3	
R11	V2 G.B.	...	680Ω	E4	C18		150pF	G3	
R12	Signal diode load	...	470kΩ	F4	C19	V2 S.G. decoupling	0.1μF	F4	
R13	Parts tone control {	...	220kΩ	E4	C20	A.G.C. coupling	10pF	E4	
R14		...	4.7kΩ	E3	C21	2nd I.F. trans. tun. {	100pF	B2	
R15	Volume control	...	1MΩ	E3	C22		100pF	B2	
R16	V3 C.G. stopper	...	*2.2kΩ	E4	C23	V2 cath. by-pass	0.1μF	F4	
R17	V3 G.B.	...	180Ω	F4	C24	I.F. by-pass	470pF	E4	
R18	H.T. smoothing	...	†1kΩ	D4	C25	Part tone control ... {	0.005μF	D3	
R19	Parts P.U. tone correction {	...	100kΩ	—	C26		0.002μF	E3	
R20	A.G.C. decoupling	...	1MΩ	—	C27	15pF	E3		
R21	H.T. decoupling	...	470kΩ	—	C28	0.05μF	E4		
R22	V2 S.G. load	...	10kΩ	—	C29	0.01μF	E4		
R23	V2 S.G. load	...	22kΩ	—	C30	A.F. coupling	0.01μF	D3	
R24	Part tone control	...	15kΩ	—	C31*	V3 cath. by-pass	25μF	F4	
					C32*	24μF	C2		
					C33*	24μF	C2		
					C34*	24μF	C2		
					C35†	M.W. aerial trim.	50pF	G4	
					C36†	Aerial tuning	528pF	A2	
					C37†	M.W. osc. trim.	50pF	G3	
					C38†	Oscillator tuning	528pF	A1	
					C39	P.U. coupling	0.02μF	—	
					C40	P.U. tone corrector	0.02μF	—	
					C41*	V2 cath. by-pass	50μF	—	
					C42	V2 S.G. decoupl.	0.002μF	—	
					C43	A.F. coupling ... {	0.1μF	—	
					C44		0.1μF	—	
					C45*	H.T. decoupling	36μF	—	
					C46	Parts tone control {	500pF	—	
					C47		0.02μF	—	
					C48	Tone corrector	0.002μF	—	

* Changed to 47kΩ on gram. model.
 † Centre tapped.

CAPACITORS			Values	Locations
C1	Aerial coupling	...	470pF	G4
C2	L.W. aerial coup.	...	0.0024μF	G4
C3	Bandspread aerial	...	100pF	G4
C4	coupling	...	5.6pF	G4
C5	Bandspread tuner	...	100pF	G4
C6	V1 C.G.	...	100pF	F4
C7	V1 S.G. decoupl.	...	0.1μF	F4

(Continued next column)

* Electrolytic. † Variable. ‡ Pre-set.
 § "Swing" value, min. to max.

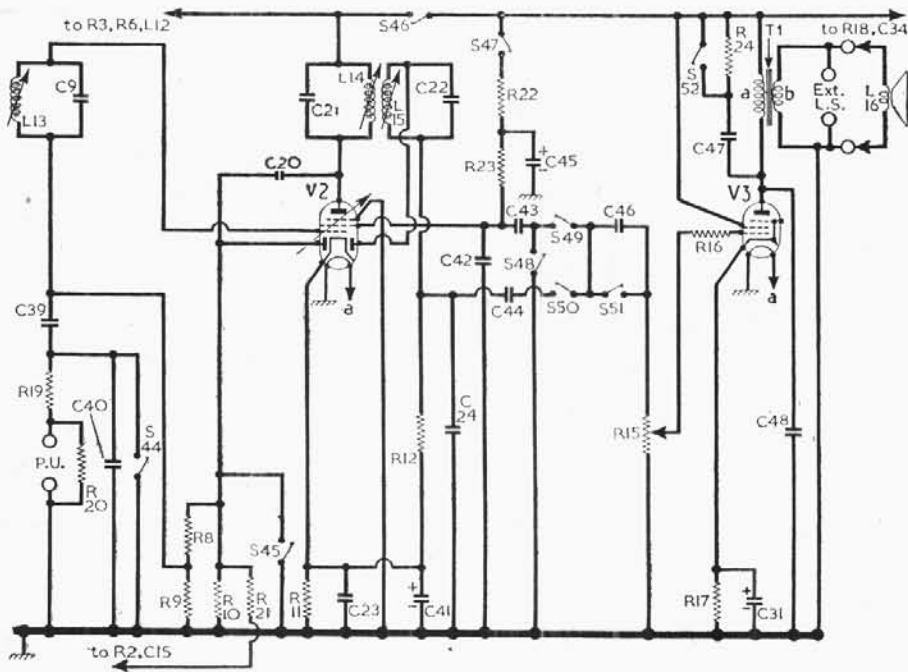
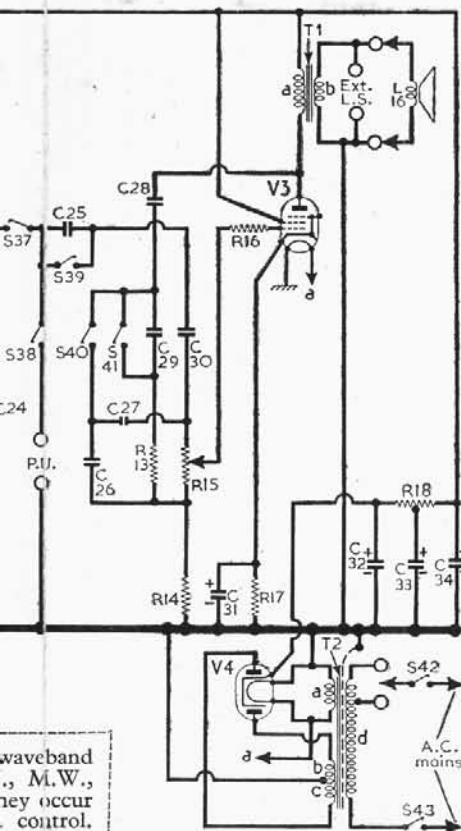
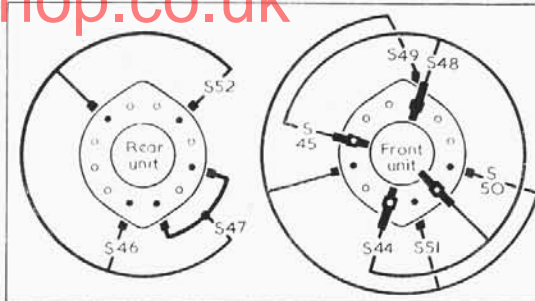

Diagram of the I.F. and output stages of the P45RG, which are quite different from those in the P45, P46. V2 is used as a gramophone pre-amplifier, the pick-up being connected in its control grid circuit. Most of the switches in the diagram are concerned with the radio/gram switching, only S51, S52 being used for tone control.

OTHER COMPONENTS		Approx. Values (ohms)	Locations	
L1	M.W. aerial coup.	30.0	G4	
L2	L.W. aerial tuning	50.0	G4	
L3	M.W. aerial tuning	2.3	G4	
L4	Band-spread aerial tuning coils ...	—	G4	
L5		—	G4	
L6		—	F4	
L7		—	G3	
L8	L.W. osc. tuning	3.5	G3	
L9	M.W. osc. tuning...	1.5	G3	
L10	Band-spread osc. tuning coils ...	—	F4	
L11		—	F5	
L12	1st I.F. trans. { Pri.	12.2	B1	
L13		Sec.	12.2	B1
L14	2nd I.F. trans. { Pri.	12.2	B2	
L15		Sec.	12.2	B2
L16	Speech coil	2.3	—	
T1	O.P. trans. { a ...	500.0	C2	
		b ...	—	—
		c ...	285.0	C2
		d, total	305.0	C2
S1-S36	Waveband switches	38.0	G4	
S37-S41	Tone/gram switches	—	D3	
S42-S43		Mains sw, g'd tone sw.	—	D3
S44-S52	Tone/gram switches		—	—

Diagrams of the tone-control and radio/gram change-over switch units as they are in the P45RG, derived from the diagrams shown in the makers' service manual. They are drawn as they would be seen when viewed from the rear of an inverted chassis, front and rear units being identified. Below them is the associated table.



GENERAL NOTES

Switches.—S1-S36 are the waveband switches, ganged in two rotary units beneath the chassis. These are indicated in our underside illustration of the chassis, where they are identified by the numbers 1 and 2 in diamond surrounds. The arrows there indicate the direction in which the units are viewed in the diagrams in col. 4, where they are shown in detail.

The table beside them gives the switch positions for the five control settings, starting from the fully anti-clockwise position of the control knob. A dash indicates open, and C, closed.

S37-S41 in the P45 and P46 are the tone control and radio/gram change-over switches, ganged in a single seven-position unit beneath the chassis. The unit is indicated in our underside illustration of the chassis, and it is shown in detail in the diagram in col. 3, where it is drawn as seen from the rear of an inverted chassis.

Ganged with this unit is the Q.M.B. double-pole mains switch unit S42, S43, which opens in the "off" position of the control. The action of the S37-S41 switches is shown in the accompanying table, starting from the fully anti-clockwise position of the control knob. A dash indicates open, and C, closed.

S44-S52 are the tone control switches in the P45RG. These are ganged in two rotary units in the same position as we show S37-S41 in the P45,P46 chassis. S42, S43 still being operated by the same spindle. This tone control unit still has six positions and "off," but they are now divided into three radio and three gram positions.

A detailed diagram of the two switch units, drawn as seen from the rear of an inverted chassis, shown at head of col. 3, is derived from information given in the makers' service manual, as our sample receiver was a P46. The table associated with it gives the switch positions for the seven control settings (including "off"), starting from the fully anti-clockwise position of the control knob. A dash indicates open, and C, closed.

Scale Lamps.—These are two lamps with M.E.S. bases and large spherical bulbs painted white, rated at 6.5 V, 0.3 A.

Capacitors C8, C9, C21, C22.—These are the

Switch	Radio			Gram		
	Off	F	B	M	F	M
S44 ...		C	C	C	—	—
S45 ...	C	—	—	—	C	C
S46 ...	—	C	C	C	C	C
S47 ...	—	C	C	C	C	C
S48 ...	—	—	—	—	C	C
S49 ...	C	—	—	—	C	C
S50 ...	—	C	C	C	—	—
S51 ...	C	C	—	C	—	C
S52 ...	—	—	—	C	—	C

fixed tuning capacitors for the I.F. transformers. They are contained within the screening cans, but they may not be visible even when the cans are removed, as they form an integral part of the transformer construction.

External Speaker.—Two sockets are provided at the rear of the chassis for the connection of a low impedance (about 2.4Ω) external speaker. Beside them is another pair of sockets for the internal speaker, which may be muted by removing one of the plugs.

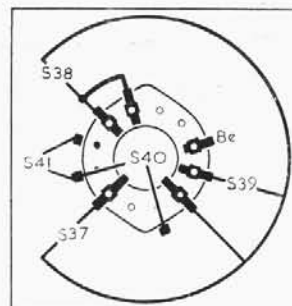

Diagram of the tone control and radio/gram change-over switch unit as it is in the P46. It is drawn as seen from the rear of an inverted chassis. Below is the associated table.

Switch	Radio					Gram	
	Off	F	B	M	S	F	M
S37 ...	C	C	C	C	C	—	—
S38 ...	—	—	—	—	—	C	C
S39 ...	—	C	—	C	—	C	C
S40 ...	—	—	—	C	C	—	—
S41 ...	C	—	C	—	C	—	—

CIRCUIT ALIGNMENT

I.F. Stages.—Remove chassis from cabinet and stand it on the bench so that adjustments above and below chassis are accessible. Connect signal generator output, via an 0.1 μF capacitor in the "live" lead, to control grid (pin 6) of V1 and chassis. Switch receiver to L.W. and tune to high wavelength end of band. Feed in a 470 kc/s

VALVE ANALYSIS

Valve voltages and currents given in the table below are those quoted by the manufacturers. They were measured with the receiver operating from 212 V A.C. mains, the voltage adjustment being set to the 200-220 V tapping. The receiver was switched to L.W. and the gang turned to maximum, but there was no signal input.

Voltage readings were measured with a Model 7 Avometer, chassis being the negative connection except where otherwise indicated.

Valve	Anode		Screen		Cath.
	V	mA	V	mA	
V1 ECH42	220 Oscillator 150	2.5 6.0	75	3.5	—
V2 EBF80	220	4.8	130	2.2	4.4
V3 EL41	205	29.0	220	5.0	6.3
V4 EZ40	510*	—	—	—	275.0†

* A.C. reading, anode to anode.
† Cathode current 53.0 mA.

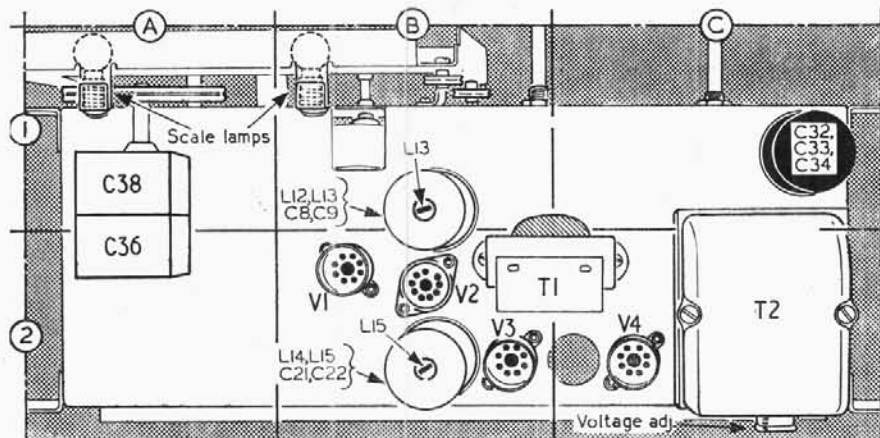

Plan view of the chassis of the P46. In the P45RG V3 occupies the vacant hole stamped in the chassis near V4. The scale assembly is a different shape, too, and is disposed symmetrically on the chassis.

www.radio-workshop.co.uk

Underside view of the chassis of the P46. Detailed diagrams of the waveband switch units, indicated here by numbers 1 and 2 in diamond surrounds, appear in col. 4 below. A diagram of the tone control switch unit appears near the foot of col. 3. At the head of col. 3 are the diagrams of the two tone control switch units as used in the P45RG.

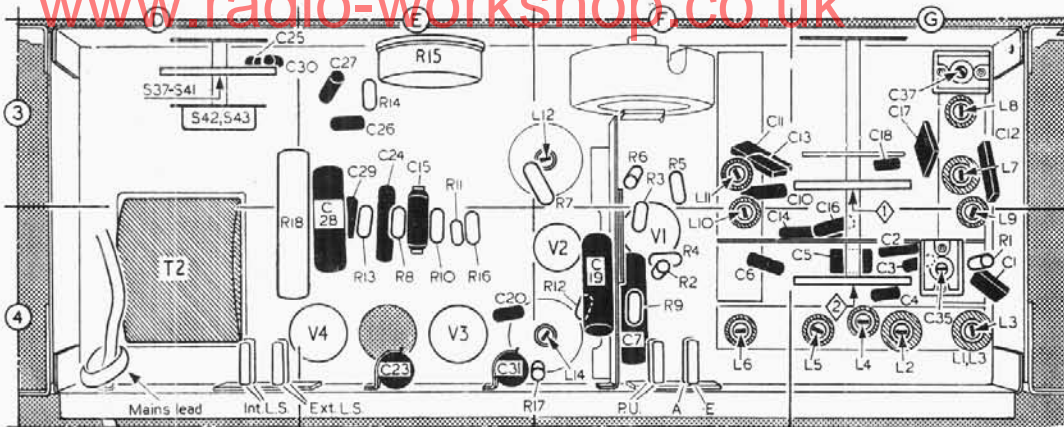

(638.3 m) signal and adjust the cores of **L15** (location reference B2), **L14** (F4), **L13** (B1) and **L12** (F3) for maximum output. Repeat these adjustments until no further improvement results.

R.F. and Oscillator Stages.—As the tuning scale remains fixed to the cabinet when the chassis is withdrawn, reference must be made, during the following alignment, to the substitute tuning scale printed on the left-hand side of the scale backing plate (viewed from front). Readings on this scale are taken against the lower horizontal edge of the cursor carriage. Check that with the gang at maximum capacitance the substitute scale reading is 100. Transfer signal generator leads, via a standard dummy aerial, to **A** and **E** sockets.

In the gram model, the substitute scale is calibrated 0-50, and when carrying out the following alignment the receiver must be tuned

Sketches showing the drive cord systems in the P45 and P46 (left) and the P45RG (right). They are drawn as seen when viewed from the rear with the gang at maximum capacitance. The P45RG drawing is reproduced from the makers' service manual.

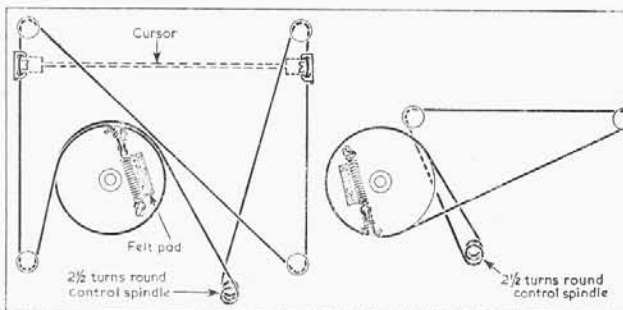

Waveband Switch Diagrams and Table

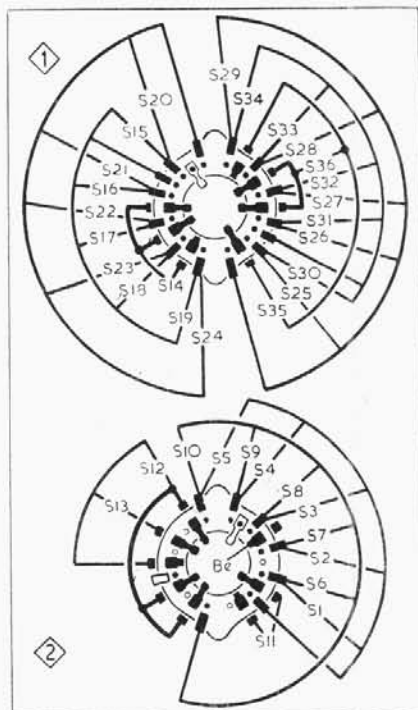

Switch	L.W.	M.W.	49 m	31 m	16 m
S1	—	C	C	C	C
S2	C	C	C	C	C
S3	—	C	C	C	C
S4	C	C	C	C	C
S5	C	C	C	C	C
S6	C	—	—	—	—
S7	—	C	—	—	—
S8	—	—	C	—	—
S9	—	—	—	C	—
S10	—	—	—	—	C
S11	C	C	—	—	—
S12	C	C	C	C	C
S13	C	C	C	C	C
S14	—	—	C	C	C
S15	C	—	—	C	C
S16	—	C	—	—	—
S17	—	—	C	—	—
S18	—	—	—	C	—
S19	—	—	—	—	C
S20	—	—	—	—	C
S21	—	C	C	C	C
S22	C	C	C	C	C
S23	C	C	C	C	C
S24	C	C	C	C	C
S25	C	C	C	C	C
S26	C	C	C	C	C
S27	C	C	C	C	C
S28	C	C	C	C	C
S29	C	C	C	C	C
S30	C	C	C	C	C
S31	—	C	—	—	—
S32	—	—	C	—	—
S33	—	—	—	C	—
S34	—	—	—	—	C
S35	—	C	—	—	—
S36	—	C	C	C	C

to the substitute scale reading, quoted in each case, after dividing it by two.

L.W.—Switch receiver to L.W., tune to 52 on substitute scale, feed in a 214 kc/s (1,400 m) signal and adjust the cores of **L7** (G3) and **L2** (G4) for maximum output. Repeat these adjustments.

M.W.—Switch receiver to M.W., tune to 85 on scale, feed in a 600 kc/s (500 m) signal and adjust the cores of **L8** (G3) and **L3** (G4) for maximum output. Tune receiver to 15 on scale, feed in a 1,500 kc/s (200 m) signal and adjust **C37** (G3) and **C35** (G4) for maximum output. Repeat these adjustments until no further improvement results.

49 m band.—Switch receiver to 49 m, tune to 50 on scale, feed in a 6.1 Mc/s (49.18 m) signal and adjust the cores of **L9** (G4) and **L4** (G4) for maximum output.

31 m band.—Switch receiver to 31 m, tune to 50 on scale, feed in a 9.6 Mc/s (31.25 m) signal and adjust the cores of **L10** (F4) and **L5** (G4) for maximum output.

16 m band.—Switch receiver to 16 m, tune to 50 on scale, feed in a 17.8 Mc/s (16.85 m) signal and adjust the cores of **L11** (F3) and **L6** (F4) for maximum output.

DRIVE CORD REPLACEMENT

About five feet of nylon braided glass yarn is required for a new drive cord in the table models, this length leaving an ample margin for tying off. The makers quote the exact length of the made-up cord as 50in between the centres of the end-loops.

The cord should be run as shown in the left-hand sketch, seen above in cols. 5 and 6, where the system is drawn as seen when viewed from the rear of the chassis when the gang is at maximum capacitance. Both ends of the cord are looped on to the same end of the tension spring, and may be made up like that in advance and fitted as a complete loop if desired.

Four feet is sufficient for the cord in the P45RG, whose exact length the makers give as 42 1/2 in. The system as seen from the rear is shown in the right-hand sketch.

Diagrams of the two waveband switch units as they appear in all three models when viewed from the rear of an inverted chassis. On the right is the associated switch table.