

# PYE T19D, 19RG

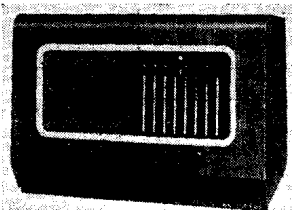

Five-valve, eight-waveband superhet with bandspread on the five short wavebands. Sockets are fitted for gramophone pickup and low-impedance extension speaker. Suitable for 200-250V 40-100c/s.

Model T19D is housed in a walnut veneered table type cabinet. A similar chassis is incorporated in television model LV21RG and in radiogram model 19RG, which is fitted with automatic record changer and housed in an upright floor cabinet having drop down doors to radio and auto-changer compartments. Made by Pye, Ltd., Cambridge.

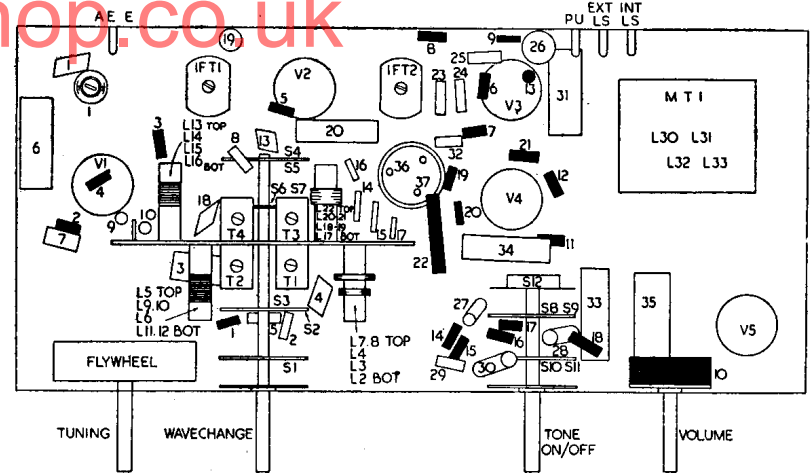
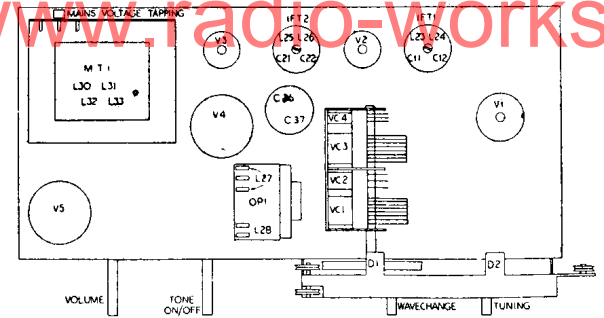

### RESISTORS

| R  | Ohms | Watts | R  | Ohms | Watts | L  | Ohms     |
|----|------|-------|----|------|-------|----|----------|
| 1  | 1M   |       | 15 | 4.7M |       | 6  | .5       |
| 2  | 220  |       | 16 | 10K  |       | 7  | 12.5     |
| 3  | 15K  |       | 17 | 18K  |       | 8  | .75      |
| 4  | 47K  |       | 18 | 10K  |       | 9  | 42       |
| 5  | 330  |       | 19 | 470K |       | 10 | 2.5      |
| 6  | 1M   |       | 20 | 22K  |       | 11 | 250      |
| 7  | 1M   |       | 21 | 150  |       | 12 | 17       |
| 8  | 100K |       | 22 | 1.8K |       | 13 | Very low |
| 9  | 470K |       |    |      |       | 14 | Very low |
| 10 | 1M   | Potr. |    |      |       | 15 | Very low |
| 11 | 33K  |       |    |      |       | 16 | Very low |
| 12 | 220K |       |    |      |       | 17 | Very low |
| 13 | 6.8K |       |    |      |       | 18 | Very low |
| 14 | 2.2M |       |    |      |       | 19 | Very low |
|    |      |       |    |      |       | 20 | 2        |

### INDUCTORS

| L | Ohms |
|---|------|
| 1 | 32   |
| 2 | 17   |
| 3 | 18   |
| 4 | 19   |
| 5 | 20   |

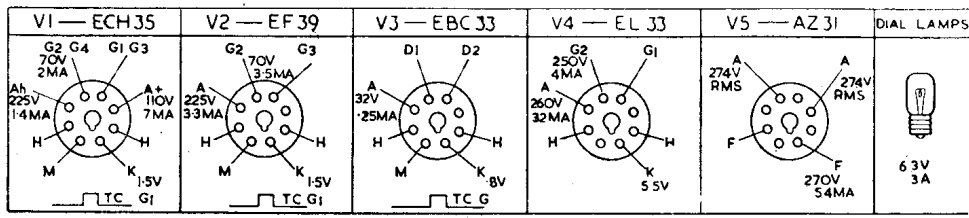
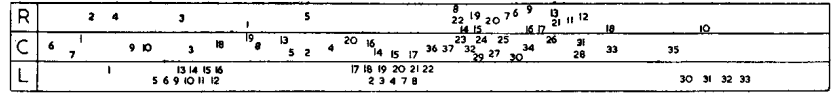

| R  | Ohms        |
|----|-------------|
| 21 | .4          |
| 22 | .4          |
| 23 | 10          |
| 24 | 10          |
| 25 | 10          |
| 26 | 10          |
| 27 | 460 Total   |
|    | 16.5 Tapped |
| 28 | .5          |
| 29 | 2.5         |
| 30 | Very low    |
| 31 | 500         |
| 32 | Very low    |
| 33 | 40 Total    |

### CAPACITORS

| C  | Capacity            | Type        | C  | Capacity        | Type    |
|----|---------------------|-------------|----|-----------------|---------|
| 14 | 1700pF              | Silver Mica | 28 | .05 Tubular     | 350V    |
| 15 | 500pF               | Silver Mica | 29 | 20pF            | Ceramic |
| 16 | 200pF               | Silver Mica | 30 | .05 Tubular     | 350V    |
| 17 | 150pF               | Silver Mica | 31 | .005 Tubular    | 1000V   |
| 18 | 125pF               | Silver Mica | 32 | 10pF            | Ceramic |
| 19 | .05 Tubular         | 500V        | 33 | 2 Electrolytic  | 450V    |
| 20 | .01 Tubular         | 350V        | 34 | .01 Tubular     | 1000V   |
| 21 | (100) 140pF         | Silver      | 35 | 50 Electrolytic | 12V     |
| 22 | (100) 140pF         | Mica        | 36 | 32 Electrolytic | 450V    |
| 23 | 100pF               | Ceramic     | 37 | 32 Electrolytic | 450V    |
| 24 | 100pF               | Ceramic     | 38 | 100pF           | Ceramic |
| 25 | (.002) .005 Tubular | 500V        | 39 | 100pF           | Ceramic |
| 26 | 50 Electrolytic     | 12V         |    |                 |         |
| 27 | .002 Tubular        | 500V        |    |                 |         |

NOTE.—Capacitor values in brackets are for modified T19T chassis.

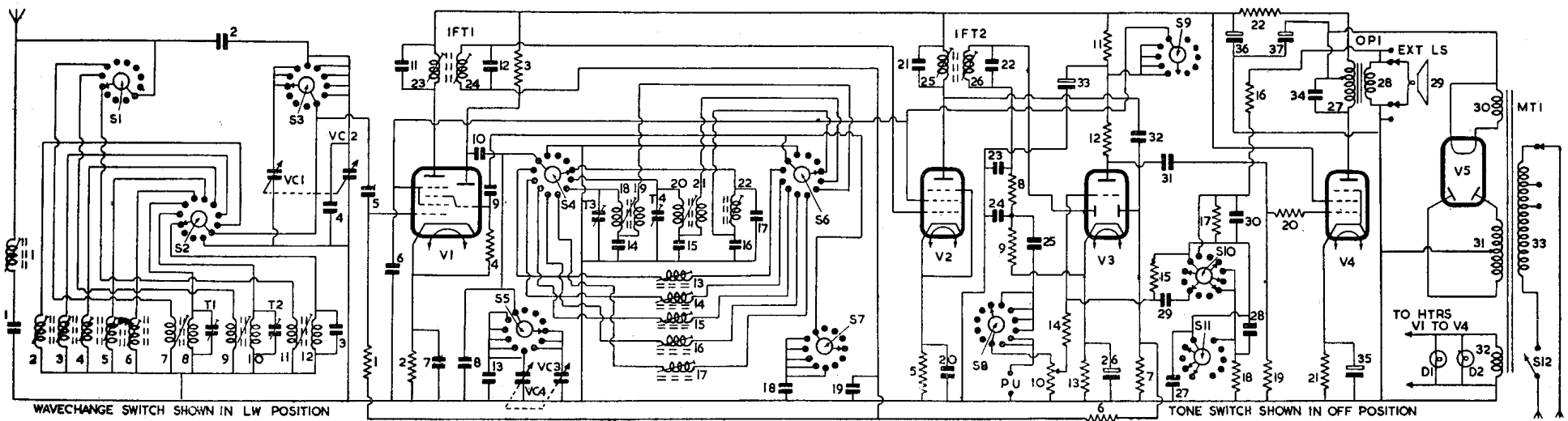

PYE T19D, 19RG

Continued

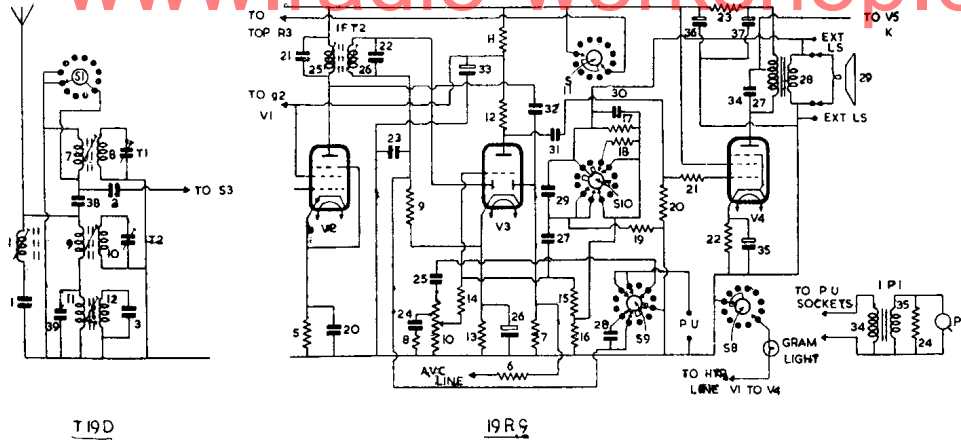
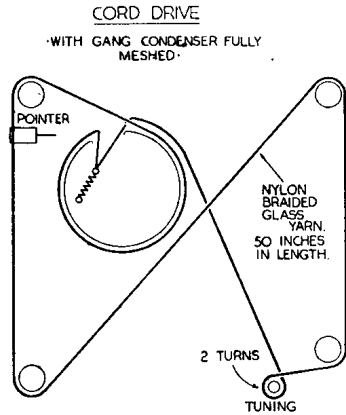

RESISTORS

| R  | Ohms                    | Watts |
|----|-------------------------|-------|
| 8  | 47K                     | ...   |
| 10 | 1M Tapped Potentiometer | ...   |
| 15 | 10M                     | ...   |
| 16 | 100K                    | ...   |
| 17 | 220K                    | ...   |
| 18 | 3.3K                    | ...   |
| 19 | 220K                    | ...   |
| 20 | 470K                    | ...   |
| 21 | 22K                     | ...   |
| 22 | 150                     | ...   |
| 23 | 1.8K                    | ...   |
| 24 | 22K                     | ...   |

CAPACITORS

| C  | Capacity     | Type    |
|----|--------------|---------|
| 24 | .02 Tubular  | 500V    |
| 25 | .01 Tubular  | 1000V   |
| 27 | 33pF         | Ceramic |
| 29 | 22pF         | Ceramic |
| 30 | .01 Tubular  | 350V    |
| 28 | .001 Tubular | 350V    |
| 34 | .005 Tubular | 600VAC  |

INDUCTORS

| L  | Ohm  |
|----|------|
| 34 | 1.1K |
| 35 | 7K   |

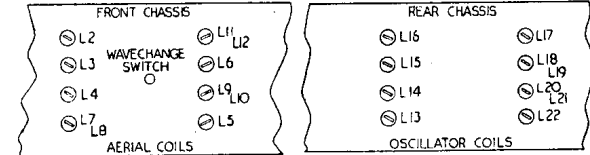

**AERIAL** is fed to IF filter L1, C1 and on LW, MW, and MSW ranges it is switched by S1 to aerial coupling coils L11, L9, L7 respectively. On the five bandspread SW ranges, however, the aerial signal is coupled through C2 to S3 and thence switched by S2 to top of grid tuned coils L2 to L6.

The grid coils L2 to L6, L7, L9, L11 are switched by S2, S3 to aerial tuning capacitor VC1 (LW, MW, MSW) and VC2 shunted by C4 on the bandspread SW ranges. The tuned coils are then coupled by C5 to triode-hexode frequency changer V1. T1 (MSW), T2 (MW) and C3 (LW) are capacity trimmers and all coils are permeability tuned.

AVC decoupled by R6, C19 is fed by R1 to V1. Cathode bias is provided by R2 decoupled by C7. Screen voltage, decoupled by C6, is obtained from R11 through S9. Primary L23, C11 of IFT1 is in the hexode anode circuit of V1.

Oscillator is connected in a tuned anode, shunt fed circuit. The tuned coils L13, to L17, L18, L20, L22, are switched by S4 through C10 to oscillator anode and again switched by S5 to tuning capacitor VC3 (LW, MW, MSW) and VC4 shunted by C13 on the bandspread SW ranges. T3 (MSW), T4 (MW), C17 (LW) are capacity trimmers and all coils are permeability tuned.

C14 (MSW), C15 (MW), C16 (LW), together with C18 which is switched in by S7 on the five SW ranges, are padding capacitors. The grid reaction voltages are developed inductively from L19 (MSW), L21 (MW), and capacitively from across padders C16 (LW), C18 (SW) and are switched by S6 through C9 to oscillator grid.

Automatic bias for grid is developed on C9 with R4 as leak resistor. R3 is the oscillator anode load.

IF amplifier operates at 465kc/s. Secondary L24, C12 of IFT1 feeds signal, and AVC voltages decoupled by R6, C19 to IF amplifier V2. Cathode bias is provided by R5 decoupled by C20. Screen voltage is obtained from R11 through S9, decoupled by C6. Primary L25, C21 of IFT2 is in the anode circuit.

**Signal rectifier**—Secondary L26, C22 of IFT2 feeds signal to one diode of V3. R9 is diode load and R8, C23, C24 an RF filter.

**AF amplifier**—Rectified signal across R9 is fed by C25 to S8 which, in its four radio positions, switches signal through to volume control R10 and thence through R14 to grid of triode section of V3. Cathode bias is provided by R13 decoupled by C26. R12 is anode load and R11, C33 give decoupling to HT feed to screens of V1, V2 and anode V3.

AVC.—C32 feeds signal at anode V2 to second diode of V3. R7 is diode load and R6, C19 give line decoupling to V1, V2. Cathode bias developed across R13 provides AVC line delay voltage.

**Output stage**—C31 feeds signal through grid stopper R20 to pentode output valve V4. R19 is its grid resistor. Cathode bias is provided by R21 decoupled by C35. Screen voltage is obtained direct from HT line to V1 to V3. Primary L27 of output matching transformer OPI is in the anode circuit. C34 gives fixed tone control. Secondary L28 feeds signal to an 8 in. PM speaker L29.

Sockets are fitted on L28 for a low-impedance extension speaker.

**Negative feedback** from secondary L28 of OPI is fed by R16 through a switch-controlled selective negative feedback tone-control circuit consisting of S10, S11 together with R17, C30, R15, C29, R18, C28, to grid of AF amplifier section of V3.

**Pickup** sockets are provided on the rear of chassis for connection of a high-resistance pickup. PU signal is switched by S8, in its two gram positions, to top of volume control R10.

S9 which is ganged to the combined tone and radiogram switch removes the HT to screens of V1, V2 to prevent radio break-through when pickup is in use.

HT is provided by a directly-heated fullwave rectifier V5. Its anode voltages are obtained from HT secondary L31 of mains input transformer MT1, and its heater current from secondary L30. Smoothing is given by R22, C36, C37, together with section of primary L27 of OPI. C37 should be rated for 80mA ripple current.

Heaters of V1 to V4 and dial lights obtain their current from secondary L32 one side of which is connected down to chassis. Primary L33 of MT1

TRIMMING INSTRUCTIONS

| Apply signal as stated below                | Tune receiver to | Trim in order stated for maximum output |
|---|------------------|---|
| (1) 465 kc/s to g1 of V1 via .1 capacitor   | 550 metres       | Cores L26, L24, L23                     |
| (2) 465 kc/s to aerial socket via dummy AE  | 550 metres       | Core L1 for minimum                     |
| (3) 225 kc/s as above ...                   | LW 1330 metres   | Core L22, L12                           |
| (4) 600 kc/s as above ...                   | MW 500 metres    | Core L20, L10                           |
| (5) 1.5 mc/s as above ...                   | MW 200 metres    | T4, T2. Repeat (4) and (5)              |
| (6) 1.5 mc/s as above ...                   | MSW 1.5 mc/s     | Core L18, L8                            |
| (7) 3.3 mc/s as above ...                   | MSW 3.3 mc/s     | T3, T1. Repeat (6) and (7)              |
| (8) 6.1 mc/s via 400Ω resistor to AE socket | 49M 6.1 mc/s     | Cores L17, L6                           |
| (9) 9.6 mc/s as above ...                   | 31M 9.6 mc/s     | Cores L16, L5                           |
| (10) 11.8 mc/s as above                     | 25M 11.8 mc/s    | Cores L15, L4                           |
| (11) 15.3 mc/s as above                     | 19M 15.3 mc/s    | Cores L14, L3                           |
| (12) 17.8 mc/s as above                     | 16M 17.8 mc/s    | Cores L13, L2                           |

coupling coils L9 (MW), L11 (LW) and coupled through C38 to MSW aerial coil L7. The LW coil L11 has a shunt capacitor C39 connected across it. S1 is used to short circuit L7 (MSW) on LW and MW ranges and in effect connects C38 across L9, L11 to earth. On the bandspread SW ranges, aerial signal is fed through C38 and C2 to S3 and thence via S2 to top of the grid tuned coils L2 to L6.

MODEL 19RG

The chassis incorporated in the radiogram Model 19RG is similar to that of the T19D with the exception that tone control and associated switching circuits are as shown in special diagram. On gram position of tone control switch the oscillator HT is removed instead of screens of V1 and V2. Certain of the components occupy a different circuit position and are of a different value. A table showing components differing or in addition to those of Model T19D is given above.

It should be noted that the pickup is connected to the chassis sockets by a transformer IPI with secondary L35 damped by resistor R24.

O/C TRANSFORMERS

**E**IGHT days after a new output transformer had been fitted to an Ekco push-button set, owing to the original developing a break in the primary, the replacement itself broke down in a similar manner.

As the new transformer, similar to the original one, was of sound construction and ample current carrying capacity, it was decided to soak-test the receiver after fitting yet another replacement, but with a surge limiting resistor across it.

After many hours of operation, the reason for the transformer primaries breaking down became obvious. Now and then, and perhaps for only a fraction of a second, the speech coil of the speaker would go OC.

It being a powerful set, usually operated at high volume, this interruption of load could create a large EMF across the output transformer primary. —G. R. Wilding, Liverpool.

is tapped for 200-215, 216-235, 236-250V, 40 to 100c/s AC. S12, which is coupled to radiogram tone switch, is the receiver ON/OFF switch.

MODIFICATIONS

Later versions of this receiver have a slightly different aerial input circuit as shown in separate diagram above. The aerial is fed to IF filter L1, C1 and is taken to top of series connected aerial