

R. F. I.

Vacuum tube base connections.

6K8G—

1—Blank ; 2—Heater ; 3—Plate ; 4—Screen ; 5—Osc. Grid ;
6—Osc. Plate ; 7—Heater ; 8—Cathode.

The I.F. Transformer Can may be taken off without disconnecting any leads by removing the two nuts on top of it. The intermediate frequency is 365 kc.

Alignment frequencies in decreasing order of frequency are 42 Mc. ; 30 Mc. ; 18 Mc. ; 1425 kc. and 570 kc. ; 300 kc. and 150 kc. No padder is used on S.W.1 or S.W.2., on S.W.3. the value is .005 fixed.

An inspection cover in the base of cabinet will often enable a repair to be carried out without removing the chassis from the cabinet.

Radio to Gramophone switching operates on the front bank of the wave change switch. Weak radio reception may sometimes be traced to a fault on this bank.

On medium and long waves a Colpitts oscillator is used, which has no tickler coil.

To prolong dial lamp life a resistance wire of 26 s.w.g. Constantan connects the 6.3 volt heater to the third bank on the wave change switch and thence by copper wire to the dial lights. Should this resistance burn out, the cause may be a lamp or holder shorting to the scale carrier.

R.A.P. MODELS 646 CONTAIN THE FOLLOWING:

RFI

IFI

POWER I.

R.F.I.

Parts List

C1	68.0	picofarads
C2	35.0	picofarads
C3	.05	microfarad
C4	.05	microfarad
C5	.05	microfarad
C6	.001	microfarad
C7	50.0	picofarads
C8	.005	microfarad
C9	350.0	picofarads
C10	.05	microfarad
C11	65.0	picofarads

R1	470.0 kilohms	$\frac{1}{4}$ watt
R2	56.0 kilohms	$\frac{1}{4}$ watt
R3	240.0 ohms	$\frac{1}{4}$ watt
R4	47.0 kilohms	$\frac{1}{4}$ watt
R5	47.0 kilohms	$\frac{1}{4}$ watt

RFI

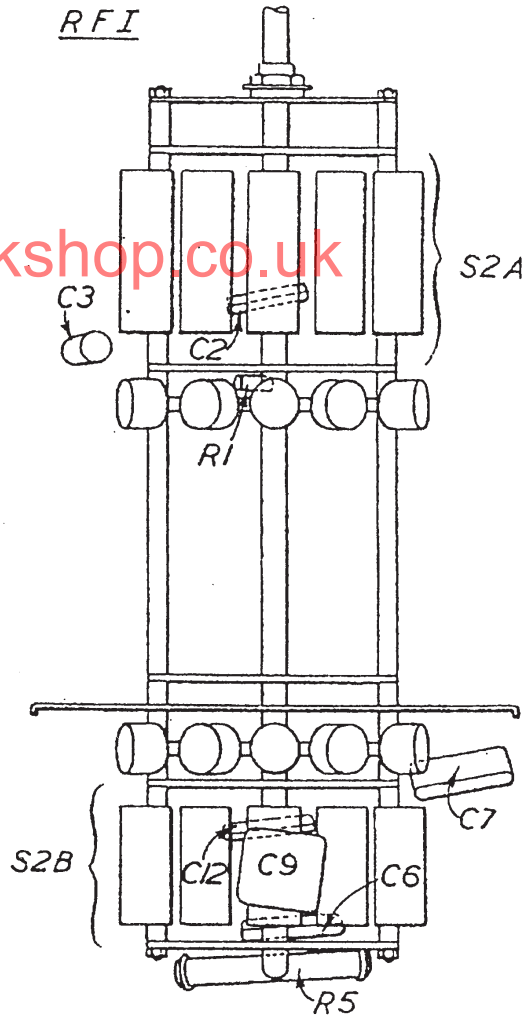

RFI

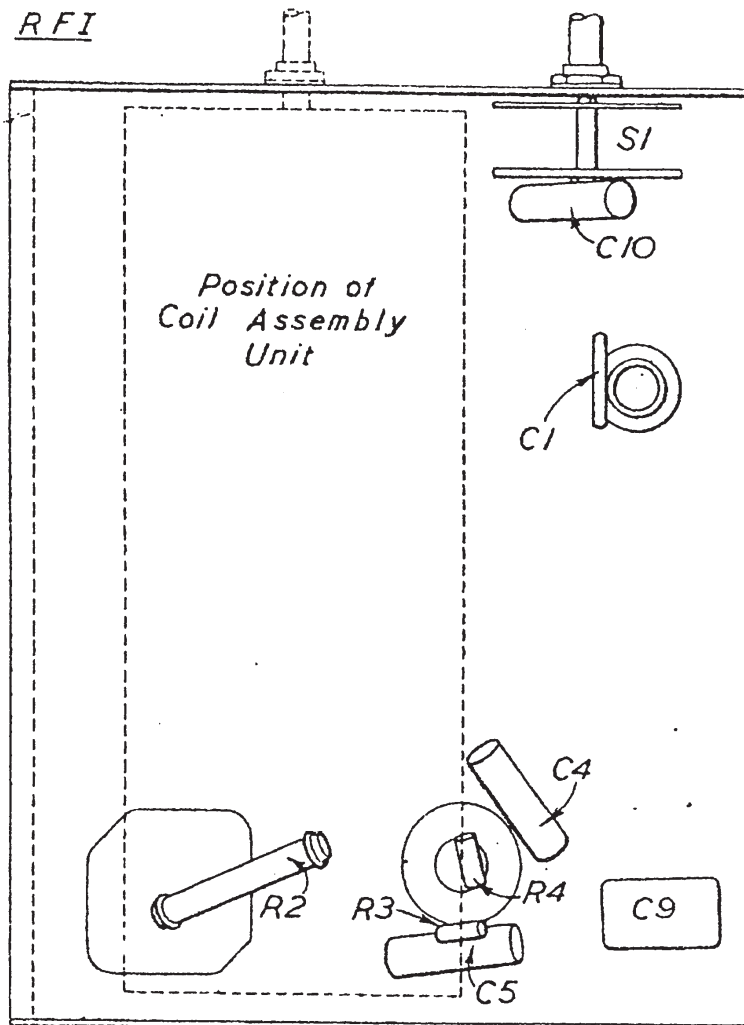

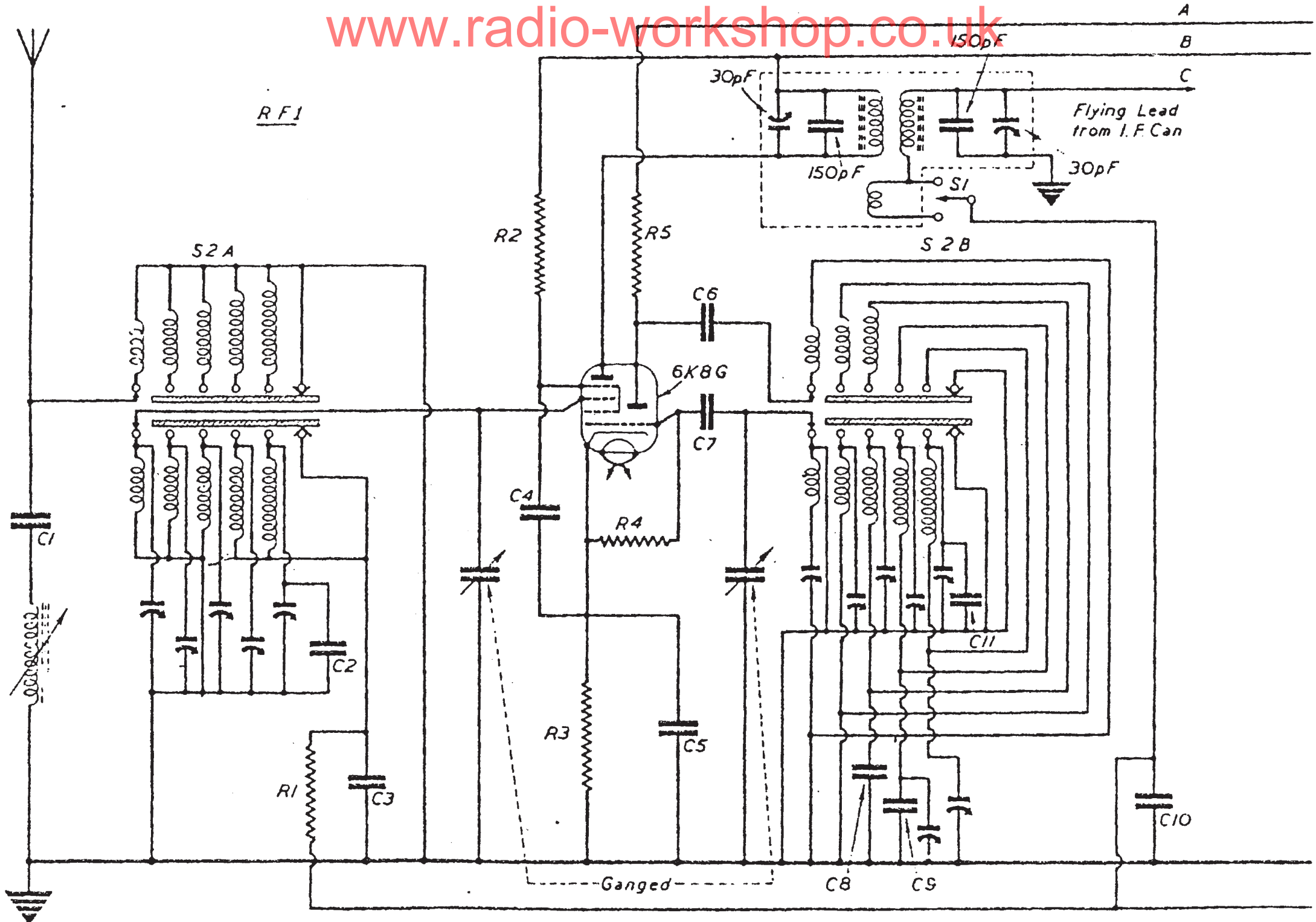

R. F. 2.

Vacuum tube base connections.

6K7G—

1—Blank ; 2—Heater ; 3—Plate ; 4—Screen ; 5—Suppressor ;
6—Blank ; 7—Heater ; 8—Cathode.

6K8G—

1—Blank ; 2—Heater ; 3—Plate ; 4—Screen ; 5—Osc. Grid ; 6—
Osc. Plate ; 7—Heater ; 8—Cathode.

The I.F. Transformer Can may be taken off without disconnecting any leads by removing the two nuts on top of it. The intermediate frequency is 365 kc.

Alignment frequencies in decreasing order of frequency are 42 Mc. ; 30 Mc. ; 18 Mc. ; 1425 kc. and 570 kc. ; 300 kc. and 150 kc. No padder is used on S.W.1. or S.W.2., on S.W.3. the value is .005 fixed.

An inspection cover in the base of the cabinet will often enable a repair to be effected without removing the chassis from the cabinet.

Radio to Gramophone switching operates on the front bank of the wave change switch. Weak reception on radio may sometimes be traced to a fault on this bank.

On medium and long waves a Colpitts oscillator circuit is used, which has no tickler coil.

To prolong dial lamp life a resistance wire of 26 s.w.g. connects the 6.3 heater to the fourth bank of the wave change switch and thence by copper wire to the dial lights. Should this resistance burn out, the cause may be a lamp or holder shorting to the scale carrier.

The primary of the S.W.2. R.F. Transformer is wound with 40 s.w.g. resistance wire.

R.A.P. MODELS TYPE 846 CONTAIN FOLLOWING UNITS :-

RF2

IF1

POWER 2.

R.F. 2.

Parts List

C1	68.0	picofarads
C2	.05	microfarad
C3	35.0	picofarads
C4	.05	microfarad
C5	.05	microfarad
C6	35.0	picofarads
C7	.05	microfarad
C8	.05	microfarad
C9	.05	microfarad
C10	.001	microfarad
C11	50.0	picofarads
C12	65.0	picofarads
C13	.005	microfarad
C14	350.0	picofarads

R1	330 ohms	$\frac{1}{4}$ watt
R2	100 kilohms	$\frac{1}{4}$ watt
R3	470 kilohms	$\frac{1}{4}$ watt
R4	100 kilohms	$\frac{1}{4}$ watt
R5	56 kilohms	1 watt
R6	240 ohms	$\frac{1}{4}$ watt
R7	47 kilohms	$\frac{1}{4}$ watt
R8	47 kilohms	1 watt

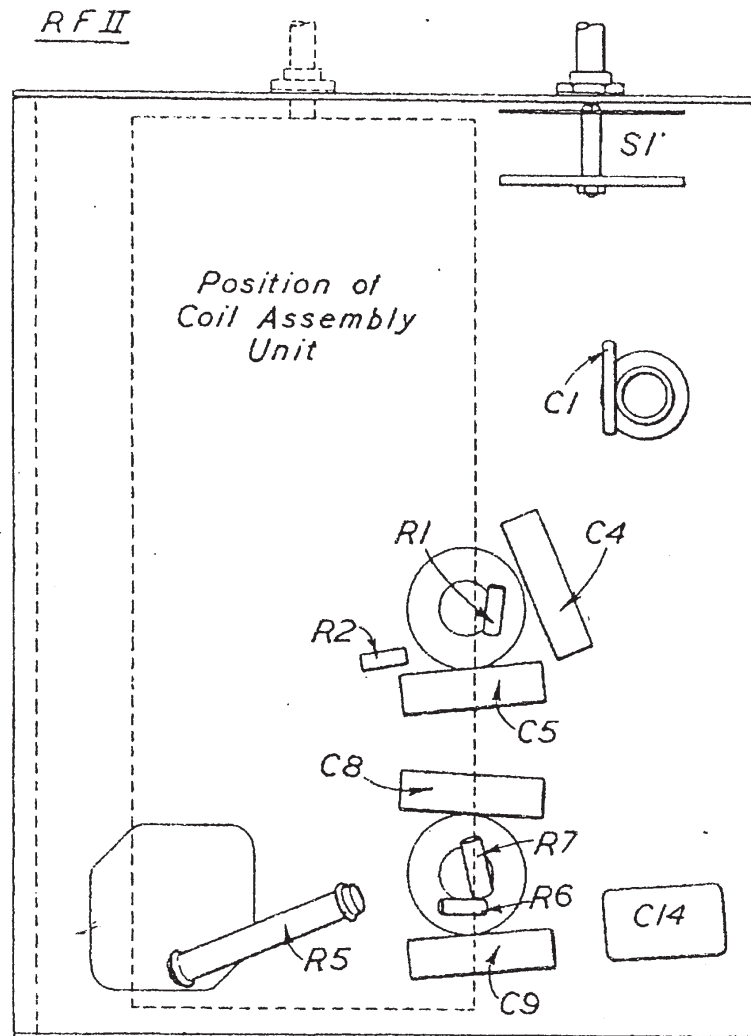
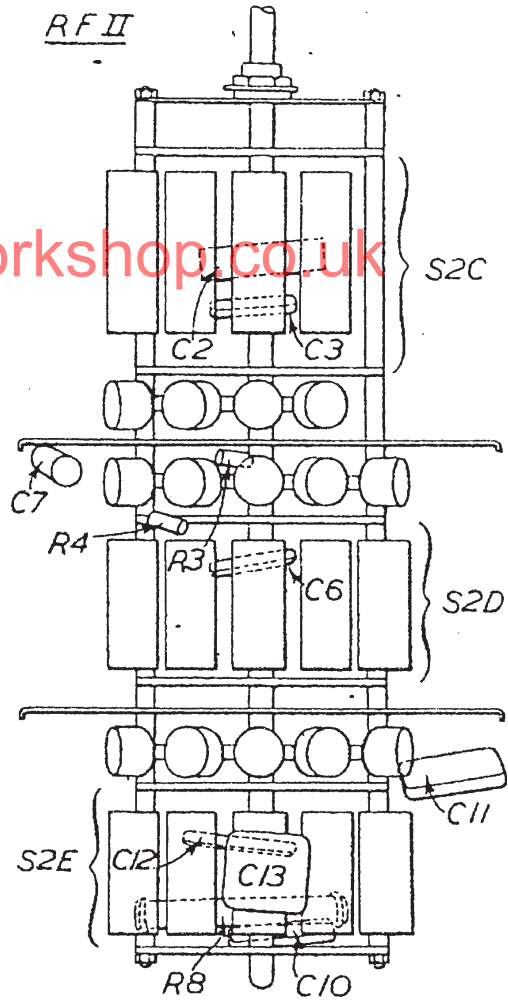

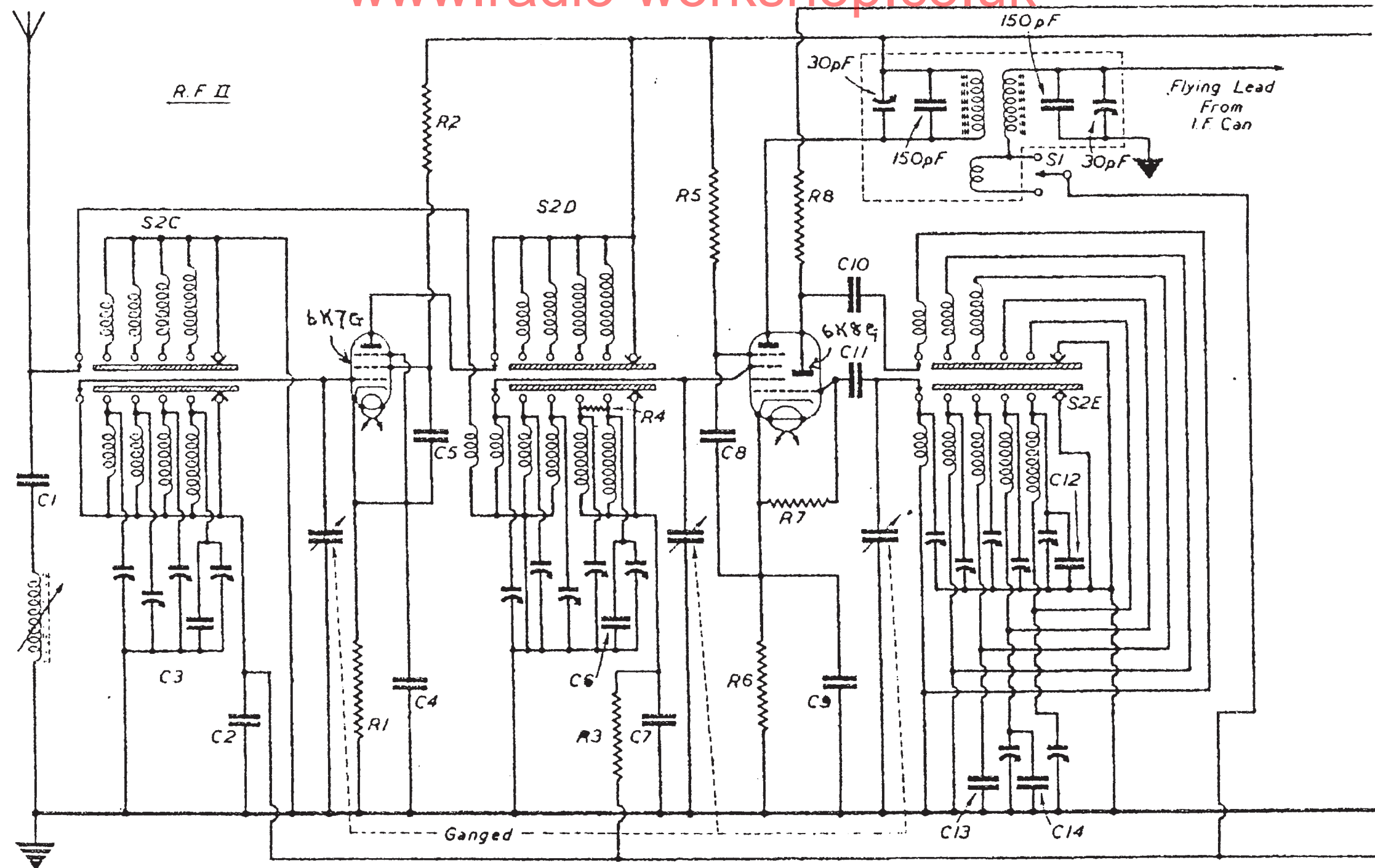

I. F. I.

Vacuum tube base connections.

6K7G—

1—Blank ; 2—Heater ; 3—Plate ; 4—Screen ; 5—Suppressor ;
6—Blank ; 7—Heater ; 8—Cathode.

6Q7G—

1—Blank ; 2—Heater ; 3—Plate ; 4 and 5—Diode Plates ; 6—Blank ;
7—Heater ; 8—Cathode.

The auxillary components in the I.F. Transformer may be measured from the tag plate of this transformer. See circuit diagram.

The I.F. Transformer Can may be taken off without disconnecting any leads by removing the two nuts on top of it. The Intermediate frequency is 365 Kc.

An inspection cover in the base of the cabinet will often enable a repair to be effected without removing the chassis from the cabinet.

Noise when operating the volume control can sometimes be caused by a soft 6Q7 or the 6Q7 bias resistance being shorted, the control in itself not being faulty.

Parts List

I F I

C1	.05 microfarad
C2	.05 microfarad
C3	0.25 microfarad
C4	25.0 microfarads
C5	100.0 picofarads
C6	.01 microfarad
C7	.01 microfarad

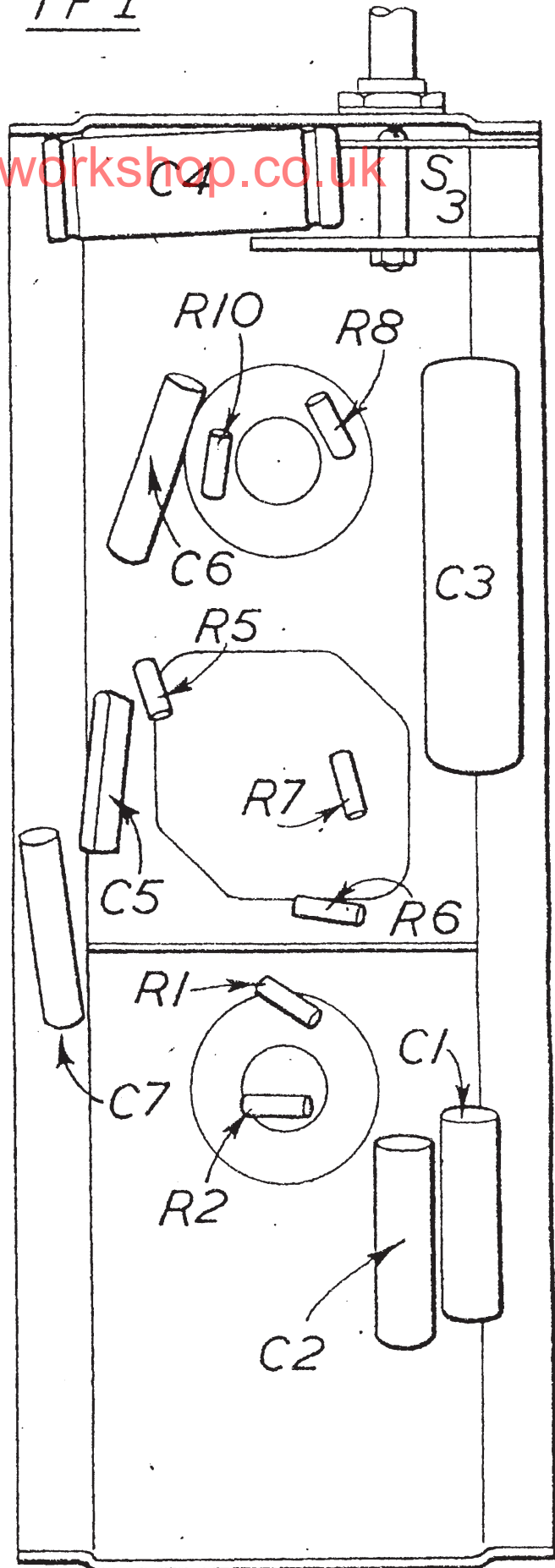

R1	100 kilohms	1 watt
R2	330 ohms	$\frac{1}{4}$ watt
R3	470 kilohms	$\frac{1}{4}$ watt
R4	470 kilohms	$\frac{1}{4}$ watt
R5	100 kilohms	$\frac{1}{4}$ watt
R6	68 kilohms	$\frac{1}{4}$ watt
R7	220 kilohms	$\frac{1}{4}$ watt
R8	47 kilohms	$\frac{1}{4}$ watt
R9	Volume Control	
R10	470 kilohms	$\frac{1}{4}$ watt

Volume Control resistors comprising R9.

a—270 kilohms ; b—270 kilohms ; c—120 kilohms ; d—68 kilohms ; e— 33 kilohms ; f—15 kilohms ; g—8.2 kilohms ; h—3.9 kilohms ; j—2.2 kilohms ; k—1.0 kilohm ; l—.47 kilohm ; m—.22 kilohm ; n—.12 kilohm ; p—.12 kilohm.

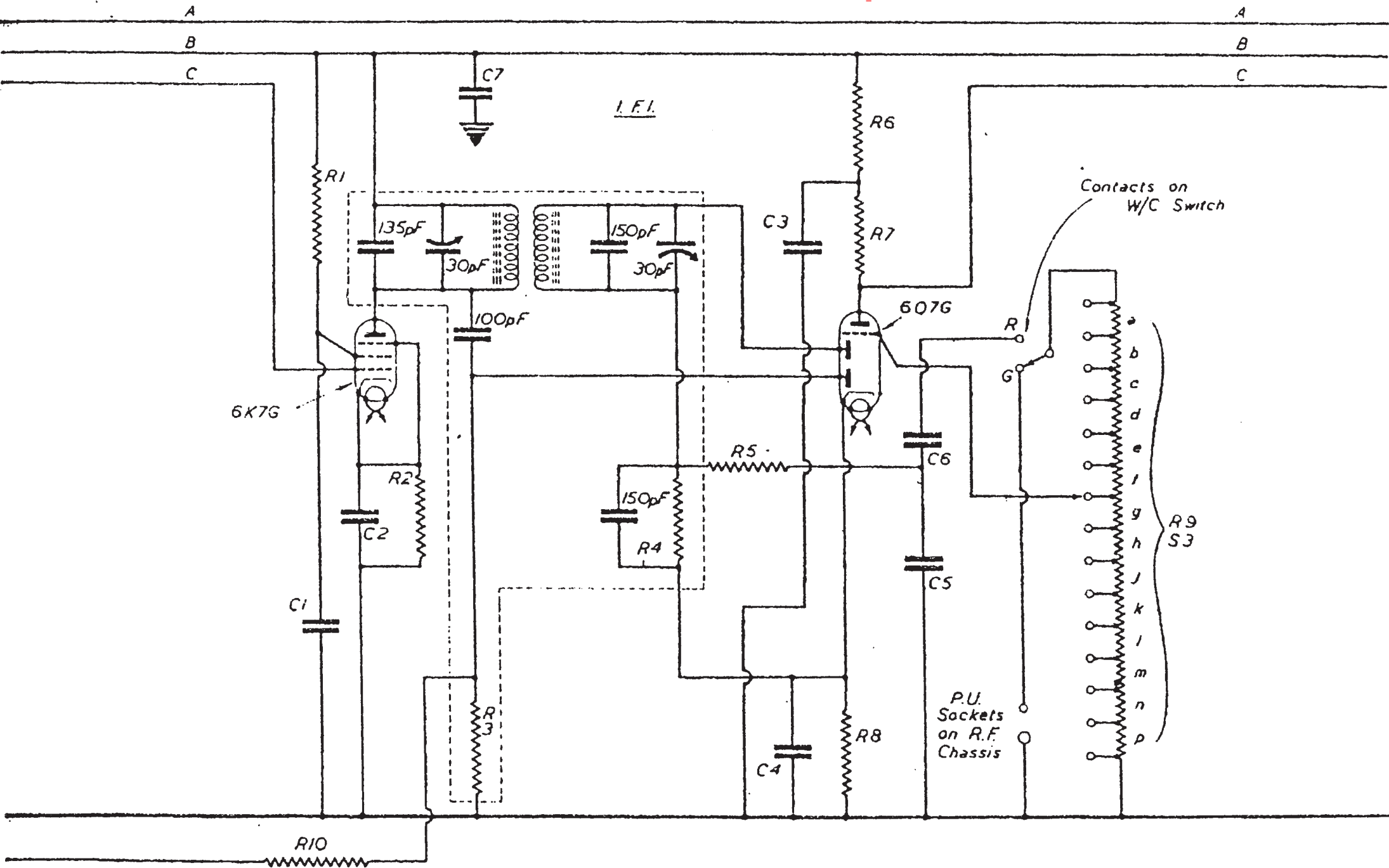

POWER I.

Vacuum tube base connections. www.radio-workshop.co.uk

6V6G—

1—Blank ; 2—Heater ; 3—Plate ; 4—Screen ; 5—Grid ; 6—Blank ;
7—Heater ; 8—Cathode.

5Z4G—

1—Blank ; 2—Heater ; 3, 5 and 7—Blank ; 4 and 6—Plates ;
8—Heater and Cathode.

An inspection cover in the base of the cabinet will often enable a repair to be effected without removing the chassis from the cabinet.

It should be noted that, in the off position of the tone control and mains switch, the grid of the 6V6 is shorted to the chassis. Bear this in mind when checking resistances in this part of the circuit.

Unless a speaker is connected to the external speaker plug it must never be fully inserted into its socket. If this should occur, the output tube may be damaged.

Power I. Parts List

C1	.01	microfarad
C2	.005	microfarad
C3	.002	microfarad
C4	500.0	picofarads
C5	25.0	microfarads
C6	4.0	microfarads
C7	8.0	microfarads
C8	8.0	microfarads

R1	470 kilohms	$\frac{1}{2}$ watt
R2	270 ohms	2 watts
R3	47 kilohms	1 watt

www.radio-workshop.co.uk

POWER I.

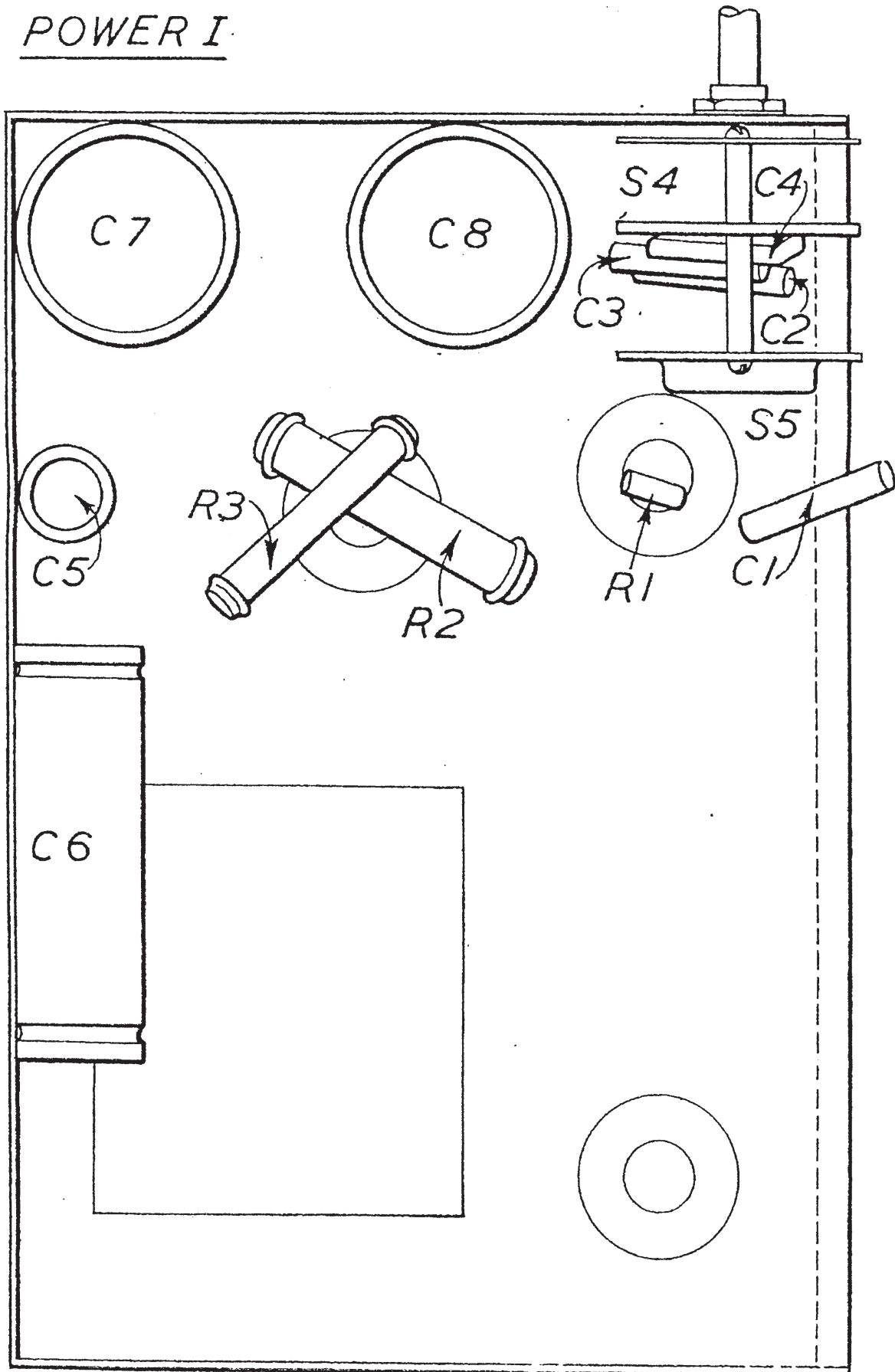

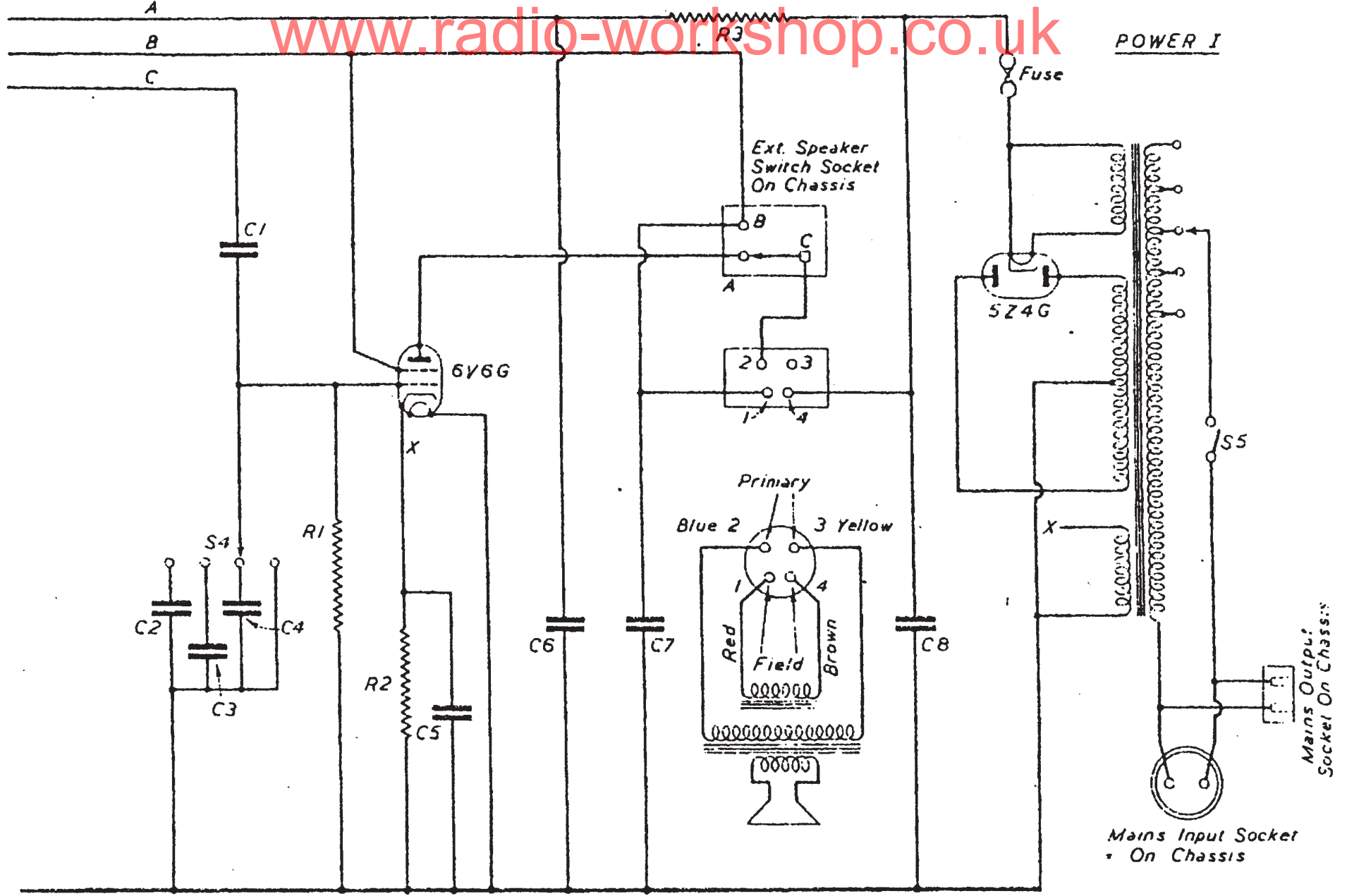

A and B are extension loudspeaker sockets. Extension speaker is connected to plug. C is connected to A until plug is fully inserted. When plug is partly inserted both speakers are in operation. When plug is fully inserted A is disconnected from C and extension speaker only is in operation. Internal speaker socket viewed from below chassis and plug with pins pointing towards observer.

POWER 2.

www.radio-workshop.co.uk

Vacuum tube base connections.

6J5G—

1—Blank ; 2—Heater ; 3—Plate ; 4 and 6—Blank ; 5—Grid ;
7—Heater ; 8—Cathode.

6V6G—

1—Blank ; 2—Heater ; 3—Plate ; 4—Screen ; 5—Grid ; 6—Blank ;
7—Heater ; 8—Cathode.

5Z4G—

1—Blank ; 2—Heater ; 3, 5 and 7—Blank ; 4 and 6—Plates ; 8—
Heater and Cathode.

An inspection cover in the base of the cabinet will often enable a repair to be effected without removing the chassis from the cabinet.

It should be noted that, in the off position of the tone control and mains switch, the grid of the 6J5G phase inverter is shorted to the junctions of resistors R2 and R5. Bear this in mind when checking resistances in this part of the circuit.

Unless a speaker be connected to the external speaker plug it must never be completely inserted. If this should occur, an output tube may be damaged.

Power 2. Parts List

C1	.01	microfarad
C2	.005	microfarad
C3	.002	microfarad
C4	500.0	picofarads
C5	4.0	microfarads
C6	4.0	microfarads
C7	.01	microfarad
C8	.01	microfarad
C9	25.0	microfarads
C10	8.0	microfarads
C11	8.0	microfarads

www.radio-workshop.co.uk

POWER II

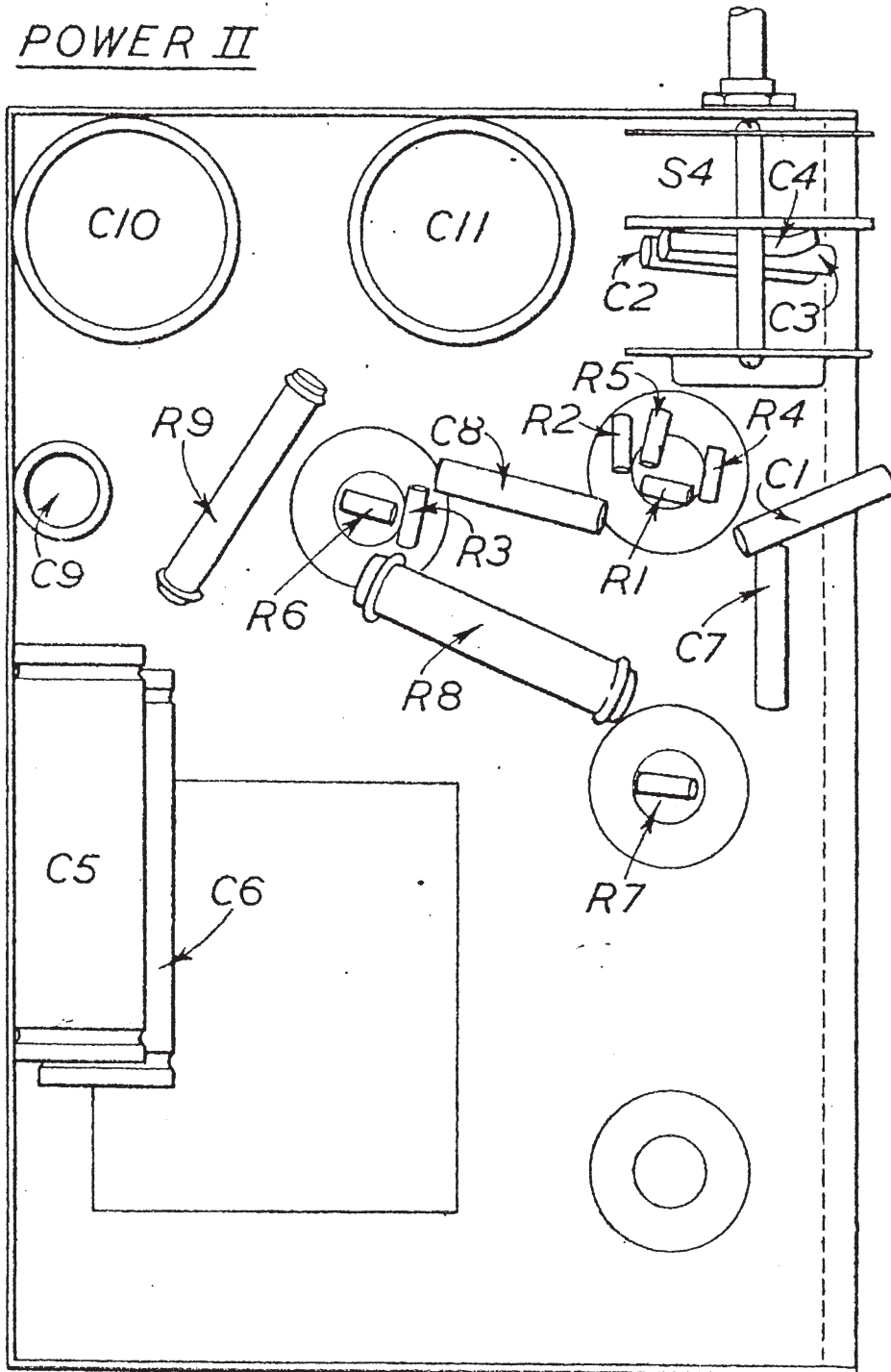

R1	470.0 kilohms	$\frac{1}{4}$ watt
R2	4.7 kilohms	$\frac{1}{4}$ watt
R3	4.7 kilohms	$\frac{1}{4}$ watt
R4	33.0 kilohms	$\frac{1}{4}$ watt
R5	33.0 kilohms	$\frac{1}{4}$ watt
R6	470.0 kilohms	$\frac{1}{4}$ watt
R7	470.0 kilohms	$\frac{1}{4}$ watt
R8	220.0 ohms	2 watts

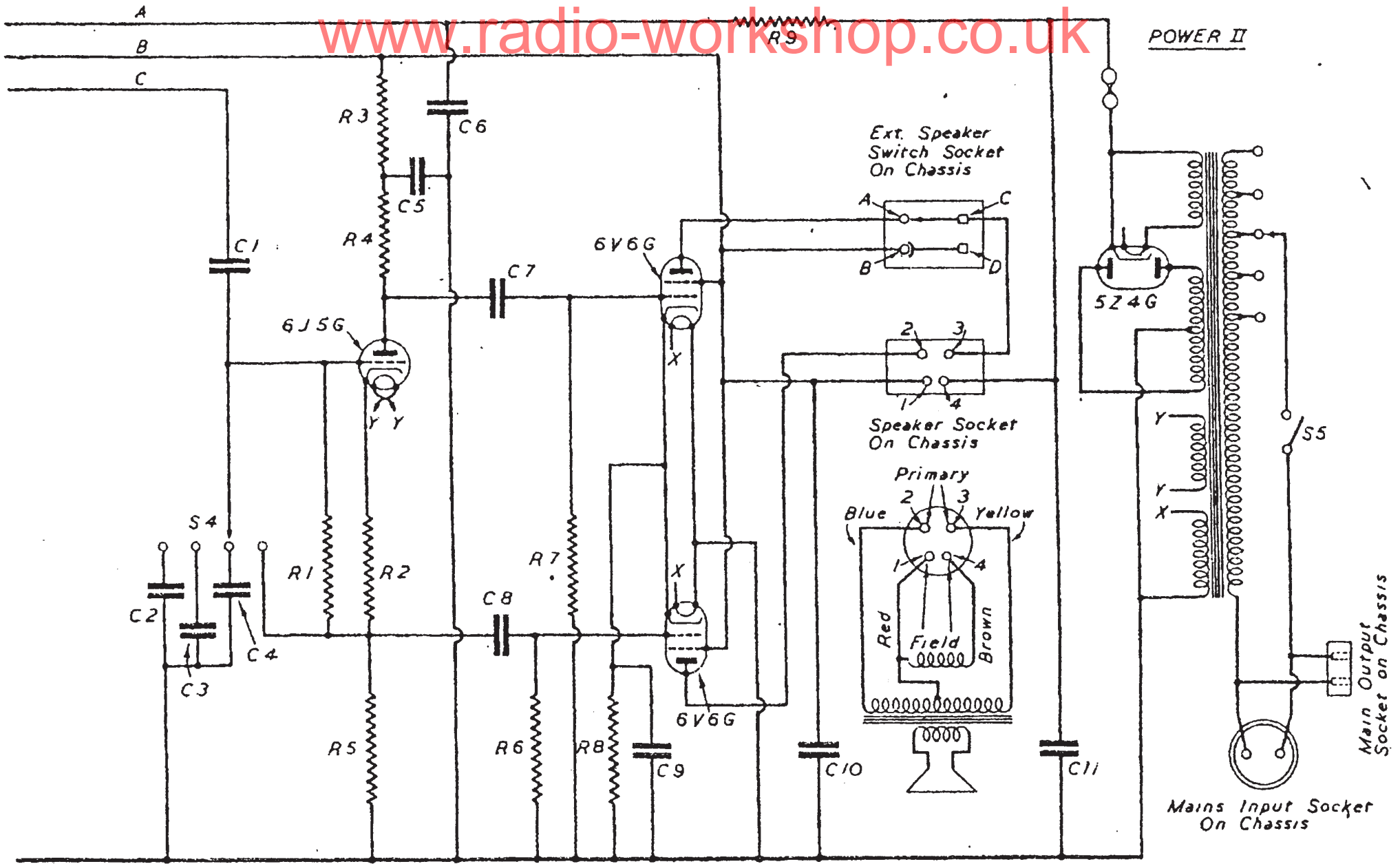

A and B are extension speaker sockets. Extension speaker is connected to plug. C is connected to A and B until plug is completely inserted. When plug is partly inserted both speakers are in operation. When plug is fully inserted A is disconnected from C and D is connected to B, leaving the extension speaker only in operation.

Internal speaker socket viewed from below chassis and plug with pins pointing towards observer.