

www.radio-workshop.co.uk

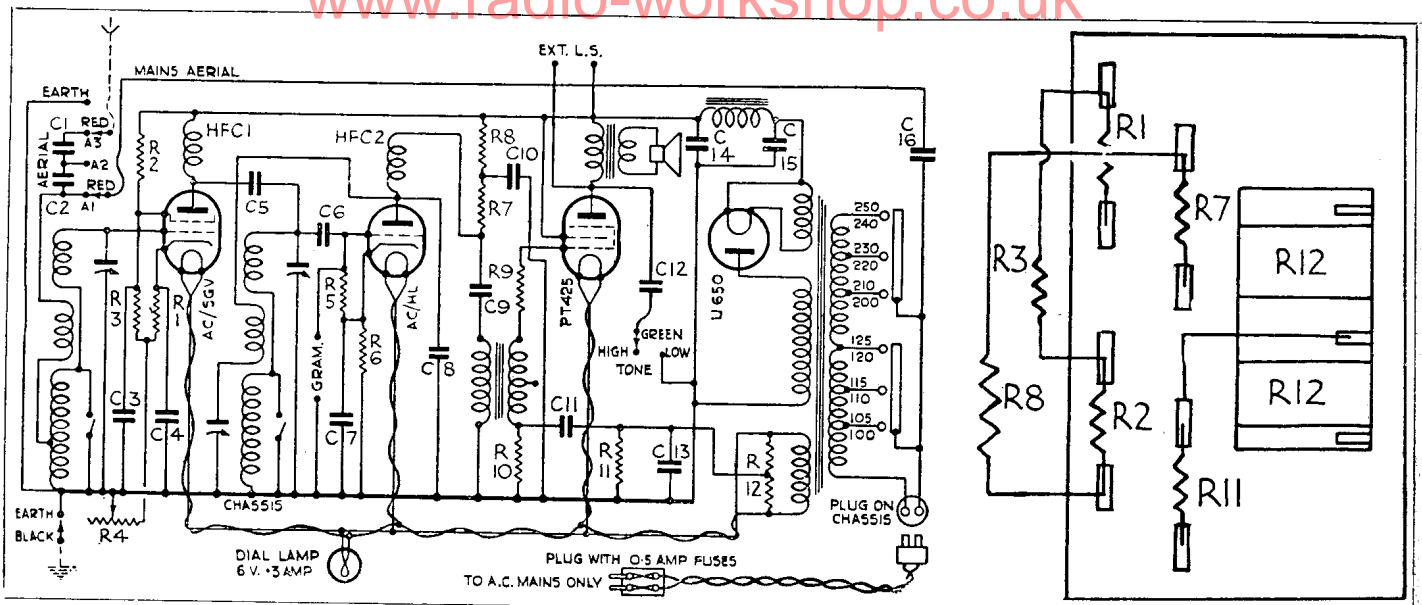

A straight circuit comprising screen-grid, detector and pentode valves is utilised in the Lissen mains "three." On the right are the connections of the spaghetti resistances which may have to be unsoldered when servicing the receiver.

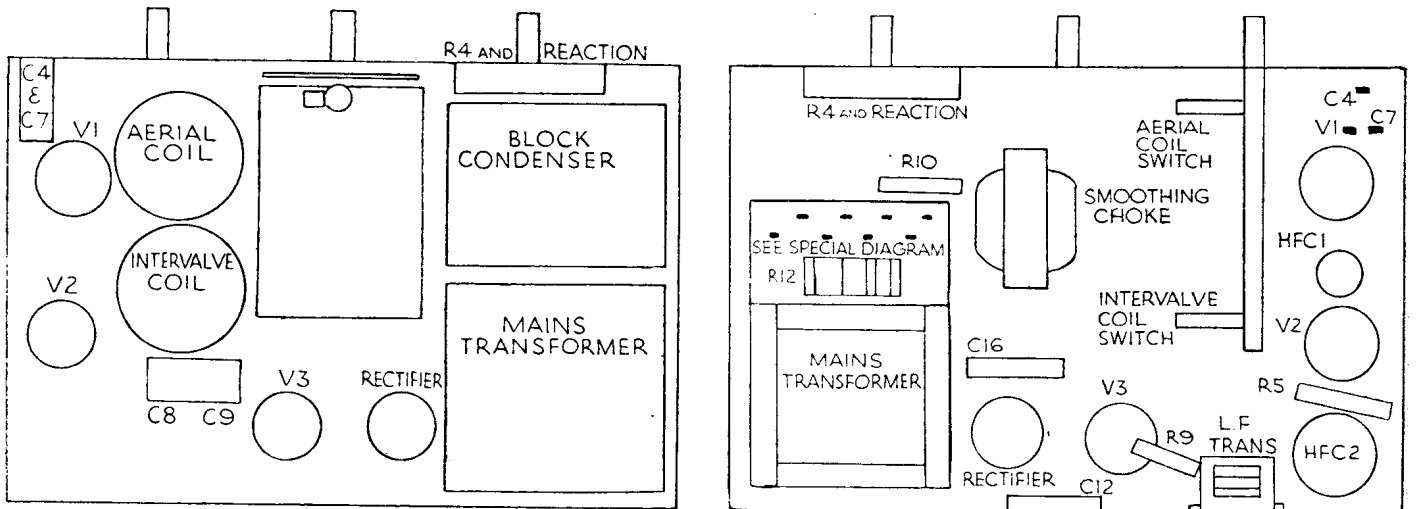

On the top of the Lissen chassis (left) the components are easily recognisable, and the pilot lamp is accessibly mounted. Underneath, the construction is straightforward but for the resistance panel.

## R.G.D. 702 SIX-VALVE RADIOGRAM

**Circuit.**—The H.F. valve VMS4B (V1) is preceded by an aerial transformer with tuned secondary. It is coupled to the first detector by another tuned secondary transformer. The m.a. meter which forms the tuning indicator is included in the anode lead.

A separate oscillator MHL4 (V2) is coupled to the cathode circuit of the first detector.

The first detector VMS4 (V3) works as an anode bend rectifier with cathode bias. It is coupled to the I.F. valve by a band-pass I.F. transformer (I.F. frequency 110 k.c.).

The I.F. valve VMS4 (V4) is biased from a tapping on the A.V.C. potentiometer. It is coupled to the A.V.C. diode by a condenser from the primary of the second band-pass intermediate transformer, while the other diode is fed from the secondary of the I.F. transformer in the conventional way.

The second detector, a double-diode-triode MHD4 (V5) has the triode grid-leak in the form of a variable resistance which acts as volume control. The grid lead includes an

H.F. stopper, R10. In the anode circuit the coupling consists of a resistance in series with a tone correction assembly with C11. A low value of coupling resistance is necessitated and the associated condenser is relatively high C5 of .1 mfd. With R8 at 175,000 ohms as the grid leak of the output valve resistance-capacity coupling ensures a straight line response.

The output valve PP 3/250 (V6) has an anti-parasitic oscillation resistance, R9, in its grid circuit and a tone control across the primary of the output transformer. The speech coils of the two speakers are wired in series.

The mains equipment consists of a transformer and a full wave valve rectifier, UU 120/350, with a very thorough smoothing circuit. In addition to a smoothing choke and associated condensers the 1,000 ohm field coil of the larger speaker is included in the smoothing with an 8 mfd. electrolytic condenser.

The 6,500 ohm field of the small speaker forms a potentiometer across H.T. with the

resistance R4, and provides the screen potential for the H.F. and I.F. valves.

A separate filament winding is provided for the output valve, which provides its own bias. To prevent modulation hum a .01 condenser is connected between one side of the mains and earth.

**Special Notes.**—The circuit of V5 (double-diode-triode) was modified in the instrument we dismantled. We give our version of that part of the set in a different diagram, from which it will be seen that the A.V.C. diode is actually fed from the secondary of the second I.F. transformer, and that, in the circuit to the other diode, the resistances and condensers are connected differently. The values are below the diagram.

In this set the output transformer is inside the chassis, and one end of the speech coil circuit is returned to earth.

The visual indicator is in the form of a m.a. meter in the anode lead to the H.F. valve, and, as the variable volume control (Continued on next page.)

### R.G.D. 702 SIX-VALVE RADIOGRAM (Cont.)

operates on the A.C. output of the diode, the full deflection can be obtained with the V.C. at minimum.

The field of the larger speaker is 1,000 ohms.

**Quick Tests.**—Voltages between the following points and chassis :—

Pin of red wander plug (H.T.+ smoothed by choke) 380 volts.

Pin of blue wander plug (H.T.+ smoothed by choke and 1,000 ohm field) 310 volts.

(Continued on next page.)

#### VALVE READINGS

V.C. max. No signal.

No.	Type.	Purpose.	Elec.	Volts.	M.A.
1	VMS4B	H.F. ...	triode. anode screen	220 60	1.8 —
2	MHL4	ocs. ...	anode	60	2.4
3	VMS4	1st det. ...	anode screen	220 60	1.7 —
4	VMS4B	1F. ...	anode screen	220 60	1.5 —
5	MHD4	det. & L.F. ...	Triode anode	290	3.5
6	PP3/250	output	anode	290	34

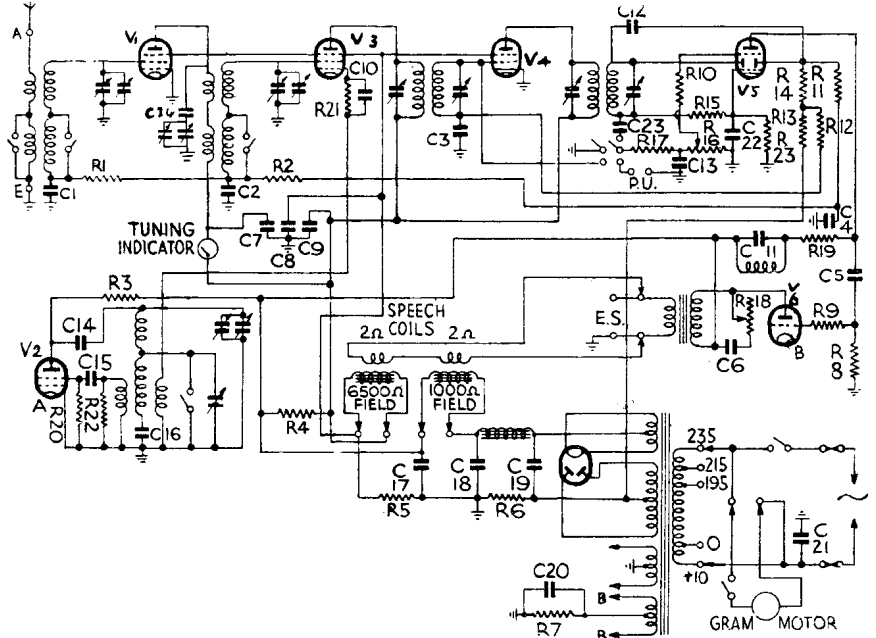

Above is the standard circuit of the Radio Gramophone Development Co.'s 702 instrument. Separate oscillator, diode detection, R.C.C. coupling and tone correction are features. Below are the plans of the chassis.

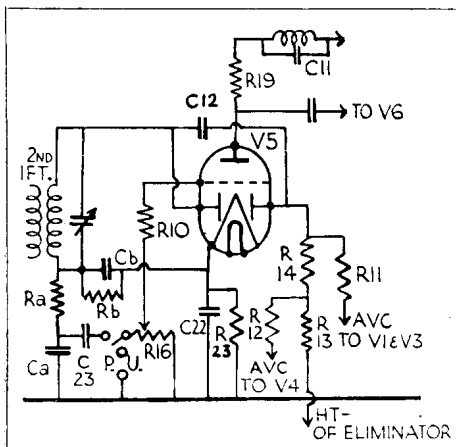
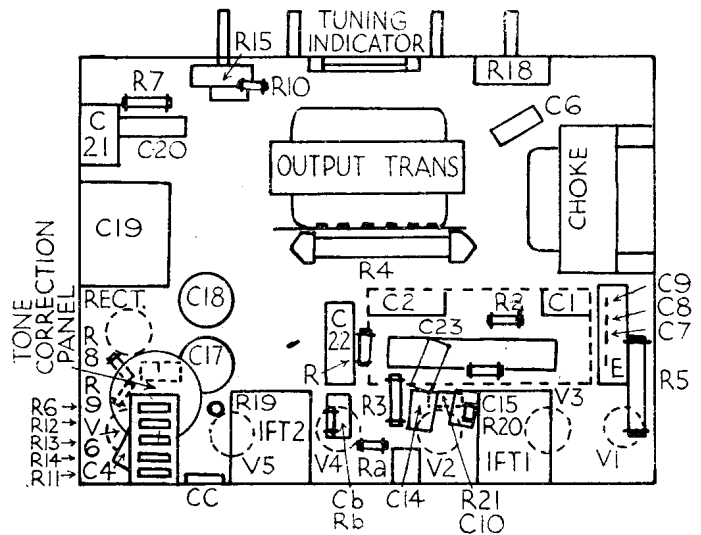
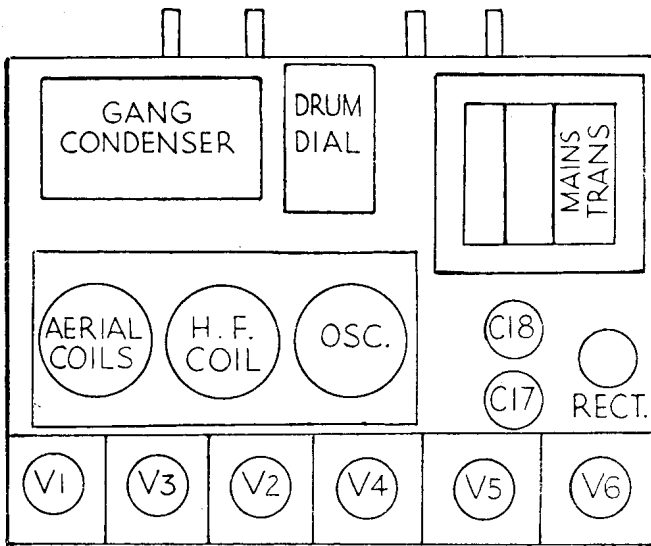

In some models of the R.C.D. 702 the diode connections are as above, and not as shown in the standard circuit.

#### CONDENSERS

C.	Purpose.	μFD.
1	Decoupling AVC to V1...	.1
2	Decoupling AVC to V3...	.1
3	Decoupling AVC to V4...	.1
4	Decoupling AVC to V1, V3	.1
5	L.F. coupling V5 to V6	.1
6	Part of tone control circuit	.1
7	Decoupling meter	.2
8	Decoupling grids V1, V3 and V4 in one unit	.2
9	Decoupling anodes V3 and V4	.2
10	Cathode V3	.002
11	Tone correction circuit anode V4	.002
12	Feed to AVC diode anode	.0001
13	H.F. by-pass	.0001
14	Reaction condenser anode V2	.0001
15	V2 grid condenser	.001
16	Low potential end osc. coil	.005
17	Smoothing condenser	8
18	Smoothing condenser	7
19	Smoothing condenser	4
20	Across bias resistance V6	20
21	Mains by-pass	.01
22	Cathode V5 (electro.)	50
23	Low potential end of S. of 2nd I.F.T.	.04
a	Decoupling IFT2 secondary	.0001
b	Grid cathode return	.0001

#### RESISTANCES

R.	Purpose.	Ohms.
1	Decoupling AVC to V1...	100,000
2	Decoupling AVC to V1 and V3...	100,000
3	V2 anode stopper	100,000
4	Part of H.T. ptr. with L.S. field	2,500
5	Part of H.T. ptr. with L.S. field	2,500
6	In H.T.—lead provides delay in AVC	30
7	Bias resistor V6	1,000
8	V6 grid leak	175,000
9	H.F. stopper grid V6	20,000
10	H.F. stopper grid V5	20,000
11	Decoupling delay bias	.25 meg.
12	Decoupling AVC to V4...	.25 meg.
13	Part of AVC ptr.	.25 meg.
14	Part of AVC ptr.	.5 meg.
15	See special notes	.5 meg.
16	Var. volume control across diode output	.5 meg.
17	Decoupling grid V5	50,000
18	Part of tone control circuit anode V6	25,000
19	L.F. coupling V5, V6	25,000
20	Grid V2	10,000
21	Cathode V3	2,000
22	Across osc. grid coil	1,000
23	Cathode V5	500
a	Low v. end of I.F.T.2	500,000
b	Cathode return	50,000

www.radio-workshop.co.uk

### R.G.D. 702 RADIOGRAM (Contd.)

Pin of purple wander plug 245 volts (junction of R.14 and 6,500 ohm field of smaller speaker).

Voltagages at S.G. anodes are given on valve table.

Remember, the second valve from the right (looking from back) is a double diode triode with grid terminal at the top.

**Removing the Chassis.**—There is no need to remove the control knobs.

Remove the coded L.S. field plugs, the motor plug, the pick-up plugs (green), and the L.S. plugs (black).

Remove two wood screws holding the panel to the front of the cabinet (seen under gramophone motor).

Undo two bolts holding the rear flange of the chassis to strut.

Release two clamps holding the front by slackening the butterfly nuts. Lift chassis out.

When the output valve has been removed the chassis can stand on the mains transformer end.

**General Notes.**—With the help of the lay-out diagram the circuit can quite easily be followed, and with the exception of R21 and C10, C1 and C2, all the components are accessible. If the meter, tone control or volume control have to be replaced, remove

the knobs and the four bolts holding the panel to the chassis (remember the distance pieces when replacing) and the fixing nuts can be undone.

If the switch contacts require cleaning, turn the spindle so that the moving contacts are to the rear, when they can be reached with a piece of cloth wrapped round a screw-driver.

To clean the springs, turn the contacts away from them and slip a thin piece of tape underneath and clean by sliding the tape under the springs, taking care that these are not strained outwards.

When making tests on mains sets employing double diode triodes, touching the grid terminal of that valve should produce an increase of hum in the speaker which, in this case, is more noticeable with the V.C. at maximum.

Failure to obtain hum indicates that either the D.D.T. valve or the output valve or their circuits is defective.

**Replacing the Chassis.**—Have the bolts that hold the back of the chassis ready to hand and after laying the chassis on the supports slip them through the holes.

Replace the two wood screws holding the panel to the front of the cabinet and screw the nuts on to the bolts, remembering to fix the motor earth under one of them.

Replace the L.S. field plugs, the pick-up plugs, the motor plug and the speech coil plugs. The latter are correct when they are in line horizontally.

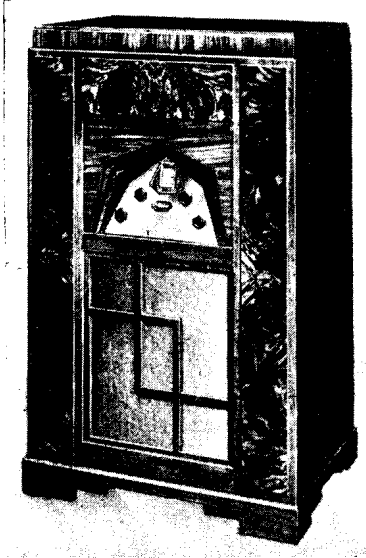

The Radio Gramophone Development Co.'s 702 is available either with or without a Garrard automatic record changer. The circuit is designed for a good radio performance allied with high quality. Behind the large fret of the distinctive and modern cabinet is a pair of dual reproducers.

## "SWAN" STRAIGHT MAINS THREE BY AERODYNE RADIO

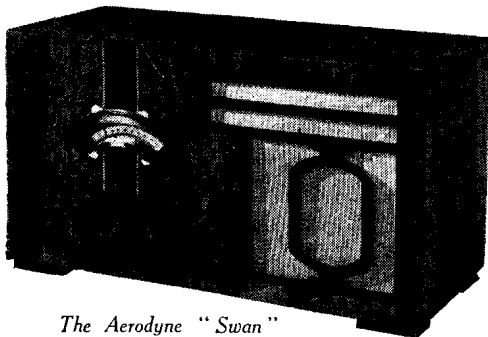

The Aerodyne "Swan"

**Circuit.**—The H.F. valve (V1) VP4, a variable-mu H.F. pentode, is preceded by a band-pass aerial circuit and the volume is controlled by the conventional variable resistance in the cathode lead. Coupling to the next valve is by tuned anode.

The detector valve (V2), 354V, is a proper power grid detector, with .0001 mfd condenser (C11), and ¼ megohm leak R7. Reaction is applied to the tuned anode coil and an H.F. filter is included in the anode circuit. Filtered transformer coupling includes R8 and C15.

The output valve (V3), a seven-pin pentode, Pen 4 VA, is compensated by a simple condenser, C16, across the output transformer primary.

Full wave rectification is used and the rectifier is of the indirectly heated type, DW3. The L.S. field is used for smoothing in the H.T.+ lead, and the associated condensers are 6 mfd. electrolytics.

**Quick Tests.**—Voltagages from terminals on L.S. transformer :

- Right hand (1) (H.T. unsmoothed)... 370V.
- (2) (V4 anode) ..... 240V.
- (3 and 4) (H.T. smoothed) 255V.
- S.G. anode, V.C. max.... 220V.

**Removing Chassis.**—Undo knobs (grub screws). Undo two clips holding speaker leads. Remove four screws from underneath.

(One is hidden under the felt on the rear support.)

Lift chassis out (leads to L.S. need not be disconnected).

**General Notes.**—The wiring from the mains transformer is coded :—

- Black and yellow—set filaments.
- Red and yellow—rectifier filaments.
- Red—rectifier anodes.
- Pink and green—centre taps (earthed).
- Brown—lowest mains tapping.
- Green—middle mains tapping.

- Blue—highest mains tapping.
- Yellow—switch (i.e., mains O.).

**Cleaning Switch.**—Remove two screws holding resistance panel.

Unsolder the following leads :—

- R3 to volume control.
- R9 to electrolytic condenser C18.
- R1 to switch (underneath).

Ease the resistance panel upwards and the switch can be reached.

**Replacing Chassis.**—Lay chassis loosely in cabinet and manoeuvre the rear corner screw into position.

Replace remaining screws.

Replace clips holding speaker leads

Replace knobs—noting the correct position of the "Off" on the V.C. knob. In our model the grub screw was opposite the rounded side of the spindle.

See next page for diagrams.

### VALVE READINGS

Valve.	V.C. max.		
	Connection.	Volts.	M.A.
V1 VP4	anode	220	3.5
	screen	105	—
V2 354V	anode	150	3
V3 Pen.4VA	anode	240	30
	aux. grid	255	5.
DW3	each anode	340A.C.	—

## R.M.A. Colour Code for Resistors

Under the colour code for resistances standardised among members of the R.M.A. : The colour on the body of a resistance signi-

fies the first figure of its value, the colour on the end gives the second figure, and the spot in the middle indicates the number of ciphers which follow the first two figures.

The absence of a different colour at either the end or "spot," denotes that the figure is the same as that of the body colour.

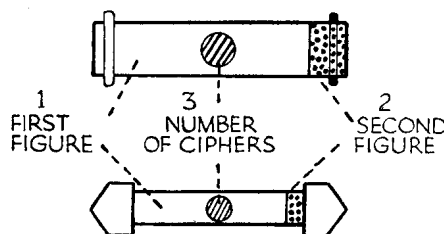

### Colour Markings.

- |        |         |        |         |
|--------|---------|--------|---------|
| Black  | ..... 0 | Green  | ..... 5 |
| Brown  | ..... 1 | Blue   | ..... 6 |
| Red    | ..... 2 | Violet | ..... 7 |
| Orange | ..... 3 | Grey   | ..... 8 |
| Yellow | ..... 4 | White  | ..... 9 |

**Examples.**—Brown body, black end, red spot = 1000 ohms; yellow body, green end, no spot = 450,000 ohms; orange body, grey end, black spot = 38 ohms.

The figures giving the resistance value are read in the order indicated by the numbers.