

ROBERTS R77

portable radio receiver

THE R77 is a 4-valve 2-band battery superhet receiver incorporating a printed circuit chassis, self-contained Ferrite rod aerial, and fitted in a coach-hide zip-fastened case. It covers 190-570m medium-wave and 1,000-1,900m long-wave.

CIRCUIT DETAILS

A DK96 is used as a heptode frequency changer. The mixer tuned circuit consists of L1 and L2, C3 and trimmer C2 for long-wave (with C1 fixed capacitor). On medium-wave, L2 is shorted out and C1, C2 taken out of circuit. The m.w. trimmer is C4.

A single m.w. and l.w. oscillator transformer is used (L5, L6), with C10 for m.w. trimming and C9 with C8 for l.w. trimming. On m.w. operation a damping resistor R3 is brought into circuit across the oscillator tuned grid circuit.

The i.f. output is fed via i.f. transformer T1 to the signal grid of the second valve, a DF96 functioning as a conventional i.f. amplifier, the output of which is coupled via T2 to the diode anode of the DAF96.

The d.c. component developed across the diode load R7 is fed back as a.g.c. bias to the i.f. amplifier and mixer. The audio signal across the volume control is coupled via C19 to the grid of the DAF96 pentode section where, after amplification, it is fed to the DL96 output valve.

The grid bias for this stage is obtained by the voltage drop across R12 in the

h.t. negative line. The wavechange switching in the circuit diagram is shown in the long-wave position; the centre position is "off" and the other used position is medium-wave.

SERVICING NOTES

When removing or inserting a component on the printed circuit wiring, care must be taken to avoid excessive pressure as the copper may separate from the base material.

To prevent corrosion, the wiring has been protected by a thin coat of wax. For soldering, an iron with a small

RELEASE DATE AND PRICE

May, 1957. 18 gns. tax paid.
Batteries 11s. 6d. extra.

diameter bit, not exceeding 30 watts, should be used. The iron should be applied to the joint only long enough to cause the solder to flow, and then be quickly removed.



SERVICE SNAPS

ROBERTS R77

Valves: One each DK96 (f.c.), DF96 (i.f.), DAF96 (det., a.g.c., audio) and DL96 (output).

Volume Control: 500kΩ.

Electrolytic: 8μF, 100V.

Intermediate Frequency: 470 kc/s.

Power Supply: H.t.—90V; L.t.—1.5V (Ever Ready B126 and AD35).

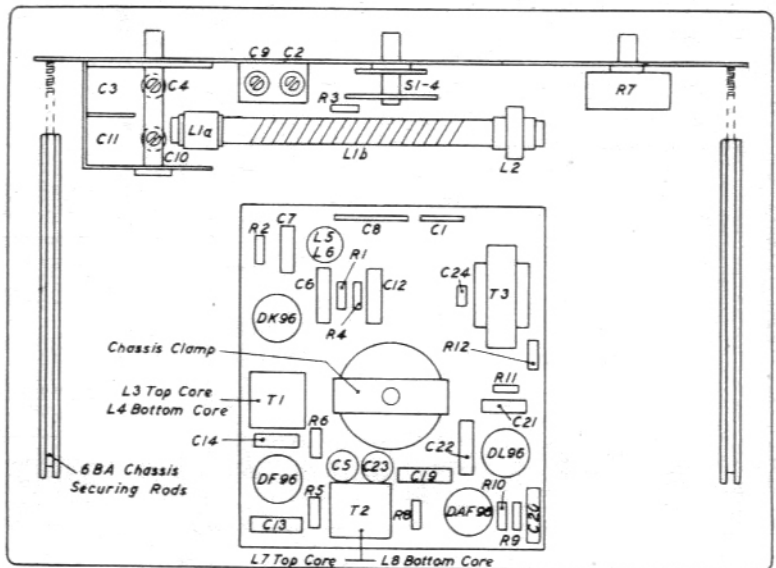

Control panel and circuit board layout showing positions of main components.

Radiospares

QUALITY · RANGE · SERVICE

FOR
all your Component needs

Circuit diagram of the Roberts R77 portable radio

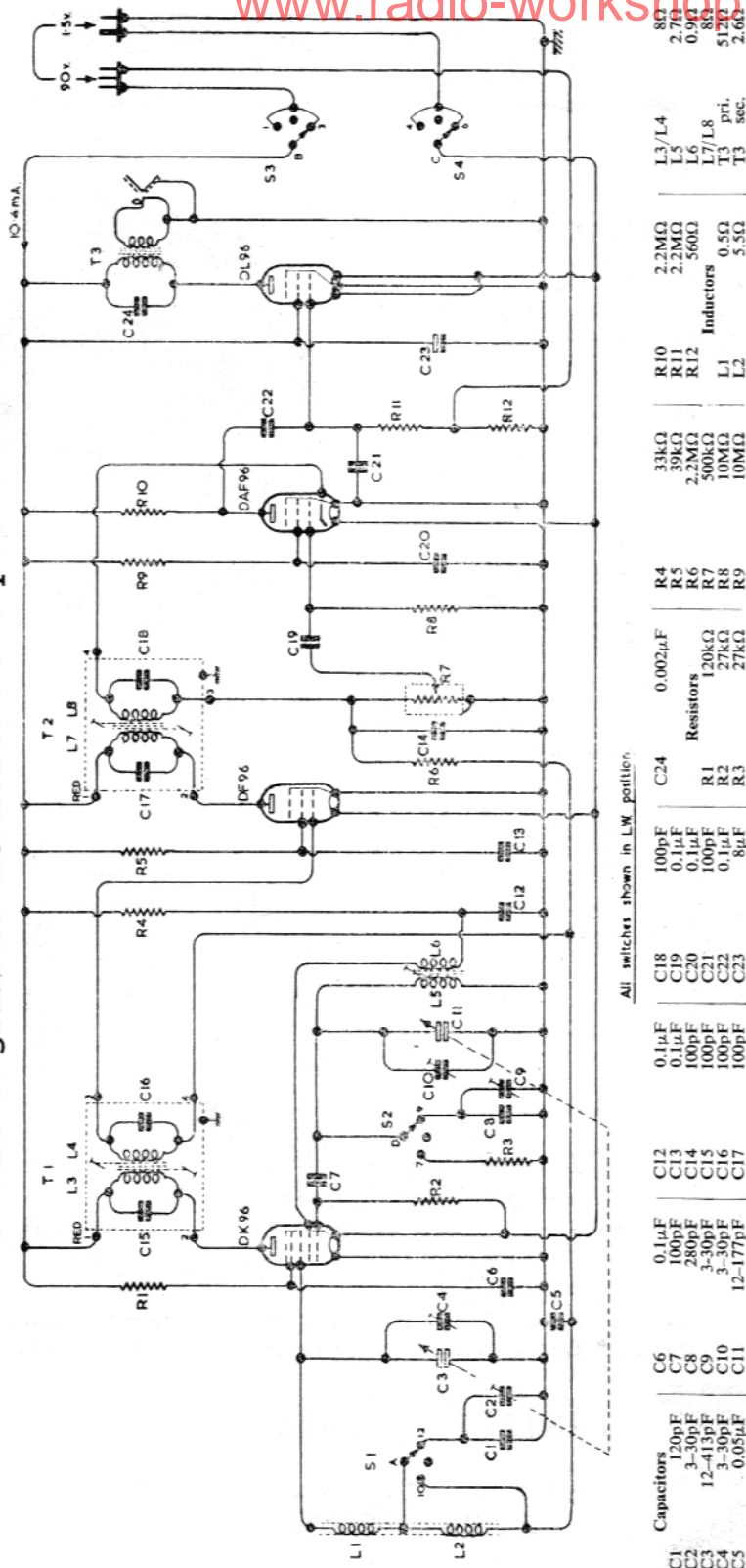

All switches shown in L.W. position.

- | | | | | | | | |
|------------|-----|----------|-----|---------|-----------|-------|-------|
| Capacitors | C6 | 0.1μF | C12 | 100pF | Inductors | L1 | 5.5Ω |
| | C7 | 100pF | C13 | 0.1μF | | L2 | 2.2MΩ |
| | C8 | 100pF | C14 | 0.1μF | | L3/L4 | 2.2MΩ |
| | C9 | 280pF | C15 | 100pF | | L5 | 2.7Ω |
| | C10 | 3-30pF | C16 | 100pF | | L6 | 0.9Ω |
| | C11 | 3-30pF | C17 | 100pF | | L7/L8 | 8Ω |
| | C1 | 0.05μF | C18 | 0.002μF | | T3 | 512Ω |
| | C2 | 120pF | C19 | 100pF | Resistors | T3 | 2.6Ω |
| | C3 | 3-30pF | C20 | 0.1μF | | | |
| | C4 | 12-177pF | C21 | 100pF | | | |
| | C5 | | C22 | 8pF | | | |
| | | | C23 | | | | |
| | | | C24 | | | | |

Alignment Procedure

All trimming adjustments are made for maximum output as indicated on standard output indicator. The various adjustments should be repeated until no further improvement in output (or calibration) can be obtained.

I.F.: Inject signal of 470 kc/s and adjust L8, L7, L4 and L3, in that order.

M.W.: With the gang fully meshed, check that the medium-wave datum line on the tuning scale coincides with the index marker on the panel. Tune receiver to 500m, inject signal of 600 kc/s and adjust L5/6 core and then L1.

Retune receiver to 200m and signal generator to 1,500 kc/s and adjust C10 and then C4.

L.W.: Tune receiver to 1224m (Kalundborg), inject signal of 245 kc/s and adjust C9 and then C2. Retune receiver to 1,829m (Allouis), inject signal of 164 kc/s and adjust L2.

Note.—For i.f. alignment, signal generator may be connected between stator of C3 and chassis. For r.f. alignment signal generator output should be loosely coupled to the input circuit by securing the leads close to the Ferrite rod aerial.

DISMANTLING

To remove the chassis, lay the receiver on its back and unzip the case bottom. Remove the two batteries and, with a box spanner, screwdriver or small coin, unscrew the two 6BA chassis-securing rods shown in the layout drawing. Remove the two fibre battery containers and withdraw the chassis from the top of the case.

To obtain access to the underside of the printed circuit board proceed as follows:

Lay the chassis, speaker downwards, on a clean flat surface. Using great care, remove the Ferrite rod aerial from the chassis. Slacken the four speaker-securing nuts with a 6BA flat spanner and remove the 4BA dome nut, serrated washer and chassis clamp.

Then lift the printed circuit board gently by its rear edge over the speaker shroud.

To re-assemble use the reverse order, ensuring that the printed circuit board is pushed hard up against the chassis front plate before finally tightening the speaker nuts.

VALVE VOLTAGES			
Valve	Function	Anode	Screen
DK96	Freq. Changer	86	76 (G4)*
DF96	I.F. Amplifier	86	65
DAF96	A.F. Amplifier	34	16
DL96	Output	84	86

* G2 (oscillator anode), 30V.
Total h.t. consumption—10.4mA.
Above readings obtained on an electronic testmeter.