

NUMBER 148

'TRADER' SERVICE SHEETS

www.radio-workshop.co.uk

ULTRA 101

(AND 96 RADIO-GRAMPHONE)

THE Ultra 101 table receiver employs a 3-valve (plus rectifier) A.C. superhet chassis with a triode-pentode frequency changer, a variable-mu pentode I.F. amplifier, and a double diode output pentode. A similar chassis is fitted in the 96 radio-gramophone, but there are certain modifications for pick-up working, and these are explained in the General Notes section.

CIRCUIT DESCRIPTION

Aerial input via coupling coils **L1, L2** to inductively coupled band-pass filter. Primary **L3, L4** tuned by **C16**; secondary **L6, L7** tuned by **C18**.

First valve is a triode-pentode (**V1, Mazda metallised AC/TP**) operating as frequency changer with cathode injection. Triode section forms separate oscillator with anode coils **L10, L11** tuned by **C21** and coupling coils **L8, L9** in common cathode circuit. Trimming by **C22**

(M.W.) and **C20** (L.W.); tracking by shaped condenser plates and additional fixed condenser **C6** (L.W.).

Second valve, a variable-mu H.F. pentode (**V2, Mazda metallised AC/VP1**) operates as intermediate frequency amplifier with tuned-primary tuned-secondary transformer couplings **C23, L12, L13, C24** and **C25, L14, L15, C26**.

Intermediate frequency 456 KC/S.

Diode second detector is part of double diode output pentode (**V3, Mazda AC2/PenDD**). Audio-frequency component in rectified output is developed across load resistance **R9** and passed via coupling condenser **C9, I.F. stopper R11, manual volume control R12** and I.F. stopper **R10** to control grid of pentode section. Tone correction in anode circuit by fixed condenser **C13**. Provision for connection of external low-impedance speaker across secondary of output

transformer **T1**. Plug and socket enable internal speaker speech coil circuit to be broken.

Second diode of **V3**, fed from **V2** anode via condenser **C12**, provides D.C. potential which is developed across load resistances **R16, R17** and fed back through decoupling circuits as G.B. to F.C. and I.F. valves, giving automatic volume control. Delay voltage is obtained from drop along **V3** cathode resistances **R13, R14**.

H.T. current is supplied by I.H.C. full-wave rectifying valve (**V4, Mazda UU3**). Smoothing by speaker field coil **L18** and aqueous electrolytic condensers **C14, C15**.

COMPONENTS AND VALUES

RESISTANCES		Values (ohms)
R1	V1 pentode C.G. decoupling ..	1,000,000
R2	V1 pentode anode decoupling ..	7,000
R3	V1 osc. harmonic suppressor ..	1,000
R4	V1 osc. C.G. resistance ..	50,000
R5	V1 cathode resistance ..	480
R6	V1 osc. anode decoupling ..	80,000
R7	V2 C.G. decoupling ..	1,000,000
R8	V2 fixed G.B. resistance ..	30
R9	V3 signal diode load ..	500,000
R10	V3 C.G. I.F. stopper ..	1,000
R11	I.F. stopper ..	10,000
R12	Manual volume control ..	1,000,000
R13	V3 G.B. and A.V.C. line delay ..	138
R14	voltage resistances ..	138
R15	V3 pentode anode stabiliser ..	60
R16	V3 A.V.C. diode load ..	250,000
R17		750,000

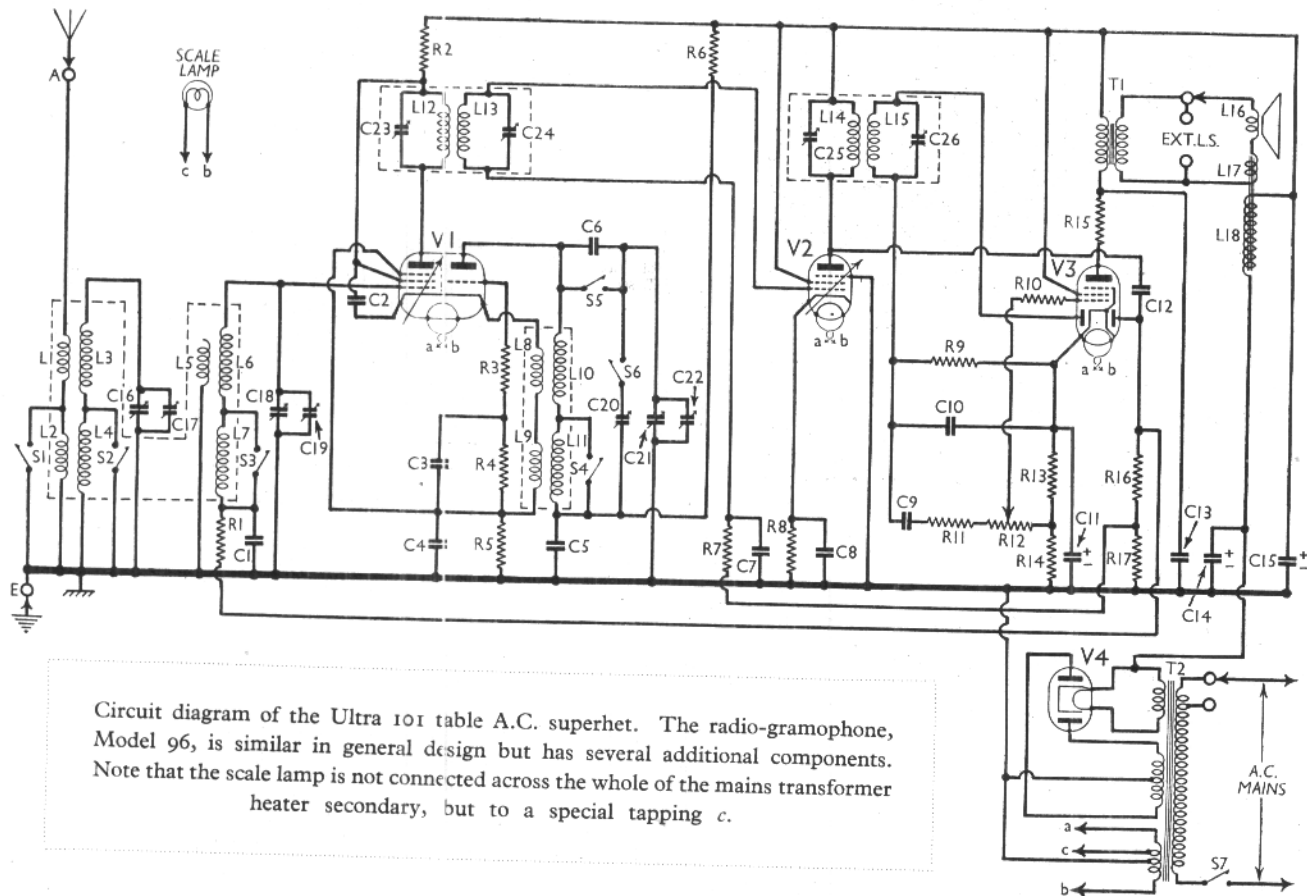

Circuit diagram of the Ultra 101 table A.C. superhet. The radio-gramophone, Model 96, is similar in general design but has several additional components. Note that the scale lamp is not connected across the whole of the mains transformer heater secondary, but to a special tapping c.

Under-chassis view. The screening cover over the switch and coil assembly has been removed in order to show clearly the positions of the wavechange switches, the signal frequency coils, and condensers C1 and C6. Components R10, R9, C9 and C11 are mounted one above the other in that order on a vertical paxolin panel.

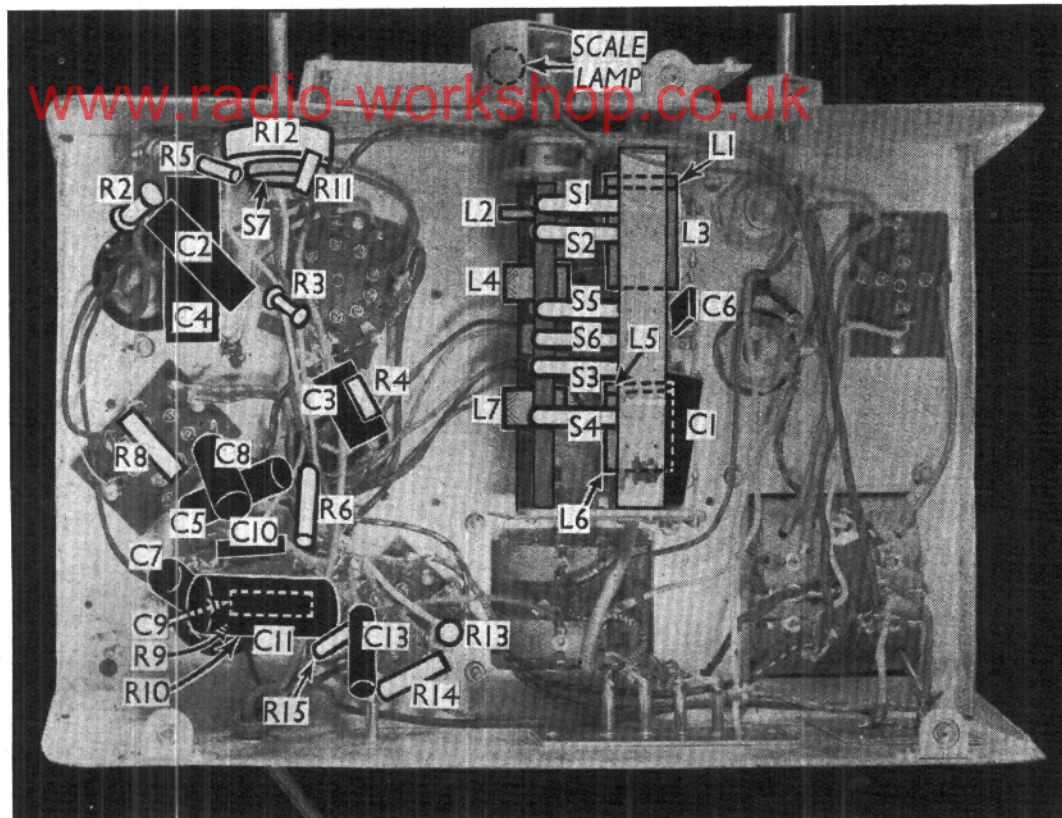

CONDENSERS		Values (μF)
C1	V1 pentode C.G. decoupling ..	0.05
C2	V1 pentode S.G. and anode decoupling ..	0.1
C3	V1 osc. C.G. condenser ..	0.0002
C4	V1 cathode by-pass ..	0.5
C5	V1 osc. anode decoupling ..	0.1
C6	Oscillator L.W. tracker ..	0.0003
C7	V2 C.G. decoupling ..	0.05
C8	V2 cathode by-pass ..	0.1
C9	L.F. coupling to V3 pentode ..	0.01
C10	I.F. by-pass ..	0.0002
C11*	V3 cathode by-pass ..	50.0
C12	Coupling to V3 A.V.C. diode ..	0.0002
C13	Fixed tone corrector ..	0.01
C14*	H.T. smoothing ..	8.0
C15*	H.T. smoothing ..	16.0
C16†	Band-pass primary tuning ..	—
C17‡	Band-pass primary trimmer ..	—
C18†	Band-pass secondary tuning ..	—
C19‡	Band-pass secondary trimmer ..	—
C20†	Oscillator L.W. trimmer ..	—
C21†	Oscillator circuit tuning ..	—
C22†	Oscillator M.W. trimmer ..	—
C23‡	1st I.F. trans. pri. tuning ..	—
C24‡	1st I.F. trans. sec. tuning ..	—
C25‡	2nd I.F. trans. pri tuning ..	—
C26‡	2nd I.F. trans. sec. tuning ..	—

* Electrolytic. † Variable. ‡ Pre-set.

OTHER COMPONENTS		Approx. Values (ohms)
L1	Aerial coupling coils ..	1.5
L2	—	48.5
L3	—	4.7
L4	Band-pass primary coils ..	11.3
L5	L.6 loading coil ..	1.3
L6	—	4.7
L7	Band-pass secondary coils ..	11.3
L8	—	1.2
L9	Oscillator coupling coils, total ..	8.5
L10	—	8.5
L11	Oscillator tuning coils ..	8.5

OTHER COMPONENTS (Continued)			Approx. Values (ohms)
L12	1st I.F. trans. Pri. ..	4.2	
L13	— Sec. ..	4.2	
L14	2nd I.F. trans. Pri. ..	4.2	
L15	— Sec. ..	4.2	
L16	Speaker speech coil ..	2.2	
L17	Hum neutralising coil ..	0.1	
L18	Speaker field coil ..	1500.0	
T1	Output trans. Pri. ..	375.0	
	— Sec. ..	0.18	
	— Pri. total ..	28.0	
T2	Mains trans. Heater sec. ..	0.1	
	— Rect. heat. sec. ..	0.15	
	— H.T. sec. total ..	580.0	
S1-S6	Waveband switches ..	—	
S7	Mains switch, ganged R12 ..	—	

DISMANTLING THE SET

A detachable bottom is fitted to the cabinet, and this, when removed (four wood screws), gives easy access to most of the under-chassis components.

Removing Chassis.—Remove the three control knobs from their spindles (recessed grub screws). Remove the three bolts (with spiked washers) from the underside of the cabinet, and the chassis can be withdrawn to the extent of the speaker leads for most repairs.

Removing Speaker.—Three metal clamps hold the speaker to a sub-baffle, and removal of these (large nuts) will enable the chassis to be taken from the cabinet. When replacing, the soldering tag strip should be at the left (looking from the rear) and if the wires have been removed they should be replaced as follows, numbering the tags from top to bottom: —1, Black; 2, Blank; 3, Green; 4, Yellow; 5, Red.

VALVE ANALYSIS

Valve voltages and currents listed in the table below were obtained from an average chassis operating with a 230 V 50 c.p.s. mains supply (230-250 mains transformer tap). There was no signal input (aerial and earth sockets S/C), and the receiver controls were set as follows: — wavechange switch at M.W.; gang condenser at minimum capacity; volume control at maximum.

All voltages were measured on the 1,200 V scale of an Avometer, chassis being negative.

Valve	Anode Voltage (V)	Anode Current (mA)	Screen Voltage (V)	Screen Current (mA)
V1 AC/TP*	170	6.7	170	2.3
V2 AC/VP1	240	14.5	240	4.1
V3 AC/2/- PenDD	225	30.0	240	6.5
V4 UU3 ..	310†	—	—	—

* Triode osc. anode 65V 2.0 mA. † Each anode A.C.

GENERAL NOTES

Switches.—S1-S6 are the waveband switches in a single ganged unit beneath the chassis. The screening cover over this and the signal-frequency coils has been removed in our under-chassis view. All switches, except S6, are closed on the M.W. and open on the L.W. band. S6 is closed on L.W. and open on M.W.

S7 is the Q.M.B. mains switch, ganged with the volume control R12.

Coils.—L1-L7, the signal-frequency coils, are mounted beneath the chassis between the switch unit and the chassis deck. A

(Continued overleaf)

ULTRA 101 (and 96) (Continued).

screening cover fits over the whole assembly. Note that **L1** and **L5** are wound over **L3** and **L6** respectively.

L8-L11, the oscillator coils, are in a screened unit on the chassis deck together with the trimming condenser **C20**.

The I.F. transformers **C23**, **L12**, **L13**, **C24** and **C25**, **L14**, **L15**, **C26** are in two further screened units on the chassis deck. The second unit also contains **R1**, **R7**, **R16**, **R17** and **C12**.

Condensers.—**C14**, **C15** are two aqueous electrolytics in cylindrical metal cases mounted on the chassis deck. **C14** has a rated capacity of $8\mu\text{F}$ and **C15** $16\mu\text{F}$. The container of each is the negative connection.

C11 is a tubular $50\mu\text{F}$ 12 V dry electrolytic condenser mounted underneath the chassis.

Components C11, C9, R9, R10.—These are mounted on a vertical paxolin panel underneath the chassis. As their positions may not be quite clear in the under-chassis illustration, it should be noted that the large tubular electrolytic condenser **C11** is at the top, then come **C9**, **R9** and **R10**, in that order.

Components R1, R7, R16, R17, C12.—These are all inside the second I.F. transformer unit, and the resistances can be identified by their colour coding. Both **R1** and **R7** are 1 MO resistances, and of the two, **R1** is mounted vertically and **R7** horizontally.

Scale Lamp.—This is an Osram M.E.S. type rated at 4.5 V 0.3 A. Note that it is connected across a part of the mains

transformer heater winding by means of a second tapping.

External Speaker.—Provision is made for the connection of a low impedance external speaker (about 10 Ω) across the secondary of the output transformer **T1**. An Ultra 30 (chassis model) or Ultra 45 (cabinet model) is recommended. A plug and socket arrangement enables the internal speaker speech coil circuit to be broken.

RADIOGRAM MODIFICATIONS

In the 96 radiogram chassis there are four fixed condensers, two fixed resistances and two switches additional to those shown in the 101 circuit diagram and chassis pictures. The pick-up feeds into the I.F. amplifier valve **V2**, which, on gramophone, operates as a triode L.F. amplifier R.C. coupled to the output pentode **V3**.

The pick-up winding, by-passed with a $0.0002\mu\text{F}$ condenser, is connected permanently in the **V2** A.V.C. line in series with the decoupling resistance **R7** and the secondary of the first I.F. transformer. **V2** screening grid is used as the triode anode, and has a 7,000 Ω load resistance and a 15,000 Ω decoupling resistance working in conjunction with a $2.0\mu\text{F}$ by-pass condenser. A $0.1\mu\text{F}$ condenser couples the S.G. via change-over switches to the manual volume control **R12** in **V3** control grid circuit, and a further $0.002\mu\text{F}$ condenser is used as an anode-chassis by-pass.

CIRCUIT ALIGNMENT

I.F. Transformers.—Feed in a 456 KC/S signal to the control grid of **V1** pentode section (top cap), and adjust trimmers **C26**, **C25**, **C24** and **C23** for maximum

'RADIO MAINTENANCE' REPRINTS

Subscribers to reprints of the "Radio Maintenance" feature have copies of each week's sheets posted direct to them a few days after publication in the Journal. A strong clip-back binder is also supplied in which they can be inserted. By this means service information is always current, always available and always reliable. The subscription to 26 separate issues of "Radio Maintenance" incorporating 52 Service Sheets, including strong clip-back binder, is 10/6, post free. Binder only, 2/-, post free.

output. Keep input low in order to avoid A.V.C. action.

Signal-frequency and Oscillator Circuits.—First of all adjust the scale pointer to cover the horizontal line above 2,000 m. with the gang condenser at maximum.

With the wavechange switch set to M.W. and the gang condenser to 200 m. feed in a 200 m. signal to the aerial and earth sockets. Adjust trimmers **C22**, **C17** and **C19**, in that order, for maximum output. If a heterodyne whistle is noticed just above the London Regional station re-trim **C17** and **C22** until it disappears.

Set wavechange switch to L.W. and gang condenser to 1,500 m. Feed in a 1,500 m. signal and adjust **C20** for maximum output.

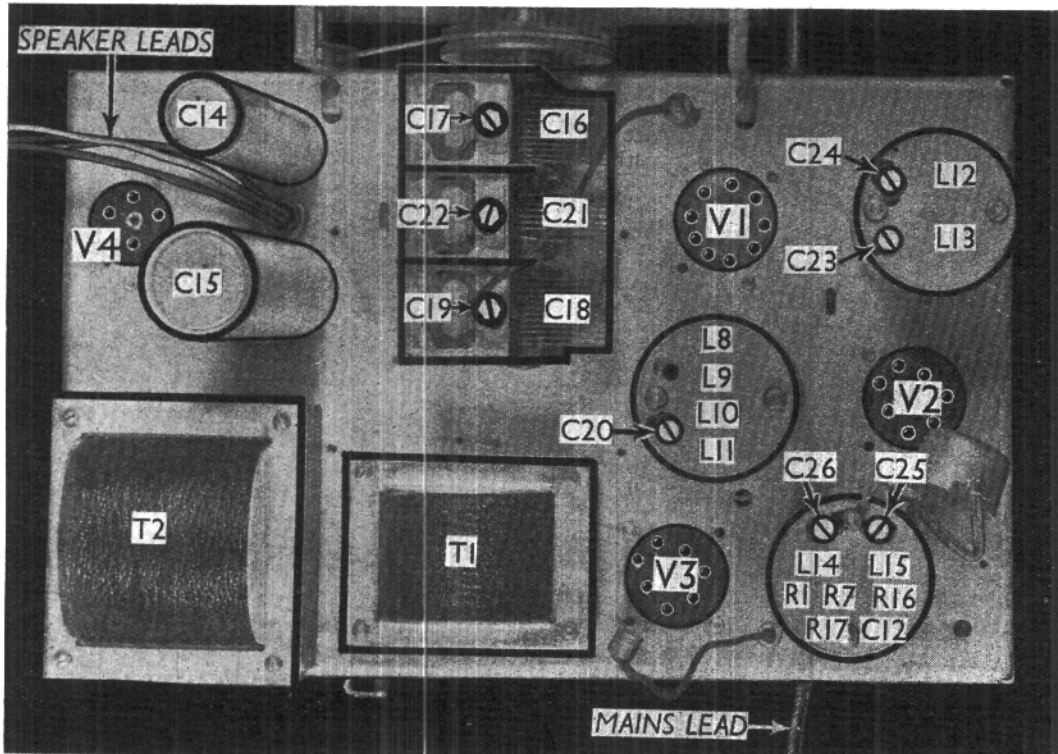

Plan view of the chassis with all trimming condensers clearly shown. The second I.F. transformer unit contains, apart from its trimmers, five other components (see General Notes). **C14** and **C15** are H.T. smoothing condensers of the aqueous electrolytic type.