

ULTRA MODEL 44 MAINS SUPERHET

Circuit.—The combined detector-oscillator valve A.C./T.P., V1 (nine pin) is a triode-H.F. pentode valve. The pentode section follows a band-pass aerial tuner, and oscillation is obtained by coupling coil in the common cathode circuit.

The pentode anode is coupled to the I.F. valve by a band-pass I.F. transformer (frequency 456 kc.). Bias is by A.V.C.

The I.F. valve A.C./VP1 (V2) is biased partly by fixed cathode resistance and partly from a separate tapping on the A.V.C. potentiometer. Coupling to the next valve is by another band-pass I.F. transformer. The neon tube indicator is connected in the anode circuit of this valve.

The combined second detector and output valve A.C./2 Pen. D.D. (V3) (seven pin) uses one of the diode anodes for signal rectification and L.F. purposes and the other for A.V.C.

The L.F. voltages are taken from the low I.F. potential end of I.F.T.2 secondary, through an H.F. choke to the load resistance R10, which forms the volume-control potentiometer.

The grid is biased to a tapping point on the cathode resistance so as to allow a larger voltage drop for the delay bias on the A.V.C. diode. Coupling to the pentode grid is by condenser C14 and leak R19.

The pentode section has both grid and anode stabilising resistances, and is tone-compensated by a resistance and condenser in series between the anode circuit and chassis.

Mains equipment consists of transformer with H.F. by-pass condensers, full-wave UU3 rectifier, and has the L.S. field in the positive H.T. lead for smoothing with electrolytic condensers.

Special Notes.—The tuning indicator is a neon tube with a cathode and two anodes. One anode is connected to H.T.+, through R22, and acts as a tickler or pilot. The other anode is connected to the anode circuit of the I.F. valve.

As the A.V.C. bias causes the anode current of the I.F. valve to fall the voltage rises and the associated anode "raises" the flash in the tube.

(Continued on opposite page.)

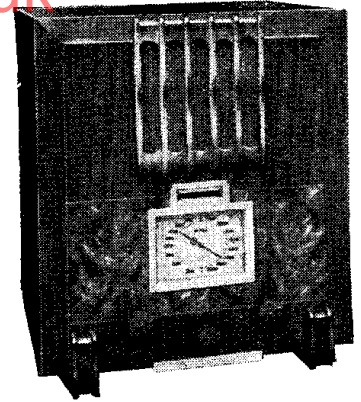

Made by Ultra Electric, Ltd., the model "44" is a three-valve plus rectifier A.C. superhet featuring clock-face tuning and a neon tuning indicator.

VALVE READINGS

[No signal.]

Valve.	Type.	Electrode.	Volts.	Ma.
1	AC/TP ...	anode ...	224	*
		aux. grid ...	160	
		osc. anode ...	100	
2	AC/VP1 ...	anode ...	146	7
		aux. grid ...	150	
3	AC21, Pen.DD	anode ...	219	22
		aux. grid ...	228	5

* Owing to the small space it is not possible to use a split anode adaptor for the current readings.

CONDENSERS

C.	Purpose.	Mfd.
1	Decoupling V1 grid05
2	Decoupling V1 aux. grid1
3	Decoupling V1 pentode anode1
4	Across osc. grid leak0002
5	Across pick-up001
6	Decoupling osc. anode1
7	V1 cathode5
8	V2 cathode1
9	Decoupling H.T. to V2 anode and neon tube.	2
10	Decoupling H.T. to V2 anode	.002
11	L.F. coupling on "gram"1
12	Decoupling V2 aux. grid5
13	Tone compensating on V.C.004
14	L.F. coupling to V3 grid01
15	H.F. by-pass from diode0002
16	Feed to AVC diode0002
17	Decoupling AVC to V205
18	Tone compensating V3 anode	.001
19	Tone compensating V3 anode	.01
20	V3 cathode ...	50 el.
21	H.T. smoothing ...	16 el.
22	H.T. smoothing ...	8
23	H.F. by-pass from mains01
24	H.F. by-pass from mains01

RESISTANCES

R.	Purpose.	Ohms.
1	Voltage drop to neon tube ...	50,000
2	Harmonic suppressor V1 osc. grid	1,000
3	Decoupling V1 aux. grid ...	25,000
4	Osc. grid leak ...	50,000
5	Decoupling V2 aux. grid ...	30,000
6	Decoupling osc. anode ...	80,000
7	V1 cathode bias ...	480
8	V2 cathode bias ...	165
9	Across pick-up ...	20,000
10	Var. volume control5 meg.
11	Decoupling V2 anode ...	3,000
12	Decoupling V2 anode ...	8,000
13	Decoupling AVC to V1 ...	1 meg.
14	Decoupling AVC to V2 ...	1 meg.
15	Part of AVC diode load25 meg.
16	V3 cathode bias75 meg.
17	V3 cathode bias ...	138
18	V3 cathode bias ...	138
19	V3 grid leak ...	1 meg.
20	V3 anode stabiliser ...	50
21	Tone compensating V3 anode ...	15,000
22	Voltage drop to neon tube ...	2 meg.
23	V3 grid stabiliser ...	1,000
—	L.S. field ...	3,000
—	Output transformer primary ...	400

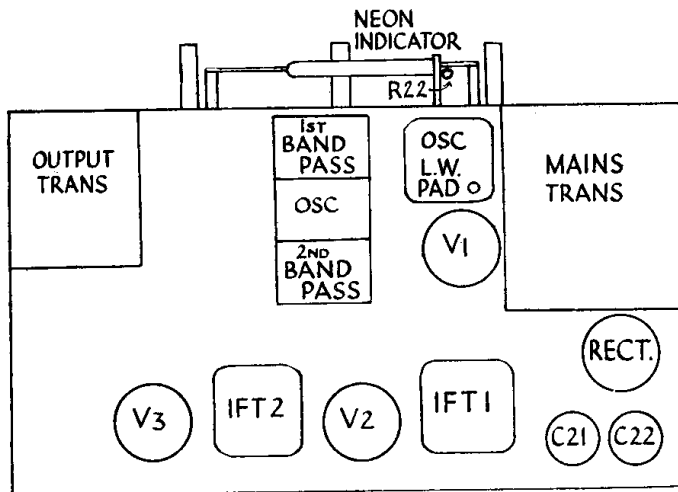

How the neon tuning indicator and its associated resistance are placed is shown by the above chassis layout.

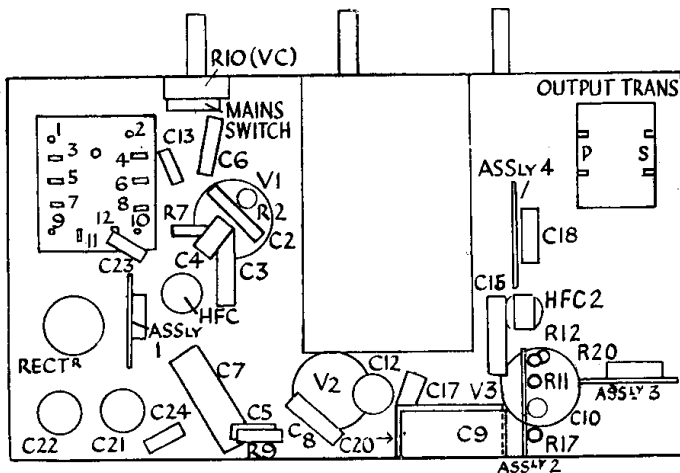

Details of the assemblies indicated in this "below-deck" diagram of the Ultra "44" are given under "General Notes."

ULTRA "44" MAINS SUPERHET (Cont.)

Quick Tests.—Loosen speaker hood and take voltages between the outer terminals on the strip.

Left, red, H.T. smoothed 228 volts; right (black with white tracer), H.T. unsmoothed 400 volts. (These were taken on 230 v. A.C. mains in 230-250 tapping.)

Note that the only valve which has the anode terminal at the top of the bulb is the A.C./V.P1.

Removing Chassis.—Remove knobs (grub screw). Remove four screws underneath and undo the two nuts from the bolts at the side of the speaker (not those on the speaker itself). A box spanner is necessary.

General Notes.—The resistance and condenser assemblies are mounted as follows (See lay-out diagram.) Counting from the base in each case :—

- Assembly 1 : R1, R3, R6, R5.
- Assembly 2 : Shown on diagram.
- Assembly 3 : R23, R19, C14, R8.
- Assembly 4 : R18, C19, R21, C18.

In the circuit diagram in the August issue of the Ultra booklet, R1 was shown as being connected to the junction of R11 and R12 instead of to the low H.T. potential end of R11.

The connection from R1 on Assembly 1 is a yellow lead with a red tracer, which is linked with the cable going to the other side of the set to Assembly 2.

The leads in this set are not coded, but are made of different colours to facilitate tracing the circuit.

Mains transformer connections (see lettering on diagram) :—

- (1) and (2), set heaters.
- (3) 230-250 mains tapping.
- (5) 200-220 mains tapping.
- (7) Mains 0 to switch.
- (9) and (10) Rectifier heaters.
- (11) and (12) Pilot lamps.
- (8) and (4) Rectifier anodes.
- (6) Centre tappings (to chassis).

Replacing Chassis.—Lay chassis inside cabinet, replace nuts on two bolts next the speaker. Replace the knobs and holding screws.

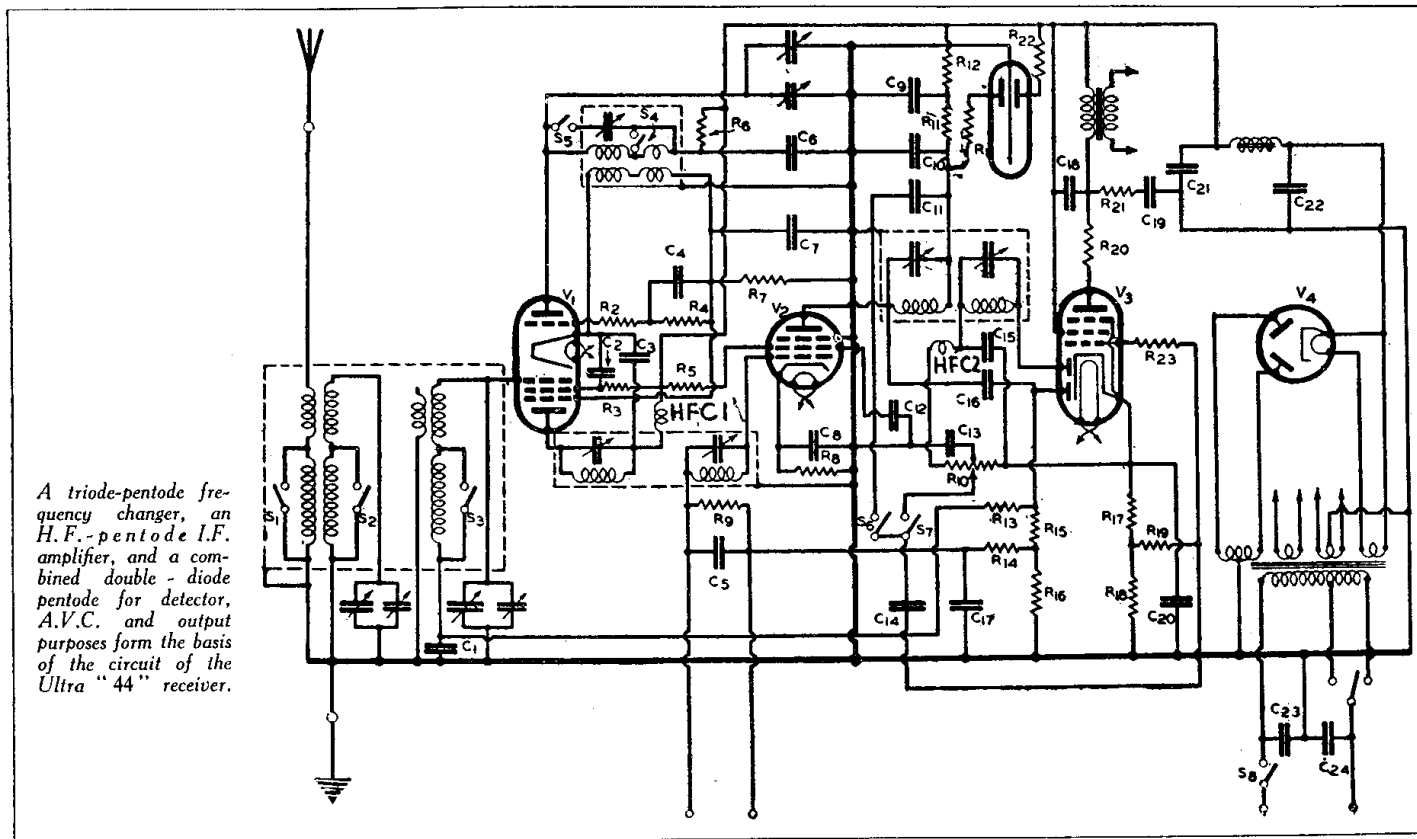

A triode-pentode frequency changer, an H.F.-pentode I.F. amplifier, and a combined double-diode pentode for detector, A.V.C. and output purposes form the basis of the circuit of the Ultra "44" receiver.

ALBA MODEL 21 BATTERY SET

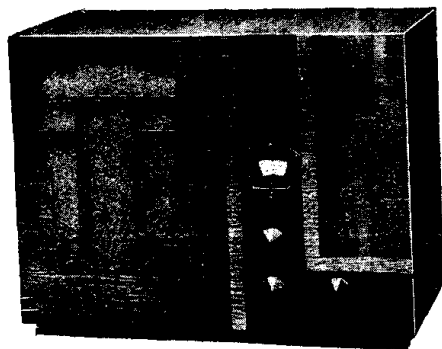

An inexpensive "straight" three employing batteries, the Alba "21" is a product of A. J. Balcombe, Ltd.

Circuit.—The H.F. valve SP2 met. (V1) is preceded by a tuned secondary aerial transformer. Alternative aerial tappings are

provided by means of resistances in series with the aerial lead, and a resistance is connected between the M.W. and L.W. windings on the primary. The grid return lead is taken to chassis.

Coupling to the next valve is by tuned secondary H.F. transformer with a reaction coil. The detector valve PM1HL met. (V2) operates as a leaky grid detector with zero bias provided by having two grid leaks, one connected to L.T.- and the other to L.T.+.

The coupling to the next valve is by "straight" transformer with anode decoupling.

The output pentode PM22A (V3) is tone-compensated by a condenser between the anode and chassis.

Special Notes.—Battery connections: Drydex S49, H.T.+, 108 volts; G.B.-, -3 volts.

The colours are: H.T.+, brown; G.B.-, blue; H.T.-, fawn.

Quick Tests.—These consist of routine battery and valve tests.

Removing Chassis.—Remove knobs (grub screw), undo four holding screws from underneath and lift chassis out. The L.S. leads are sufficiently long to allow the chassis to stand on its side.

General Notes.—The construction and wiring of this set are so simple that it is a fitting subject for the beginner.

(Continued on next page.)

VALVE READINGS

[No reaction. New battery.]

Valve.	Type.	Electrode.	Volts.	Ma.
1	SP2 met (7)	anode ...	107	*1.8
		aux. grid ...	106	
2	PM1HL ...	anode ...	48	1
		aux. grid ...	116	1.8
3	PM22A ...	anode ...	102	6.2
		aux. grid ...	116	1.8

* Inclusion of meter leads makes this valve unstable and a reading of 5 ma. will be recorded. Earth receiver or short-circuit A3 and E.