

**INSTRUCTION
MANUAL
COMMUNICATIONS
RECEIVER
FRG-7**

YAESU MUSEN CO., LTD.

TOKYO JAPAN

TABLE OF CONTENTS

	(Page)
GENERAL DESCRIPTION	1
SPECIFICATION	2
INSTALLATION	3
CONTROLS AND SWITCHES	4
OPERATION	7
BLOCK DIAGRAM	8
CIRCUIT DESCRIPTION	9
ALIGNMENT AND MAINTENANCE	11
VOLTAGE CHART	13
PARTS LIST	14

**“WARNING : TO PREVENT FIRE OR SHOCK HAZARD, DO
NOT EXPOSE THIS APPLIANCE TO RAIN OR MOISTURE.”**

COMMUNICATIONS RECEIVER FRG-7



GENERAL DESCRIPTION

The model FRG-7 is an all solid state synthesized communication receiver designed to cover the entire high frequency spectrum, 500 kHz to 29.9 MHz.

FRG-7 is a triple conversion super heterodyne receiver utilizing synthesized heterodyne oscillator known as the "Wadley Loop System" which offers unparalleled stable performance.

The calibrated dial mechanism provides 10 kHz frequency readout throughout the receiver coverage.

Good selectivity is provided for SSB, AM and CW with the utilization of a ceramic filter in the 455 kHz IF circuits.

The FRG-7 includes three step front end attenuator, amplified AGC and low-normal-high tone select switch for extreme flexibility that even the most demanding amateur, CBer, or broadcast listener desires. In addition, the large cabinet and hi-fi speaker will provide you with high quality audio output.

The FRG-7 includes a self-contained three way power supply for 117 volts AC 50/60 Hz, an internal battery or external 12 volt DC. If the AC power source fails, the unit switches automatically to an internal battery which uses eight "D" dry cells.

To save battery consumption, the dial lamps can be switched off.

SPECIFICATIONS

Frequency Range:
0.5 MHz ~ 29.9 MHz

Speaker Impedance:
4 ohms

Type of Emission:
AM, SSB (USB or LSB), CW

Audio Output:
2 watts

Sensitivity:
SSB/CW: Better than $0.7 \mu\text{V}$ at S/N 10 dB
AM : Better than $2 \mu\text{V}$ at S/N 10 dB

Power Requirement:
117 volts AC 50/60 Hz, 12 volts DC external
or internal dry cell UM-1 x 8

Selectivity:
 ± 3 kHz at -6 dB, ± 7 kHz at -50 dB

Power Consumption:
AC 14VA

Stability:
Less than ± 500 Hz at any 30 minutes after
warm up

Size:
340 (W), 153 (H), 285 (D) mm

Antenna Impedance:
High impedance for 0.5 MHz ~ 1.6 MHz
50 ohm unbalanced for 1.6 MHz ~ 29.9 MHz

Weight:
Approx. 7 kg without batteries

SEMICONDUCTORS COMPLEMENTS

IC:			
AN-214	1	SN76514	1
FET:			
3SK-40	3	2SK19	6
Transistor:			
2SC372	8	2SC784	4
2SD313	1		
Diode:			
1N60AM	9	1S1555	2
V06B	3		
Zener Diode:			
WZ-110	1	BZ091	1

INSTALLATION

Carefully remove the FRG-7 receiver from the carton and examine it for any physical damage.

Should any be apparent immediately notify the carrier stating the damage in detail. Save the carton and packing materials for future use.

Location:

In general, the location of the FRG-7 is not critical, however, it is recommended that excessively warm location be avoided.

POWER REQUIREMENT

The power supply is designed to operate from 117 volt AC 50/60 Hz or 12 volt DC.

CAUTION

PERMANENT DAMAGE WILL RESULT IF IMPROPER AC SUPPLY VOLTAGE IS APPLIED TO THE RECEIVER.

The FRG-7 will operate satisfactorily from any 12 volt, negative ground battery source by connecting the DC power cord (cord is supplied) to the rear panel receptacle. When making connections to the battery, be certain that the inner conductor is connected to the positive (+) and the outer conductor is connected to the negative (-) terminals of the battery. Reversed connection could permanently damage the receiver circuit.

The FRG-7 will also operate from eight dry cells in the built-in dry cell pack. (Cells are not supplied.) If the AC supply fails, the dry cell supply is automatically connected to the circuit.

Table 1 shows the power supply combination of FRG-7.

Power Source	1	2	3	4	5	6	7
AC Supply	○	—	—	○	○	○	—
External DC	—	○	—	×	—	×	○
Internal DC	—	—	○	—	×	×	×

- Power source in use
- ×
- Power source not connected

Table 1

ANTENNA AND GROUND

The antenna is the most important part of the communication receiver installation. The FRG-7 is designed for use with a simple wire antenna for 0.5 ~ 1.6 MHz and with a resonant antenna at the operating frequency having an impedance of 50 to 75 ohms for higher frequency than 1.6 MHz. This requirement is easily met by using a center fed dipole antenna resonant to the receiving frequency and fed with coaxial cable.

The FRG-7 should be connected to a good ground. The ground lead should be connected to the terminal marked E located on the rear panel of the receiver.

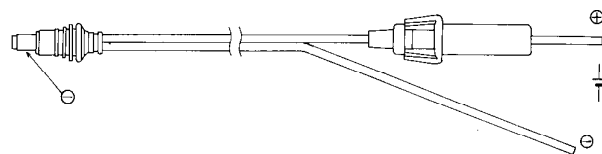
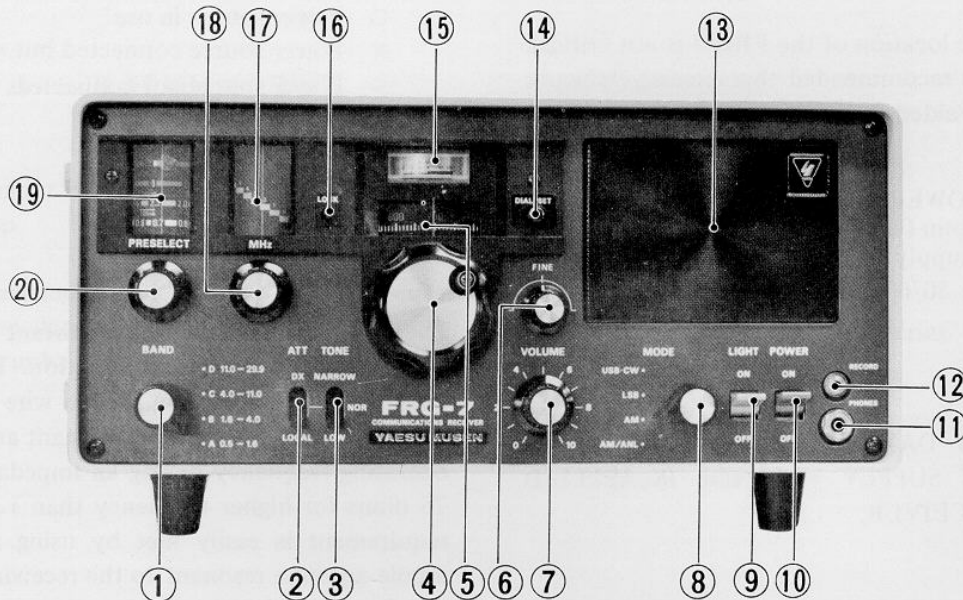

Fig.1 DC Power Cord

CONTROLS AND SWITCHES

The FRG-7 has been designed for ease of operation. All controls have been properly adjusted at the factory. Several panel controls and switches are unusual in operation, and an improper setting may result in poor reception. The function of various controls and switches is described in the following paragraph.

Be certain that you thoroughly understand the individual function of each before operating the receiver.



FRONT PANEL

(1) BAND

The BAND switch is a four position switch. The switch selects the desired frequency range.

(2) ATT (NOR, DX, LOCAL)

The ATT (attenuator) switch attenuates the incoming signal to prevent over-loading of the front end when an extremely strong signal is present. At the switch NOR (normal) position, the attenuator is removed from the input circuit.

(3) TONE (NOR, NARROW, LOW)

The TONE switch changes audio response of the receiver. The audio amplifier passes at the NOR position, 250 Hz through 3000 Hz, at NARROW 400 Hz through 2500 Hz and at LOW 250 Hz through 1500 Hz.

(4) (5) TUNING DIAL

The main TUNING knob determines the frequency

in combination with the BAND switch and MHz setting.

(6) FINE TUNING

The FINE TUNING control is used for precise tuning of the received signal. The main tuning dial is calibrated to the frequency with the fine control at centre.

(7) VOLUME

The VOLUME controls the audio output level from the speaker.

(8) MODE

The MODE switch determines the appropriate detector in use. In the USB-CW position, the USB (Upper Side Band) and code signal is heard. In the LSB position, the LSB (Lower Side Band) signal is heard. In the AM position, the amplitude modulated signal is heard and the Noise Limiter is put into the circuit in the AM/ANL position.

(9) LIGHT

This switch is used to turn off the lamp so as to save the current drain when the FRG-7 is operated from internal dry cells.

(10) POWER

This switch turns off the supply voltage for both AC and DC operation.

(11) PHONES

Phone jack is provided for private listening and the speaker is disconnected when the plug is inserted in this jack.

(12) RECORD

This jack is for recording purpose and the output level is set to approximately 50 mV regardless of setting of the VOLUME control.

(13) SPEAKER

Internal Speaker.

(14) DIAL SET

Main tuning dial calibrator.

(15) S-METER

The S-meter indicates the relative signal strength of the received signal. It is calibrated in S-unit from S-1 to S-9 and in dB over S-9.

(16) LOCK

The LOCK lamp lights up when the synthesized heterodyne oscillator is unlocked.

(17) (18) MHz

This MHz control synthesizes heterodyne oscillator to the harmonics of 1 MHz crystal oscillator. The scale is calibrated in MHz with the frequency showing the correct setting of the heterodyne signal.

(19) (20) PRESELECT

The PRESELECTOR control tunes the receiver front end. The scale is calibrated with the frequency showing the correct setting for various bands.



Fig. 2 Headphone Connection

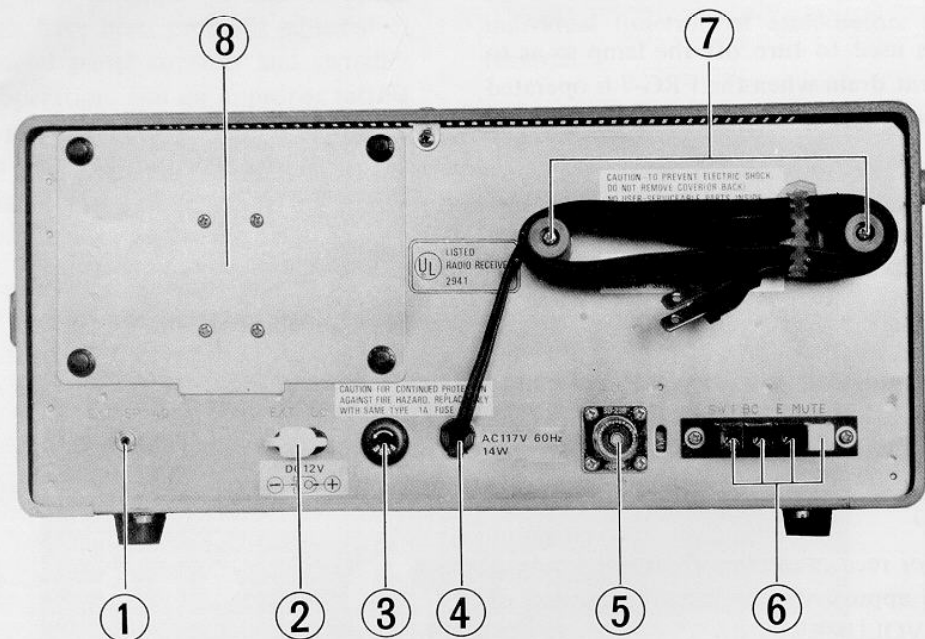

REAR PANEL CONNECTION

(1) EXT SP

This jack is for connection of a 4 ohm external speaker when desired. With the plug in the S jack, the internal speaker is disconnected.

(2) EXT DC

Receptacle for external 12 volts DC supply.

(3) FUSE

Fuse for AC operation. Use 1 amp rating fuse.

(4) AC cord

Cord for AC operation.

(5) SW2

Coaxial connector for short wave listening.

(6) SW, BC, E, MUTE

SW is long wire antenna terminal for the short wave listening.

BC is long wire antenna terminal for the broadcast band listening.

E is ground connection.

MUTE is used to disable the receiver while transmitting. Connect this terminal to ground for receiver muting.

(7) (8)

AC cord holder and the internal battery pack. Use eight "D" cells.

OPERATION

FREQUENCY SELECTION

The receiving frequency is selected by the combination of the MHz dial and main tuning dial settings. The MHz dial selects the band at every 1 MHz and the main tuning dial selects the frequency at 10 kHz increment from 0 to 990 kHz in the band. The combination of these controls is shown in Table 2.

AMATEUR BAND RECEPTION

SSB Voice Signal:

Most amateurs use LSB on frequencies lower than 10 MHz and USB on frequencies higher than 10 MHz.

Set the controls and switches as follows;

POWER OFF
 BAND Desired frequency segment
 ATT NOR
 TONE NOR
 VOLUME Desired listening level

	Frequency	PRESELECT	MHz	Main Dial	BAND	MODE
Amateur	kHz 1,910	2.0 1.8	2 0	9 1 0	B1.6~4.0	USB · CW
	3,525	3.6 3.3 90mb	4 3 2	5 2 5	B1.6~4.0	LSB
	7,050	8 7 41mb 49mb	8 7 6	0 5 0	C4.0~11.0	LSB
	14,175	15 13 19mb	15 14 13	1 7 5	D11.0~29.9	USB · CW
	21,225	23 20 13mb	23 22 21 20	2 2 5	D11.0~29.9	USB · CW
	28,850	30 26 11mb	29 28 27	8 5 0	D11.0~29.9	USB · CW
Medium Wave	590	0.6	1 0	5 9 0	A0.5~1.6	AM or AM/ANL
	980	1.0 0.8	1 0	9 8 0	A0.5~1.6	AM or AM/ANL
	1,170	1.2 1.0	2 0	1 7 0	A0.5~1.6	AM or AM/ANL
WWV/JJY	2,500	2.6 2.3 120mb	3 2 1	5 0 0	B1.6~4.0	AM or AM/ANL
	5,000	5 4 60mb	6 5 4	0	C4.0~11.0	AM or AM/ANL
	10,000	11 10 9 31mb	11 10	0	C4.0~11.0	AM or AM/ANL
	15,000	17 15 19mb	16 15 14	0	D11.0~29.9	AM or AM/ANL
Short Wave	3,925	4.0 3.6 75mb	4 3 2	9 2 5	B1.6~4.0	AM or AM/ANL
	5,980	6 49mb	6 5 4	9 8 0	C4.0~11.0	AM or AM/ANL
	9,715	10 9 31mb	9 8	7 1 5	C4.0~11.0	AM or AM/ANL
	11,705	12 11 25mb	12 11 10	7 0 5	D11.0~29.9	AM or AM/ANL
	15,120	17 15 19mb	16 15 14	1 2 0	D11.0~29.9	AM or AM/ANL
	17,880	20 17 16mb	18 17 16	8 8 0	D11.0~29.9	AM or AM/ANL
	21,550	23 20 13mb	22 21 20	5 5 0	D11.0~29.9	AM or AM/ANL

Table. 2

MODE	LSB for 160, 80 and 40 meter bands	
	USB for 20, 15 and 10 meter bands	
DIAL SET	Center	
PRESELECT	Desired frequency. Refer to Table 2.	
MHZ	"	"
MAIN DIAL	"	"

CW (Morse Code Signal):

The code signal can be heard with the MODE switch at USB/CW position and by tuning the main tuning dial for a desired listening tone.

Turn the POWER switch on. Precisely adjust the MHZ dial until the LOCK lamp turns off. Tune the main tuning dial for the desired signal until the signal is clearly heard. Use the FINE TUNING control for precise tuning. When the received signal is garbled, try the opposite sideband. When an extremely strong signal is distorted, peak the PRESELECTOR for a maximum S-meter reading.

BROADCAST RECEPTION

The broadcast signal is transmitted on AM mode. If any pulse type noise is experienced, set the MODE switch to AM/ANL position to reduce the noise interference.

Set the ATT switch to LOCAL position to avoid front end over loading. Set the VOLUME for desired listening level.

The amateur SSB signals cut high and low audio response, so that it may be helpful to reduce the interference by setting the TONE switch at NARROW or LOW position.

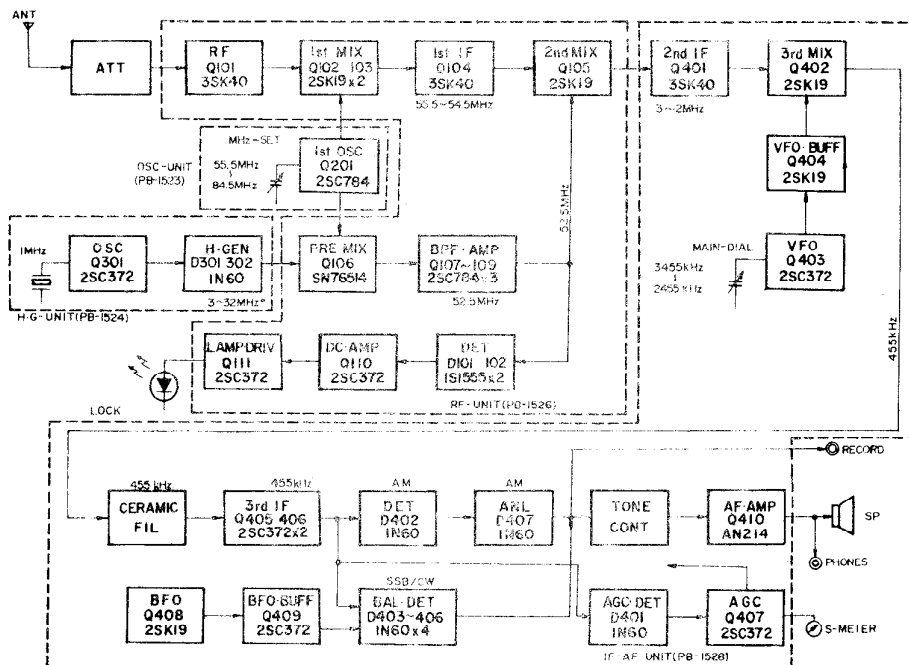

Fig 3 BLOCK DIAGRAM

CIRCUIT DESCRIPTION

The block diagram will provide you with a better understanding of this receiver. In general, the FRG-7 is a tripple conversion super heterodyne receiver utilizing synthesized local oscillator for both the first and second mixers for drift free VFO operation.

The signal from the antenna is fed through the attenuator to the gate of the FET RF amplifier Q_{101} , **3SK40**. The amplified signal is fed through a low pass filter (cut off frequency 35 MHz) to the first balanced mixer consisting of Q_{102} and Q_{103} , **2SK19**, where the incoming signal is mixed with a signal from the heterodyne oscillator. The first heterodyne oscillator Q_{201} , **2SC784**, oscillates the signal which varies between 55.5 and 84.5 MHz.

The product of the first mixer becomes the first IF signal of 54.5 through 55.5 MHz. The first IF signal is amplified by the first IF passband amplifier Q_{104} and fed to the gate of the second mixer Q_{105} , **2SK19GR**, where the first IF signal is mixed with 52.5 MHz signal. The second mixer converts the first IF signal into the second IF signal of 2.0 through 3.0 MHz.

Synthesizer oscillator Q_{301} , **2SC372**, oscillates crystal controlled 1 MHz signal. The 1 MHz signal is then fed to the harmonic generator D_{301} and D_{302} , **1N60**, which produces 3 to 32 MHz harmonics from the 1 MHz crystal controlled signal. The harmonic signal is fed to the dual balanced pre-mixer Q_{106} , **SN76514**, where the harmonics are mixed with the signal from the first heterodyne oscillator Q_{201} . The output signal from the pre-mixer passes through the selective amplifier Q_{107} , Q_{108} and Q_{109} , **2SC784**, which eliminates other signals except the 52.5 MHz second heterodyne signal.

A part of the output from the selective amplifier is rectified by the detectors D_1 and D_2 , **1S1555**, and the DC output voltage is amplified by the DC amplifier Q_{110} , **2SC372**, and then fed to the LOCK lamp driver Q_{111} , **2SC372**, which turns the LOCK lamp on when the synthesizer is unlocked.

The output signal from the first IF amplifier Q_{104} is fed to the second mixer Q_{105} , **2SK19**, where the

incoming signal is mixed with the 52.5 MHz signal from the selective amplifier. The output of the second mixer becomes second IF signal of 2.0 through 3.0 MHz. The 2.0 to 3.0 MHz IF signal is then amplified by the second IF amplifier Q_{401} , **3SK40**, and then fed to the third mixer Q_{402} , **2SK19**. The third mixer converts the second IF signal into 455 kHz third IF signal. The VFO (main tuning) signal, which varies between 2,455 kHz and 3,455 kHz, is generated by the variable frequency oscillator Q_{403} , **2SC372**, and supplied to the third mixer through the buffer amplifier Q_{404} , **2SK19**. The 455 kHz IF signal from the third mixer is fed to the ceramic filter which is tuned to 455 kHz and has ± 3 kHz passband response to eliminate interference.

The signal is then amplified by the third amplifier Q_{405} and Q_{406} , **2SC372**, and fed to the appropriate detector. The AM signal is detected by balanced diode detector D_{402} , **1N60AM**.

The balanced demodulator D_{403} through D_{406} , **1N60AM**, is used for the detection of SSB and CW signals. The carrier signal for SSB and the beat frequency signal for CW which is generated by the BFO oscillator Q_{408} , **2SK19**, are fed to the balanced demodulator through buffer amplifier, Q_{409} , **2SC372**. The MODE switch shifts the BFO frequency 3 kHz lower than LSB position for USB and CW signal reception.

A part of the output from the last IF amplifier Q_{406} is fed to the AGC (Automatic Gain Control) rectifier D_{401} , **1N60**. The rectified AGC voltage is then amplified by the AGC amplifier Q_{407} , **2SC372**, and fed to the Q_{101} , Q_{401} and Q_{405} to control the gain of these stages automatically when the incoming signal strength is varied. Thus the receiver audio output is not effected by the variation of the input signal strength which may be caused by phasing. The S-meter is placed in the emitter circuit of Q_{407} , in which the emitter current changes in accordance with the incoming signal strength.

The detected audio output is fed through the MODE switch and the VOLUME control potentiometer VR_1 to the audio amplifier integrated circuit

Q₄₁₀, AN-214, which utilizes OTL (Output Transformer Less) circuit delivering 3 watts to the speaker.

The power supply is designed to operate from 117 volt AC 50/60 Hz or 12 volt DC (negative ground). For AC operation, +13.5 volts are supplied from full wave rectifier D₄₀₈ and D₄₀₉, V06B.

The 13.5 volts are used for audio amplifier stage.

The DC voltage in both AC or DC operation is supplied to the voltage regulator Q₁₁₁, 2SD313, to obtain an extremely stable 10 volt DC supply which is used by the various circuits. The 10 volt DC is further regulated by zener diode D₄₁₃, BZ-091, at 9 volts, and then supplied to the oscillators and harmonic generator circuits. When the AC supply fails, the DC voltage may be automatically supplied to the circuit through the diode D₄₁₀, V06B, which prevents the rectified DC voltage from flowing into the battery.

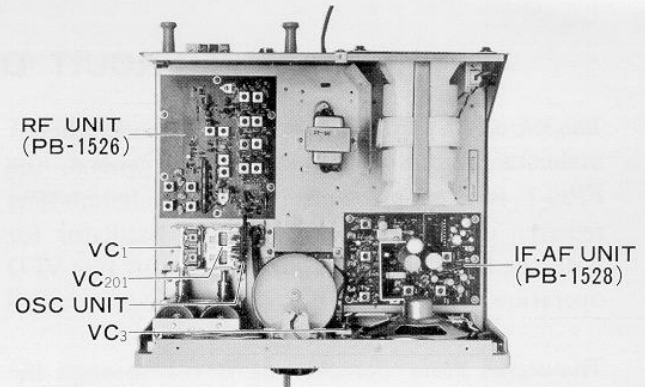

TOP VIEW

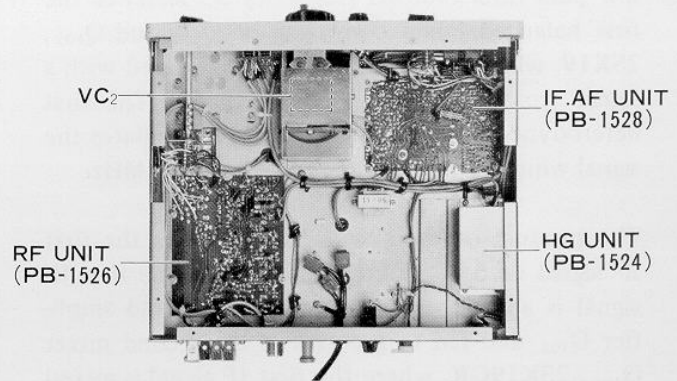

BOTTOM VIEW

FREQUENCY	1ST OSC	1ST IF (f _{o1} -f _i) f _{i1}	REF FREQ (1MHz × n) f _h	2ND OSC (f _{o1} -f _h) f _{o2}	2ND IF (f _{i1} -f _{o2}) f _{i2}	3RD OSC f _{o3}	3RD IF (f _{o3} -f _{i2}) f _{i3}
500kHz	55.5MHz	55.0MHz	3MHz	52.5MHz	2,500kHz	2,955kHz	455kHz
1,500	56.5	55.0	4	"	2,500	2,955	"
2,500	57.5	55.0	5	"	2,500	2,955	"
3,500	58.5	55.0	6	"	2,500	2,955	"
4,500	59.5	55.0	7	"	2,500	2,955	"
5,500	60.5	55.0	8	"	2,500	2,955	"
6,500	61.5	55.0	9	"	2,500	2,955	"
7,500	62.5	55.0	10	"	2,500	2,955	"
8,500	63.5	55.0	11	"	2,500	2,955	"
9,500	64.5	55.0	12	"	2,500	2,955	"
10,000	65.5	55.5	13	"	3,000	3,455	"
11,000	66.5	55.5	14	"	3,000	3,455	"
12,000	67.5	55.5	15	"	3,000	3,455	"
13,000	68.5	55.5	16	"	3,000	3,455	"
14,000	69.5	55.5	17	"	3,000	3,455	"
15,000	70.5	55.5	18	"	3,000	3,455	"
16,000	71.5	55.5	19	"	3,000	3,455	"
17,000	72.5	55.5	20	"	3,000	3,455	"
18,000	73.5	55.5	21	"	3,000	3,455	"
19,000	74.5	55.5	22	"	3,000	3,455	"
20,000	75.5	55.5	23	"	3,000	3,455	"
21,100	76.5	55.4	24	"	2,900	3,355	"
22,200	77.5	55.3	25	"	2,800	3,255	"
23,300	78.5	55.2	26	"	2,700	3,155	"
24,400	79.5	55.1	27	"	2,600	3,055	"
25,500	80.5	55.0	28	"	2,500	2,955	"
26,600	81.5	54.9	29	"	2,400	2,855	"
27,700	82.5	54.8	30	"	2,300	2,755	"
28,800	83.5	54.7	31	"	2,200	2,655	"
29,900	84.5	54.6	32	"	2,100	2,555	"

Table 3 Frequency Relationship

MAINTENANCE & ALIGNMENT

The FRG-7 has been carefully aligned and tested at the factory using the precise test instruments before shipment and, with normal usage, it should not require other than the usual attention given to any electronic equipment. Service or replacement of major component may require substantial realignment, however, under no circumstances, should realignment be attempted unless the operation of the receiver is fully understood and the malfunction has been fully analyzed and traced to misalignment. Service work should only be performed by experienced personnel using proper test equipment.

TEST EQUIPMENT REQUIRED

- (1) RF Signal Generator; Hewlett-Packard Model 606A or equivalent with one volt output at an impedance of 50 ohms and a frequency coverage to 30 MHz.
- (2) Vacuum Tube Volt-Ohm Meter (VTVM): Hewlett-Packard Model 401B or equivalent VTVM with RF probe workable to 60 MHz.
- (3) Sweep Generator and Oscilloscope workable to 60 MHz.
- (4) Frequency Counter; Yaesu YC-500 or equivalent workable to 60 MHz.

RF UNIT PB-1526

(1) 55 MHz Passband Circuit, $T_{105} \sim T_{108}$

Set the BAND switch to D and the MHz dial to 20 MHz position. Disconnect the antenna. Connect the sweep generator output between TP_{103} and TP_{102} (ground), and the oscilloscope input between TP_{104} and TP_{105} (ground). Set the center frequency of the sweep generator to 55 MHz and align T_{105} through T_{108} until the scope indicates the curve shown in Fig. 4. Disconnect the sweep generator and the scope.

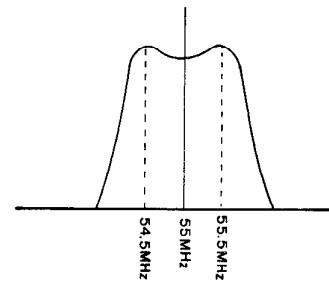

Fig. 4

(2) Balanced Mixer, VR_{101} , TC_{105}

Set the BAND switch to A and the MHz dial to 0. Disconnect the antenna, and connect its output to antenna terminal. Tune the receiver to the internal spurious signal at 910 kHz. Adjust VR_{101} and TC_{105} for minimum S-meter indication.

(3) Antenna Coil and Trimmer, $T_{101} \sim T_{104}$, $TC_{101} \sim TC_{104}$

Connect the signal generator output to the antenna terminal SW_2 and connect SW_1 and BC terminals with a copper wire.

Set the signal generator to 0.5 MHz, the BAND to A and PRESELECT to 0.5. Tune the receiver to the signal generator signal. Adjust T_{101} for maximum S-meter reading. Repeat this procedure at the frequencies shown in Table 4.

FREQ	BAND	PRESELECT	ALIGNMENT
0.5MHz	A	0.5	T101
1.6MHz	A	1.6	TC101
1.6MHz	B	1.6	T102
4.0MHz	B	4.0	TC102
4.0MHz	C	4.0	T103
11.0MHz	C	11.0	TC103
11.0MHz	D	11.0	T104
30.0MHz	D	30.0	TC104

Table 4

Disconnect the signal generator and the copper wire between SW₁ and BC.

(4) 52.5 MHz Selective Filter, T₁₀₉ ~ T₁₁₆

Disconnect the input from the oscillator unit at TP₁₀₁. Connect the sweep oscillator output between TP₁₀₇ and ground, and the scope between TP₁₀₉ and ground. Set the center frequency of the sweep generator to 52.5 MHz. Adjust T₁₀₉ to T₁₁₆ until the scope screen shows the curve shown in Fig. 5.

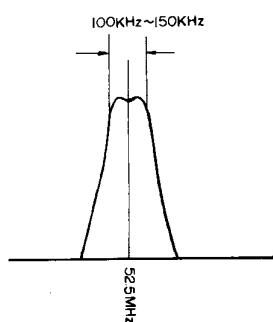

Fig.5

Disconnect the sweep generator and scope and reconnect the wiring at TP₁₀₁. After completion of the above procedures make sure that the RF voltage between TP₁₁₀ and ground is approximately 0.3 to 0.5 volt RMS. If not, repeat procedure.

(5) LOCK Level, VR₁₀₂

Adjust VR₁₀₂ until the LOCK lamp turns off at any MHz setting of the MHz dial.

OSC UNIT PB-1523

(1) MHz Setting, T₂₀₁, TC₂₀₁

Connect the signal generator to antenna connector SW₂ and set its frequency to 3.5 MHz. Tune the receiver to the signal generator signal. Adjust T₂₀₁ carefully until the LOCK lamp turns off at the center of 3 MHz scale on the MHz dial. Set the signal generator frequency to 27.5 MHz and tune the receiver to this signal. Carefully adjust TC₂₀₁ until the LOCK lamp turns off at the center of 27 MHz scale on the MHz dial. Repeat above procedures until the LOCK lamp turns off at the center of every MHz scale, from 0 to 29 MHz. Disconnect the signal generator.

IF AF UNIT PB-1528

(1) Main Tuning Dial, T₄₀₃, TC₄₀₃

The following alignment should be done after warm-up of the receiver.

Set the dial hair line to the center of the dial window and FINE TUNING control to 12 o'clock position. When the main tuning dial is rotated until it stops over 1000 scale, ▲ mark should be within 5 m/m from the hair line.

Set the MODE switch to LSB and MHz dial to 0. Set the main tuning dial to 1000, then beat tone will be heard. Adjust T₄₀₃ for zero beat. Set the main tuning dial to 0 and adjust TC₄₀₃ for zero beat. Repeat above procedures until the tracking is completed.

(2) 2nd IF Tracking, TC₄₀₁, TC₄₀₂, T₄₀₁, T₄₀₂

Connect the signal generator to the antenna terminal SW₂ and set its frequency to 7.1 MHz. Tune the receiver to the signal from the signal generator. Set the output voltage from the signal generator for S-3 reading on S-meter. Adjust TC₄₀₁ and TC₄₀₂ for maximum S-meter reading. Set the signal generator to 7.9 MHz and tune the receiver to 7.9 MHz signal. Adjust T₄₀₁ and T₄₀₂ for maximum S-meter reading. Repeat these procedures until the tracking is completed.

(3) 3rd IF, T₄₀₄, T₄₀₅

Set the signal generator to 7.5 MHz and tune the receiver to this frequency. Adjust T₄₀₄ and T₄₀₅ for maximum S-meter reading. Adjust signal level so as not to saturate.

(4) S-meter Sensitivity, VR₄₀₁

Set the output level of the signal generator to 100 dB. And tune the receiver for maximum S-meter reading. Adjust VR₄₀₁ for S-meter full scale. Disconnect the signal generator.

(5) BFO Frequency, T₄₀₆, TC₄₀₄

Connect a frequency counter to TP₄₀₅. Set the MODE switch to LSB. Adjust T₄₀₆ for 457 kHz on the frequency counter reading. Set the MODE switch to USB/CW and adjust TC₄₀₄ for 453 kHz.

VOLTAGE CHART

	E (S)	C (D)	B (G)		E (S)	C (D)	B (G)
Q101	1.5	4.2	G ₁ 1.5 G ₂ 4.0		Q301	0.2	8.0
Q102	1.6	9.0	0		Q401	2.0	G ₁ 1.6 G ₂ 2.7
Q103	2.2	9.0	0		Q402	1.8	9.2
Q104	0.5	9.0	G ₁ 0 G ₂ 4.5		Q403	1.8	3.5
Q105	2.0	9.2	0		Q404	0.5	7.8
Q107	0.7	9.2	1.3		Q405	4.3	8.5
Q108	1.1	9.2	1.7		Q406	1.4	9.1
Q109	1.4	8.8	2.0		Q407	0.01	8.7
Q110	0	0.02	0.5		Q408	1.4	6.8
Q111	0	9.5	0.02		Q409	2.2	7.0
Q201	1.8	7.7	1.2		Q411	9.5	13.5

	1	2	3	4	5	6	7	8	9	10	11	12	13	14
Q100	0	8.2	8.2	4.2	2.6	0	0	0	2.2	4.1	4.1	4.2	7.3	0
Q210	6.5	0	7.8	11.0	6.5	0	6.5	12	13.5	—	—	—	—	—

BAND.....4.0~11.0 MHz.....7 MODE.....USB/CW Measured with VTVM Values are in VOLTS DC

Table 5

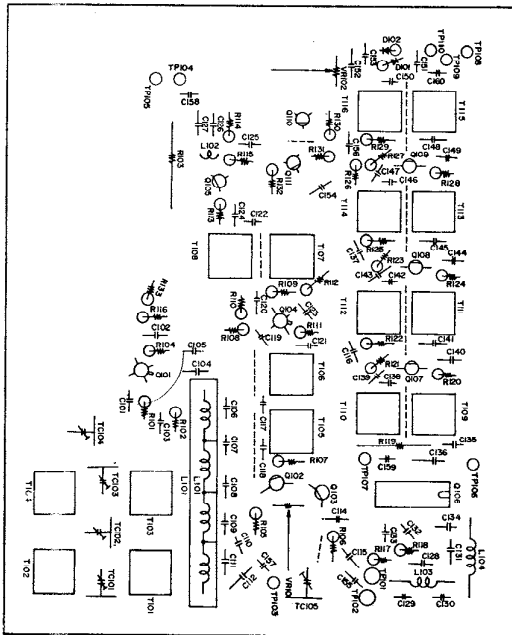

RF UNIT(PB-1526)

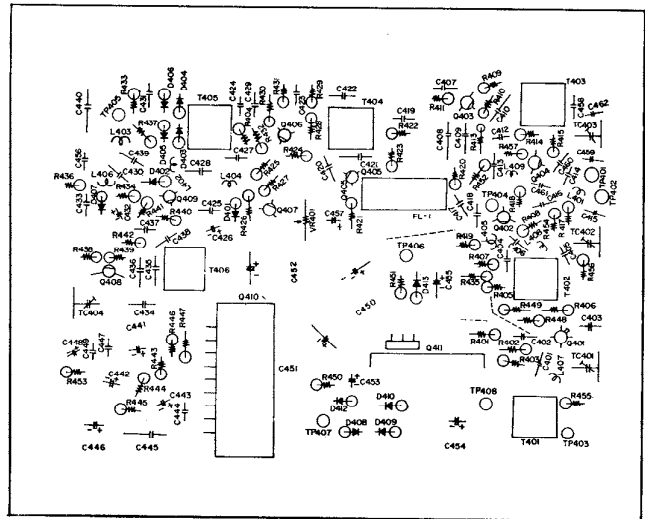

IF-AF UNIT(PB-1528)

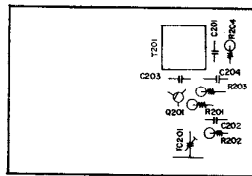

OSC UNIT(PB-1523)

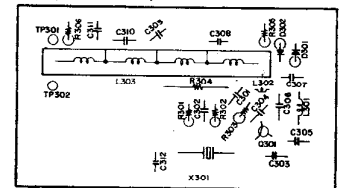

HG UNIT(PB-1524)

PARTS LIST

MAIN CHASSIS				5	#9929		
PB PRINTED CIRCUIT BOARD				6 (P-6)	#4003A		
1390(A~Z)	LED BOARD		7	SG-8050-07			
1525(A~Z)	SWITCH BOARD						
1560(A~Z)	LAMP BOARD						
				F FUSE			
D DIODE				1	1 A		
D							
2,3	Si	V06B					
1	LED	SL-103		FH FUSE HOLDER			
				1	SN-1301		
R RESISTOR							
CARBON FILM							
1, 2		1/4W	10Ω	PL PILOT LAMP			
5, 9		1/4W	68Ω	1, 2, 3, 4, 5, 8	BQ041-32404A		
3, 6, 12		1/4W	100Ω	6, 7	BQ044-32433A		
4		1/4W	1KΩ				
7, 11		1/4W	3.3KΩ				
10		1/4W	10KΩ				
8		1/4W	22KΩ				
CARBON COMPOSITION				RF UNIT			
13		1/2W	56Ω	PB PRINTED CIRCUIT BOARD			
14		1/2W	68Ω	1526(A~Z)			
15, 16, 17		1/2W	2.2MΩ	Q IC, FET & TRANSISTOR			
VR POTENTIOMETER				106	IC SN76514N		
1	EVH-BOAS	20A14	10KA	101, 104	FET 3SK40M		
				102, 103, 105	FET 2SK19GR		
				110, 111	Tr 2SC372Y		
				107~109	Tr 2SC784R (O)		
C CAPACITOR				D DIODE			
CERAMIC DISC				101, 102	Si 1S1555		
4		50WV	22PF(SL)	R RESISTOR			
3		50WV	33PF(SL)	CARBON FILM			
6, 7		50WV	0.047μF	132	1/4W	100Ω	
MYLAR				102, 103, 107, 111, 112	1/4W	220Ω	
2		50WV	0.02μF	115, 125, 129			
1		50WV	0.068μF	119, 122	1/4W	330Ω	
ELECTROLYTIC				118, 128	1/4W	470Ω	
5		16WV	100μF	104, 105	1/4W	560Ω	
VC VARIABLE CAPACITOR				117, 120, 124	1/4W	1KΩ	
1		C123A119	300PF×2	114	1/4W	3.3KΩ	
2		C134ER20	320PF×3	126	1/4W	4.7KΩ	
3		TSN 150S×05		136, 137	1/4W	6.8KΩ	
PT TRANSFORMER				130	1/4W	8.2KΩ	
1		52-50		127	1/4W	15KΩ	
				123	1/4W	22KΩ	
				121	1/4W	27KΩ	
				109, 110	1/4W	33KΩ	
CT CHOKE				116	1/4W	39KΩ	
1		50-11		133	1/4W	47KΩ	
				101, 106, 108, 113, 131, 135, 138	1/4W	100KΩ	
				134	1/4W	330KΩ	
M METER				CARBON COMPOSITION			
1		SH-44		135	1/8W	100KΩ	
				134	1/8W	330KΩ	
SP SPEAKER				VR POTENTIOMETER			
1		SA-128	4Ω 2W	102	EVN-S3A-B13	1KB	
				101	EVN-S3A-B53	5KB	
S SWITCH				C CAPACITOR			
CERAMIC				159	50WV	1PF(CH)	
1	ATT	ESL-3037		117, 138, 142, 146	50WV	2PF(CH)	
4	TONE	ESL-3037		106, 109, 122, 160	50WV	3PF(CH)	
2	BAND	ESR-E264R20		111, 130, 150	50WV	5PF(CH)	
3	MODE	ESR-E264R20		128, 131	50WV	10PF(CH)	
5	POWER	8H2011		119	50WV	15PF(CH)	
6	LAMP	8H2011		129, 157, 158, 161	50WV	22PF(CH)	
				110	50WV	27PF(CH)	
J CONNECTOR				107, 108	50WV	33PF(CH)	
1		JSO-239		168	50WV	39PF(CH)	
2		SQ-2450-03		139, 143,	50WV	47PF(CH)	
3		SG-8050-07		124	50WV	82PF(CH)	
4		SG-7814		114	50WV	100PF(SL)	

410, 425, 443	$\frac{1}{4}$ W	18K Ω	ACCESORIES	
446	$\frac{1}{4}$ W	22K Ω	EXTERNAL SPEAKER PLUG	P2240
409	$\frac{1}{4}$ W	33K Ω	RECORD PLUG	P2240
401, 455, 456	$\frac{1}{4}$ W	47K Ω	PHONES PLUG	SH3010
405, 440	$\frac{1}{4}$ W	68K Ω	DC POWER CORD with 1A FUSE	#240027
402, 408, 414, 434	$\frac{1}{4}$ W	100K Ω	ANTENNA WIRE A	#250003
435	$\frac{1}{4}$ W	150K Ω	ANTENNA WIRE B	#250004
421	$\frac{1}{4}$ W	220K Ω	FUSE	1A
VR POTENTIOMETER				
401	EVL-S0A B32		300 Ω B	
C CAPACITOR				
DIPPED MICA				
462	50WV	20PF		
458	50WV	33PF		
434	50WV	100PF		
410	50WV	120PF		
435, 436	50WV	620PF		
409	50WV	680PF		
408	50WV	1000PF		
CERAMIC				
420, 424	50WV	1PF (CH)		
438	50WV	10PF (CH)		
412	50WV	22PF (CH)		
459	50WV	100PF (UJ)		
427, 428,	50WV	100PF (SL)		
415	50WV	150PF (SL)		
414	50WV	220PF (SL)		
430	50WV	0.001 μ F		
401, 402, 405 ~ 407	50WV	0.01 μ F		
416, 417, 422, 425, 431				
439, 461				
403, 404, 413, 418, 419	50WV	0.047 μ F		
421, 423, 429, 437, 461				
MYLAR				
444	50WV	0.003 μ F		
456	50WV	0.0047 μ F		
433	50WV	0.01 μ F		
447, 449	50WV	0.03 μ F		
440, 445	50WV	0.2 μ F		
ELECTROLYTIC				
448	16WV	1 μ F		
432, 457	16WV	2.2 μ F		
453, 455	16WV	10 μ F		
442, 443	16WV	33 μ F		
426	16WV	47 μ F		
441, 446, 454, 463	16WV	100 μ F		
450 ~ 452	16WV	1000 μ F		
TC TRIMMER CAPACITOR				
403, 404	ECV-1ZW	20 \times 32	20PF	
401, 402,	ECV-1ZW	50 \times 32	50PF	
L INDUCTOR				
407, 408	RFC	4.7 μ H		
401	RFC	27 μ H		
409	RFC	100 μ H		
405	RFC	1mH		
402 ~ 404, 406	RFC	3.9mH		
T TRANSFORMER				
401	# 220060			
402	# 220061			
403	# 220062			
404, 405	R12-4097			
406	R12-4099			

SI ATT
LOCAL-OFF-DX

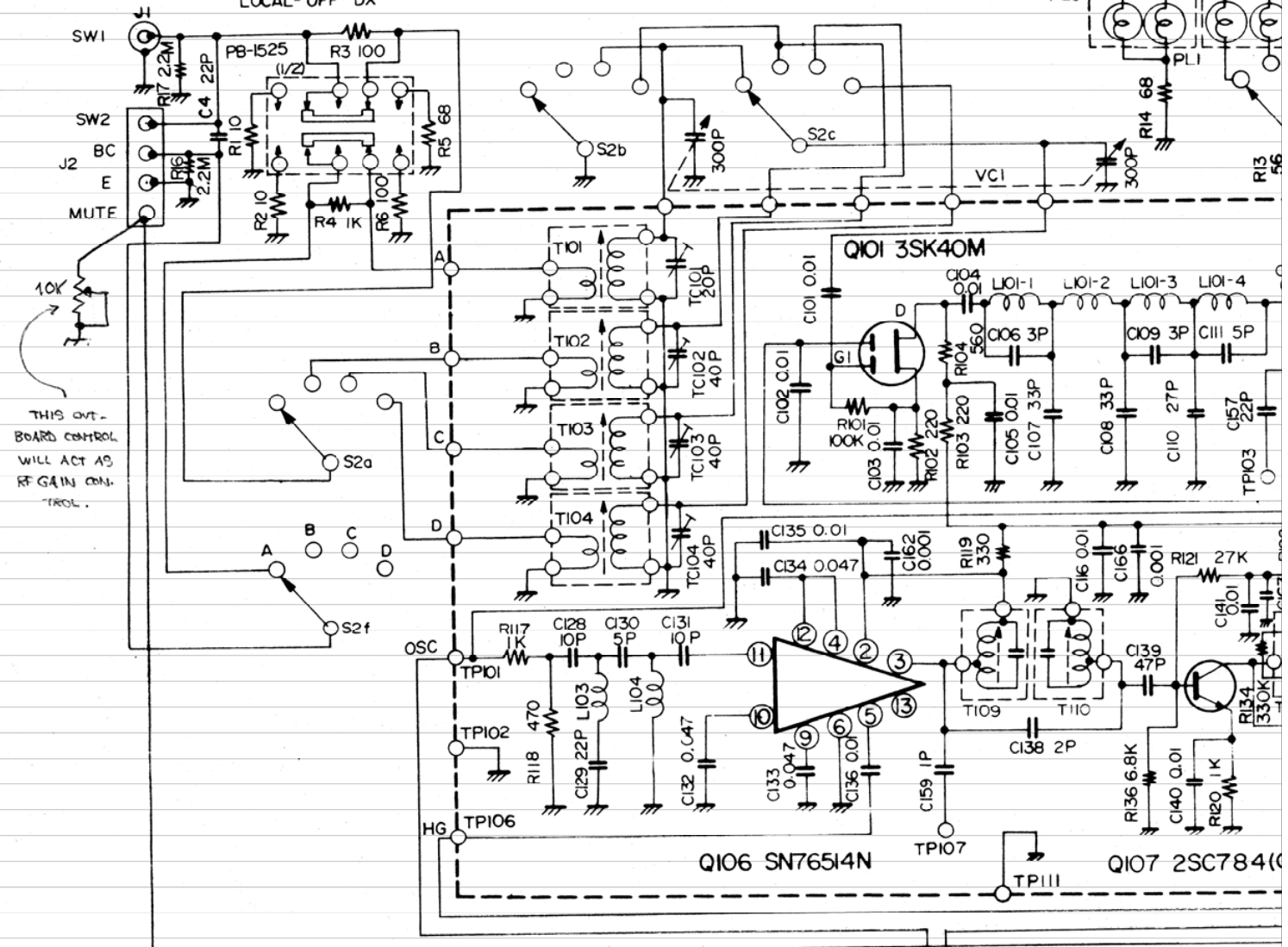

THIS OUT-BOARD CONTROL WILL ACT AS RF GAIN CONTROL.

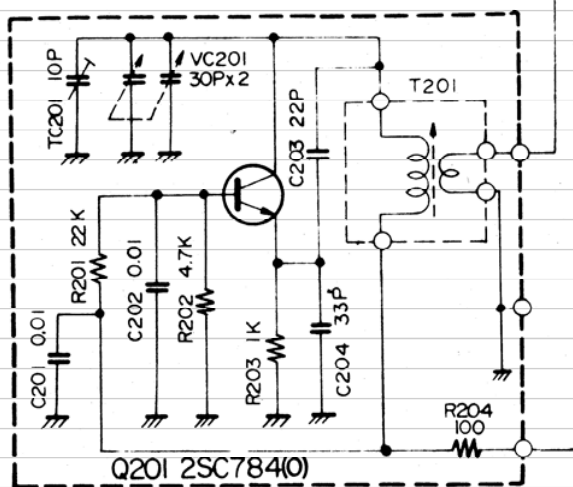

(OSC UNIT PB-1523)

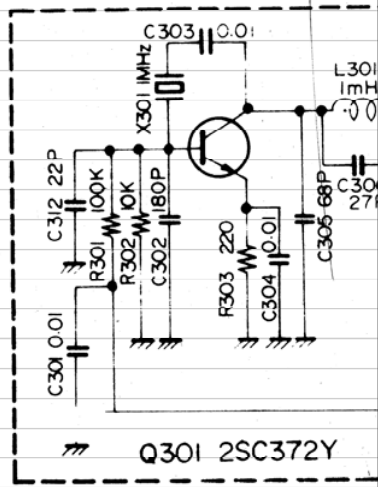

(HG UNIT PB-1524)

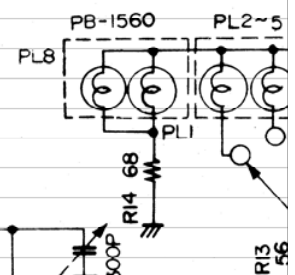

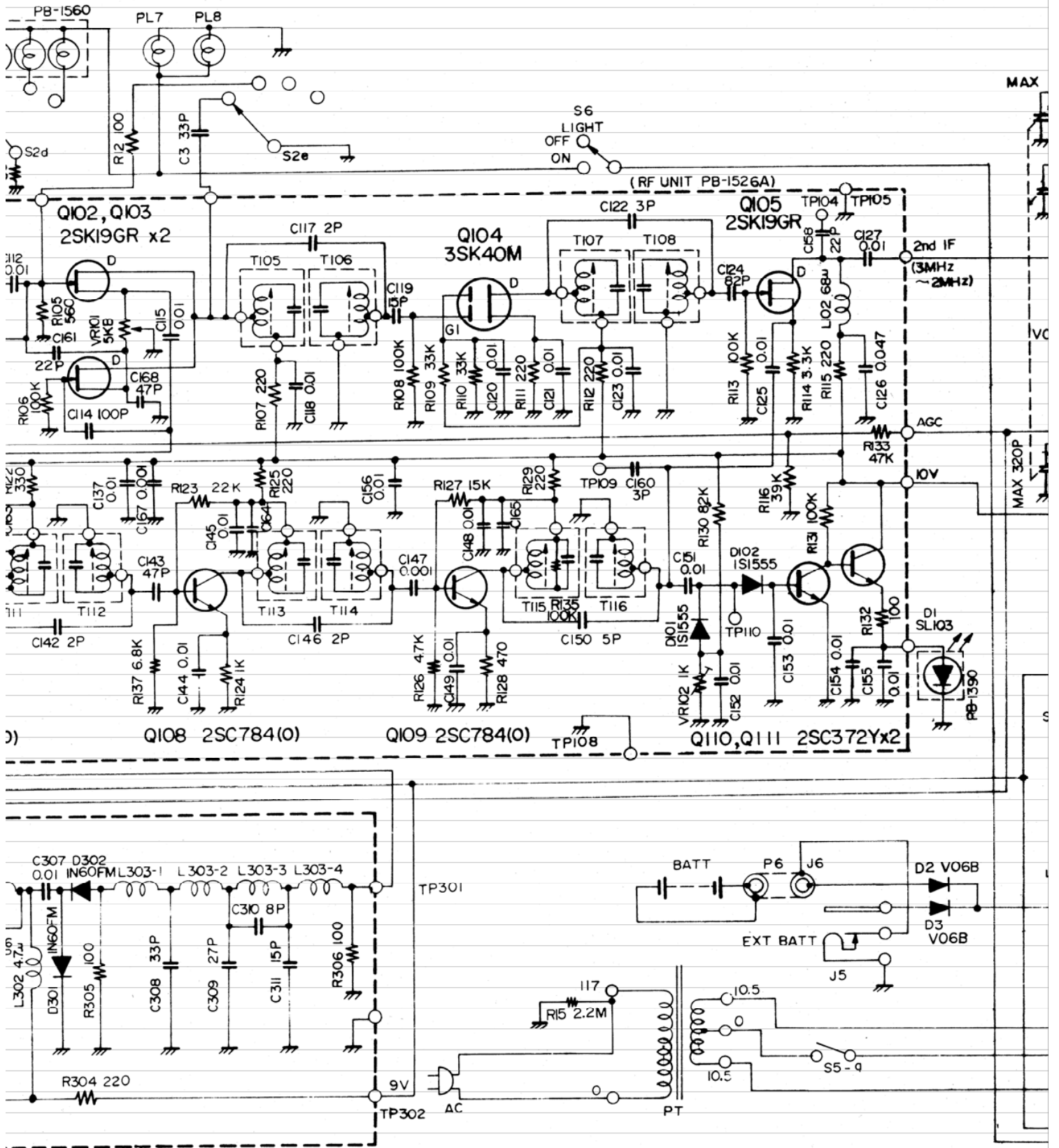

(IF-AF UNIT PB-1528)

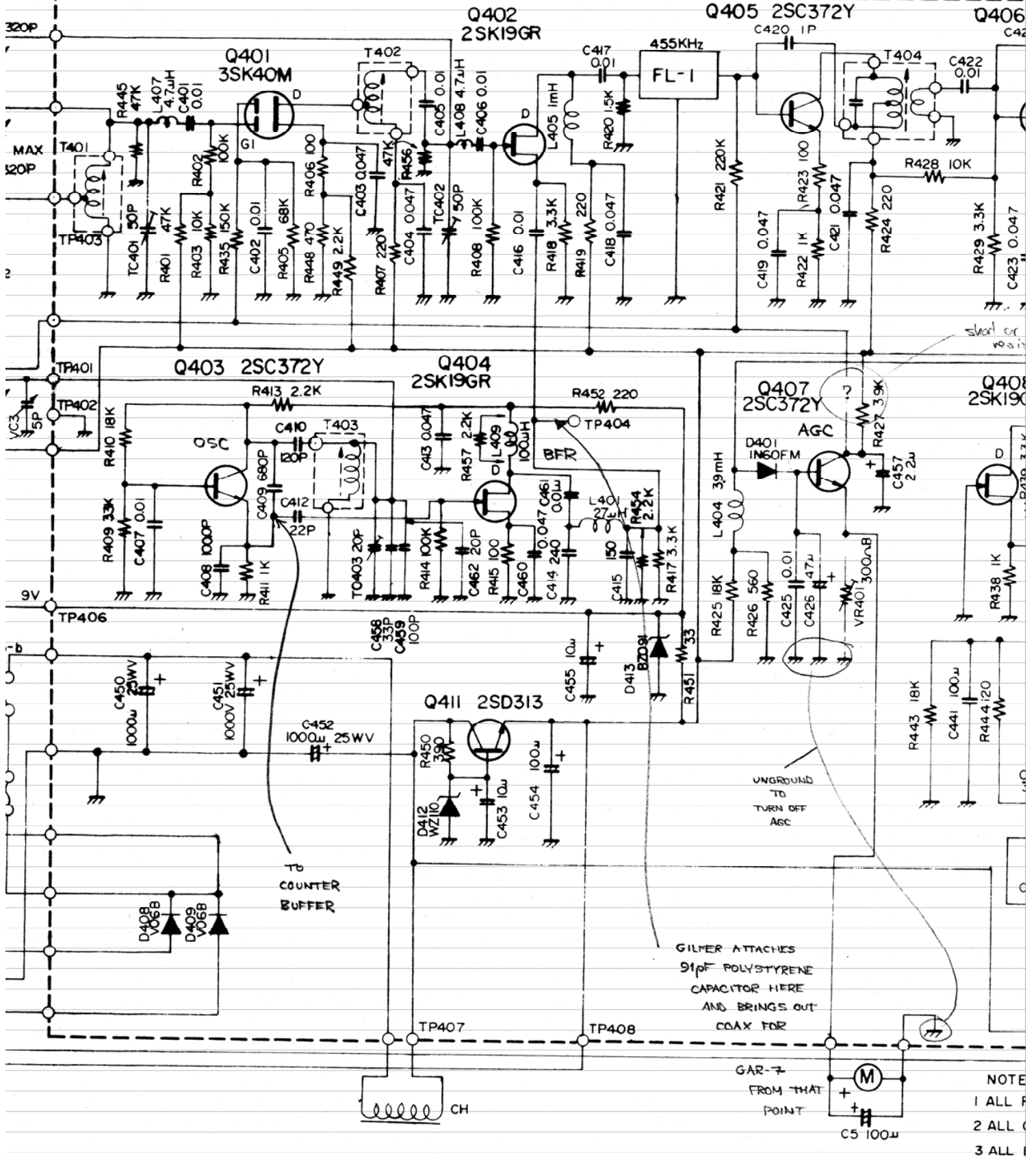

short or
to 0.1

UNGROUND
TO
TURN OFF
AGC

GILMER ATTACHES
91pF POLYSTYRENE
CAPACITOR HERE
AND BRINGS OUT
COAX FOR

GAR-7
FROM THAT
POINT

NOTE
1 ALL F
2 ALL C
3 ALL I

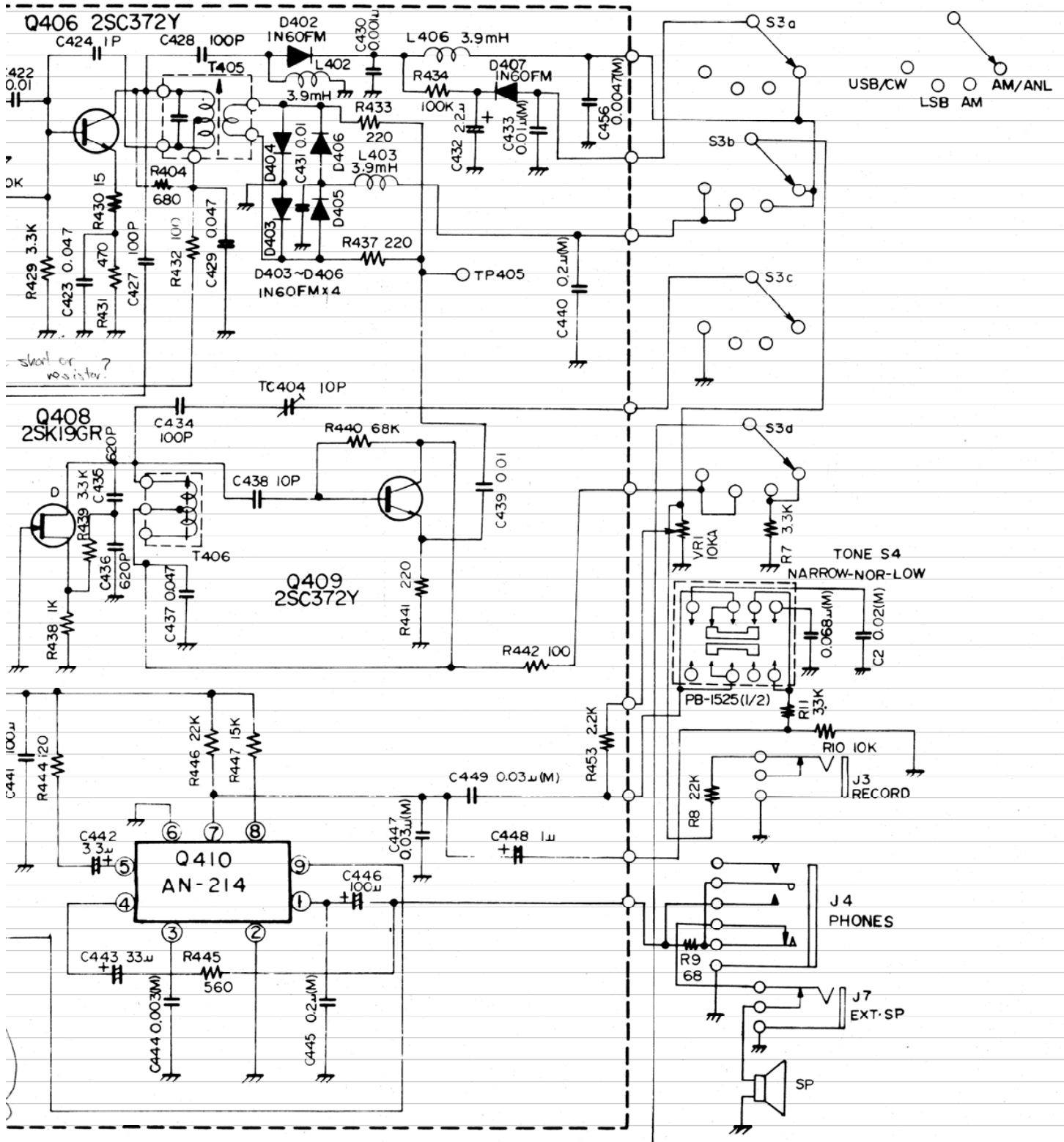

NOTE

- 1 ALL RESISTORS ARE IN 1/4W UNLESS OTHERWISE NOTED.
- 2 ALL CAPACITORS ARE IN μ F UNLESS OTHERWISE NOTED.
- 3 ALL ELECTROLYTIC CAPACITORS ARE 16WV UNLESS OTHERWISE NOTED.

FRG-7
CIRCUIT DIAGRAM

