

USER SERVICING INSTRUCTIONS

21. Introduction

No equipment or installation can be expected to work properly unless it is kept in first class condition by regular servicing, conscientiously carried out. This servicing is the responsibility of the N.C.O. or man who is in direct charge of the equipment and responsible for its operation.

For his guidance, and to ensure that servicing is done, it has been laid down that Signal equipment will be serviced on the task system, and that completion of each task will be recorded on Army Form B2661 - Unit Servicing Log.

This log is reproduced on page 28. Completion of servicing tasks will be recorded by initialling in the spaces provided on the front of the form; all minor repairs and replacements will be recorded on the reverse. The form lasts 24 weeks and replacements should be obtained on indent in the usual way.

22. Suggested Daily Tasks (for Operator)

- (1) Clean the set, including all controls, meter glass, etc.
- (2) Check that all plugs and sockets make good contact and are tightly screwed up.
- (3) Clean the contact surfaces of all aerial rods and check that they fit firmly.
- (4) Inspect the dipole aerial feeder cable for any sign of wear or damage, and ensure that the rubber washers are pushed hard up against the moulded sockets.
- (5) Clean and dry out the microphone and headphones as far as possible, and inspect the cords for signs of wear.

23. Fault Finding (for Operator)

In the event of a fault occurring, the following simple procedure should enable the operator to decide whether the set or one of the accessories is responsible. Any fault must be reported to a superior officer at the earliest opportunity unless it can be cleared without delay.

(1) "BATT VOLTS" meter not reading

- (a) Examine the battery lead carefully and try flexing it to see whether an intermittent connection is made. Examine the plugs and sockets at either end of the lead and see that they are clean and tight; if necessary open up the plug-pins slightly at the battery end of the lead with a pen-knife. If available try a fresh battery and a different battery lead.
- (b) Replace the fuse in the set. If the replacement fuse blows leave the set as it is and report the fault.

(2) **No Receiver Noise**

- (a) Check whether the internal vibrator is working by placing the ear against the set. If nothing can be heard the set is faulty.
- (b) If the normal vibrator hum can be heard disconnect the microphone cord from the set. If this corrects the fault the microphone cord or pressel switch is faulty. If not, the fault is in the set itself.

(3) **Normal Receiver Noise but No Signals (or Weak Signals)**

- (a) If the rod aerial is in use clean all contact surfaces and see that all connections are tight.
- (b) If the dipole aerial is in use disconnect it and try the rod aerial. If this brings in a signal which cannot be heard on the dipole then the latter is faulty. In this case examine the plug and socket connections at either end of the feeder and check the whole feeder carefully for any signs of wear or damage. See that the dipole insulator itself is clean and dry and has not been damaged, and that the rods are making a good connection. If there is no sign of anything wrong externally have the aerial feeder and the wiring in the aerial mounting bracket checked electrically. This can only be done by someone with a test meter, but it is the only certain way of checking the aerial and feeder for continuity.

(4) **Receiver Working but No Sender Output**

Press the microphone pressel switch. If the receiver noise disappears the fault is in the set. If it does not, try a fresh microphone. If the pressel switch still has no effect then again the fault is in the set.

(5) **Sender Output Normal but No Fluctuation when Speaking**

Try a new microphone. If this has no effect the fault is in the set.

24. Brief Technical Description (for R. Sigs. Mechanic)

(1) **Introduction**

The Wireless Set B44 Mk.3 combines an amplitude modulated VHF sender and superhet receiver, both having three fixed (crystal controlled) operating frequencies. These frequencies could be anywhere within the range 60 - 95 Mc/s, but in practice are confined to one of four narrower bands so as to be within the range of a single aerial.

The receiver design is somewhat unusual in that an intermediate frequency of 54 kc/s is used; the 'second channel' frequency is therefore only 108 kc/s removed from the wanted frequency, and is in fact received at a comparable level. The reason for this arrangement is that it allows the problem of second channel interference to be dealt with in the allocation of frequencies; so long as there is a minimum of 200 kc/s separation between the frequencies allotted, there can be no second channel interference between groups of WS B44.

(2) **Receiver**

The block schematic for the receiver is given in Fig. 12, and it can be seen that the basic arrangement is that of a straight-forward superhet with one R.F. and two I.F. stages. V2 is an

electron-coupled oscillator operating at one sixth of the frequency (signal frequency + 54 kc/s) actually required, and so it is necessary to select the sixth harmonic for use in the mixer stage (V3). This harmonic is so close in frequency to the signal that it can be selected by a circuit tuned to the signal frequency, and so the anode circuit of V1 is used for V2 anode also. (i.e. the two anodes are connected together). The same tuned circuit selects the required harmonic from V2 and passes it, with the signal from V1, to the mixer (V3).

The three alternative crystals for V2 are selected by means of the REC CHANNEL switch, which is mechanically linked with the ganged condensers for the receiver. This is therefore tuned automatically in accordance with the crystal selected (provided the mechanism has been correctly adjusted in the first place).

The I.F. amplifier (V4 - 5), although operating at the unusually low frequency of 54 kc/s, is required to have a bandwidth of 50 kc/s in order to accommodate errors arising from permissible crystal inaccuracies at either receiver or distant sender. The design is therefore somewhat specialised.

The detector and A.G.C. stages (V6) are conventional, and the noise limiter (V7 diode section) is of the series type which blocks both signal and noise for the duration of any noise impulses of sufficient amplitude. The volume control is between the detector and the A.F. amplifier (V7 triode section), which is transformer-coupled to the push-pull output stage (V8 - 9). Grid bias for this stage is supplied from an auxiliary output from the power unit. The loudspeaker and headphones are both connected to the same winding of the output transformer, but the loudspeaker may be disconnected by means of the L.S. switch; there is also an attenuator in the headphone circuit to reduce the signal to headphone strength.

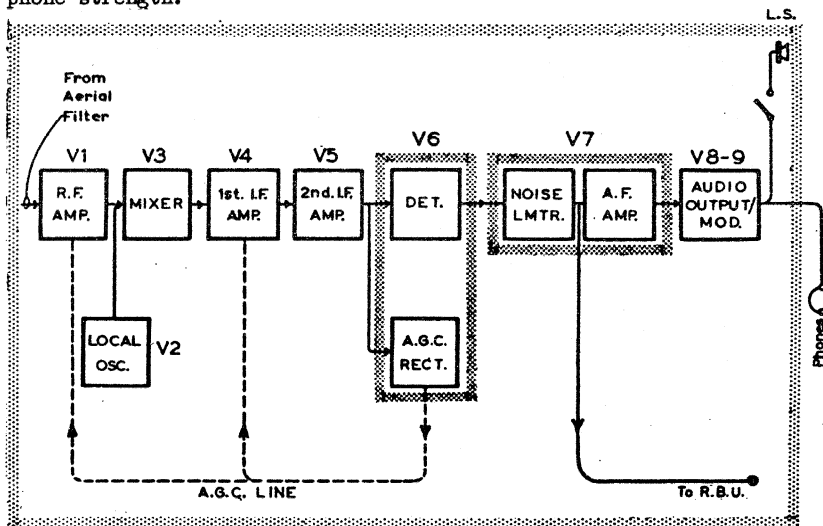

Receiver Block Schematic

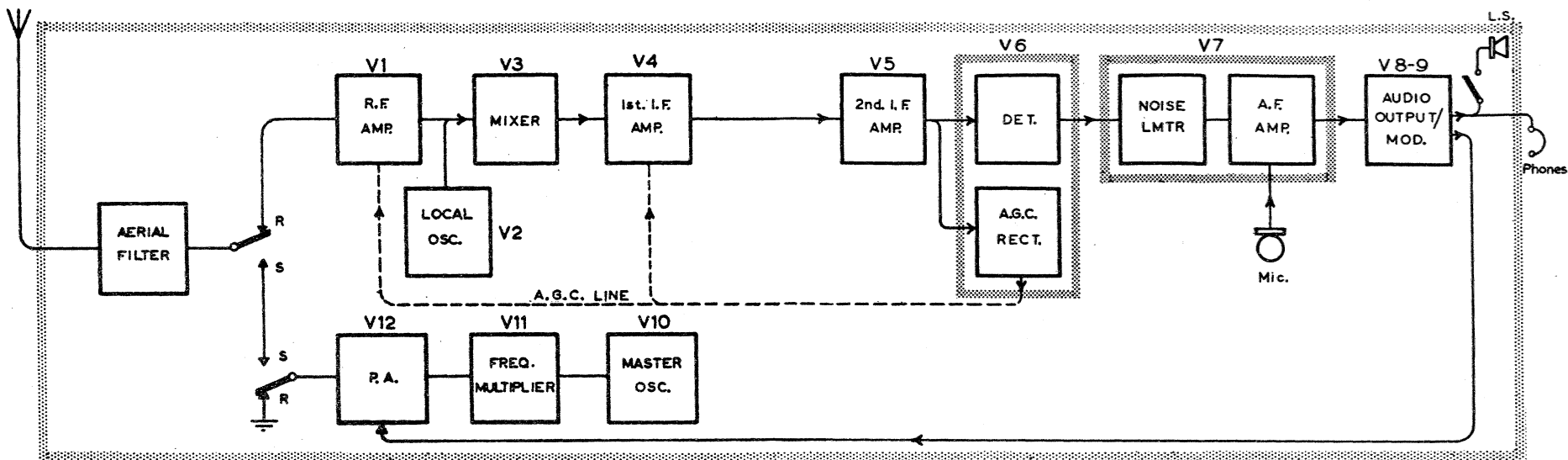

Fig. 13 Complete Block Schematic

(3) Sender

The sender block schematic is included in Fig.13, where it will be seen that the A.F. amplifier and push-pull output stages (V7 and V8 - 9) of the receiver are used as the microphone amplifier and modulator stages of the sender. Anode modulation is employed, and is obtained from a separate winding on the push-pull output transformer.

The master oscillator (V10), like V2, is an electron-coupled oscillator operating at one sixth of the required frequency. In this case, however, the sixth harmonic (which is used as the radiated frequency) is selected in two stages; the anode circuit of V10 is tuned to select the third harmonic and this is doubled in the frequency multiplier stage (V11).

The power amplifier (V12) is driven from a tapping in the anode circuit of V11, and, since the level of drive is such as to cause grid current to flow, it receives grid bias from the rectified portion of the drive voltage. In addition there is a fixed bias supply from the vibrator unit and there is also a cathode bias resistor, and the two latter sources prevent damage to the valve in the event of a loss of bias resulting from drive failure.

(4) Power Supply Unit

The vibrator unit employs a self-rectifying type of vibrator for the H.T. supply but the bias voltage is obtained from a separate winding on the vibrator transformer and is rectified by means of a metal rectifier. The same bias supply is used for the sender power amplifier stage (V12) and for the receiver audio output/sender modulator stage (V8 - 9).

(5) Aerial Filter

The aerial filter is permanently connected in the aerial circuit and, as shown in the overall block schematic in Fig. 13, it operates on both send and receive. It is a band-pass filter designed to reject all frequencies outside the range 60 - 95 Mc/s over which the set may be used. In this way spurious responses due to oscillator harmonics, etc., are eliminated.

(6) Send/Receive Switching

This is performed entirely by two relays which are energised from the 12V battery supply when the microphone pressel switch is pressed. They function as follows:-

Relay 1 (two change-over contacts)

Switches the aerial connection to sender or receiver; when the receiver is in use, the sender output is earthed.

Relay 2

Contact 1. Switches the H.T. supply to sender or receiver.

Contact 2. Disconnects loudspeaker on Send, reduces the bias on V8-9 and also reduces the headphone signals to a comfortable level for side-tone.

Contact 3. Connects a damping resistor in place of the microphone when on Receive.

Contact 4. Completes the microphone circuit when on Send.

(7) Re-Broadcast Unit

The circuit diagram for the trade pattern unit - Units Re-Broadcast No. 1 - is as shown in Fig. 14. To operate the Send/Receive relay in the sender, either the Normal/Re-Broadcast switch must be at 'Re-Broadcast' or the relay contact RLA2 must be closed (i.e. relay RLA must be operated). Relay RLA operates whenever the microphone pressel switch is pressed, and its remaining contact (RLA1) disconnects the Re-Broadcast circuit and connects the microphone for direct transmission. Thus the microphone pressel has priority over the Normal/Re-Broadcast switch.

When the microphone pressel is released contact RLA2 opens, and if the Normal/Re-Broadcast switch is at 'Normal' the sender is switched off. If this switch is at 'Re-Broadcast' the sender is held on when RLA2 opens, and at the same time RLA1 restores the Re-Broadcast circuit.

The jack for Receivers Headgear No. 2 was originally provided to allow the B44 Mk.2 headphones to be used, but this requirement now seems unlikely to materialise.

The circuit diagram for the R.E.M.E pattern unit is also in Fig. 14, and it will be seen that with this unit the change-over from Re-Broadcast to direct transmission (or vice-versa) can only be accomplished by operating the Normal/Re-Broadcast switch.

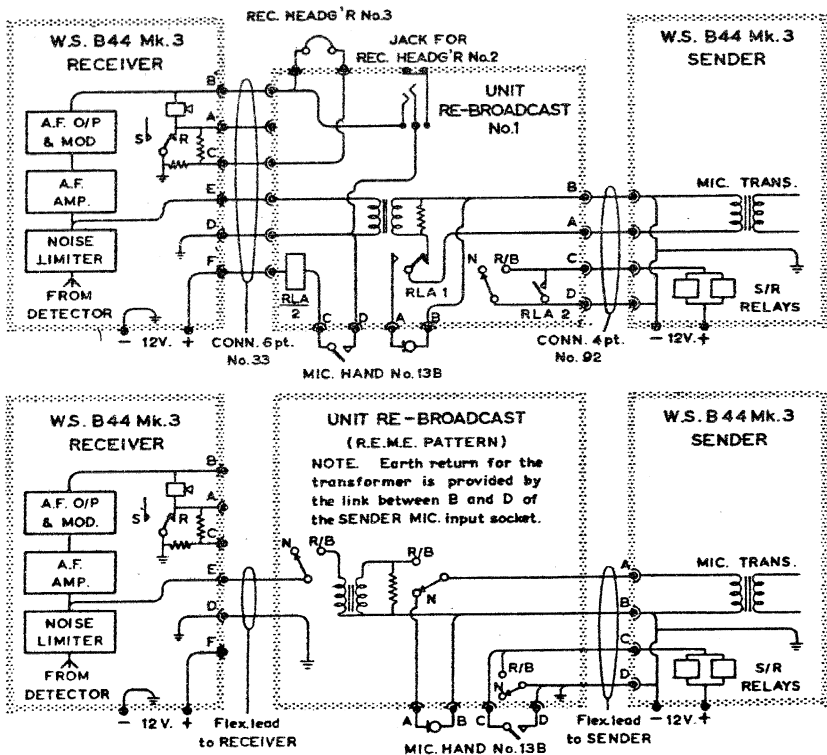
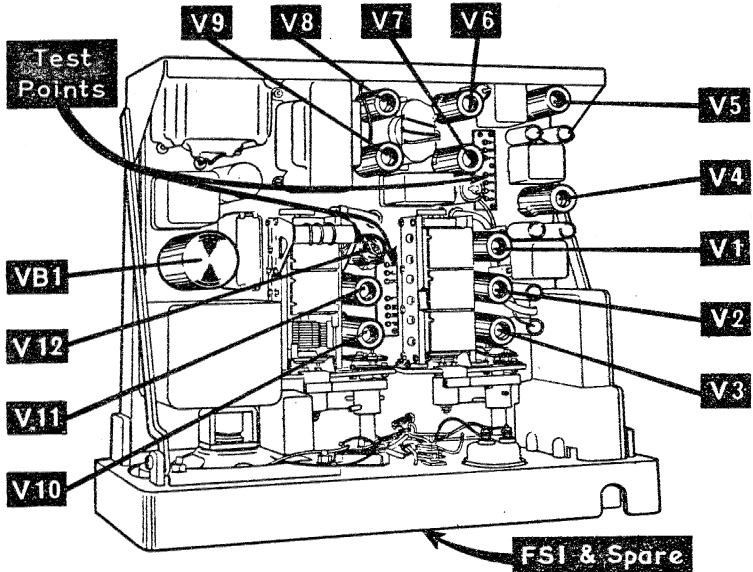

Fig.14 Circuit Diagrams of Re-Broadcast Units

25. Valve Data

The function and location of each valve is shown below, and a list of equivalent commercial type numbers is given. No data is included for crystals, because the user is not provided with spares.



Circuit Ref.	Catalogue No.	Function
V1	CV 138	Receiver R.F. Amplifier
V2	CV 138	" Local Oscillator
V3	CV 138	" Mixer
V4	CV 138	" 1st I.F. Amplifier
V5	CV 138	" 2nd I.F. Amplifier
V6	CV 140	" Detector & A.G.C. Rectifier
V7	CV 137	{ Sender A.F. Amplifier
V8 - 9	CV 136	{ Receiver Noise Limiter & A.F. Amplifier
		{ Sender Modulator } Push-Pull
		{ Receiver Audio Output } Stage
V10	CV 416	Sender Master Oscillator
V11	CV 416	" Frequency Multiplier
V12	CV 2129	" Power Amplifier
VB 1	Z 730008	Self-Rectifying Vibrator for power supply
FS 1	Z 590113	7A battery input fuse

CV No.	Commercial Equivalents					
138	EF91	Z77	6AM6	6F12	SP6	HP6
140	EB91	D77	6AL5	6D2	DD6	
137	EAC91					
136	EL91	N77	6AM5	V887		
416	6F17					
2129	5763					

26. Fault Finding Checks (for R. Sigs. Mechanic)

The user mechanic's responsibility for clearing faults in the B44 Mk. 3 will normally be confined to changing valves or the vibrator; the following notes therefore only contain information appropriate to such tasks. It must be remembered, in connection with valve changes, that if either V1, V2, V3, V10, V11 or V12 are replaced the set will not necessarily be restored to full efficiency without some re-alignment. It should, therefore, be returned to workshops for this to be done at the earliest opportunity, accompanied by a note of the change that has been made.

It is suggested that, in order to locate the faulty valve, the mechanic checks the following points in the order given:-

(1) L.T. Voltages

The minimum acceptable L.T. voltage is 10.8V.

(2) Valve Heaters

The glow from the heaters can invariably be detected somewhere in the envelope, but not always when the screening can is in position. Note from the heater circuit (Fig. 15) that if V12 heater fails, both V10 and V11 will be put out of action.

If any valve envelope has a milky white appearance it is probably cracked, and should be replaced forthwith.

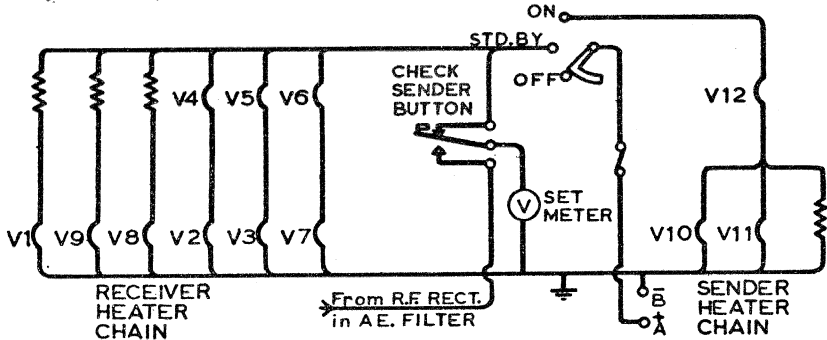

Fig. 15 Heater Circuit

(3) H.T. and Bias Voltages

Check against table (opposite) at points A, B, E, F, G, H and N.

- If no voltage at A, change vibrator. If still no voltage, report.
- If voltage correct at A, but absent at any other point, report.

(4) Audio Stages

Switch to Stand-By, press microphone pressel switch and speak. Loudspeaker should operate at good volume and there should be strong tendency to 'howl'.

- If weak output is suspected, re-check with V8 and V9 operating individually. Replace either valve if weak.
- If there is no output, check voltage at point C. Replace V7 if the figure obtained is appreciably different from that given in the table opposite.

(5) Receiver Noise and Signals

Check for receiver noise with no aerial. If normal, check for signals with aerial connected.

- If no noise, try V3, V4, V5 and V6.
- If noise and/or signals are weak, try V1 or V2.

(6) Sender M.O. Grid Current

Check current from point P to chassis on all three frequencies.

- If low on all three frequencies, replace V10.
- If low on one frequency only, report. (Probably a faulty crystal).

(7) Frequency Doubler and P.A. Stages

Check at the following points:-

- L If down, replace V11.
- M If down, suspect trimming. Report.
- J If down, replace V12.
- H - K If down, suspect trimming. Report.

(8) Aerial Current and Modulation

With aerial connected press microphone pressel switch and speak or whistle. Normal aerial current should be obtained and indication should fluctuate with modulation.

- If aerial current and/or modulation are not indicated on set meter, report.

27. Readings at Test Points

The following table gives typical readings taken with an Avometer at the two rows of test points mounted on the chassis. For D, H, M and P the chassis is positive; for H-K point H is positive and K is negative; for all other points chassis is negative.

Test Point	Measurement	Meter Range	Sender OFF	Sender ON
A	Main H.T.	500V	270/310V	240/260V
B	V8 and 9 H.T.	500V	270/310V	240/260V
C	V7 triode cathode	5V	1.0/1.2V	0.7/1.0V
D	V6 detector o/p	2.5mA	-20/30µA	-
E	V4 and 5 H.T.	500V	210/230V	-
F	V1 and 3 H.T.	250V	145/175V	-
G	Receiver H.T.	500V	275/295V	-
H	Grid bias (V12)	25V	-3.9/-4.1V	-6.9/-8.9V
H - K	V12 grid current	2.5mA	-	1.1/1.7mA
J	V12 cathode	5V	-	1.2/1.6V
L	V11 cathode	25V	-	7.0/9.5V
M	V11 grid current	2.5mA	-	-0.25/-0.5mA
N	V10 H.T.	250V	-	210/230V
P	V10 grid current	2.5mA	-	-0.35/-0.55mA

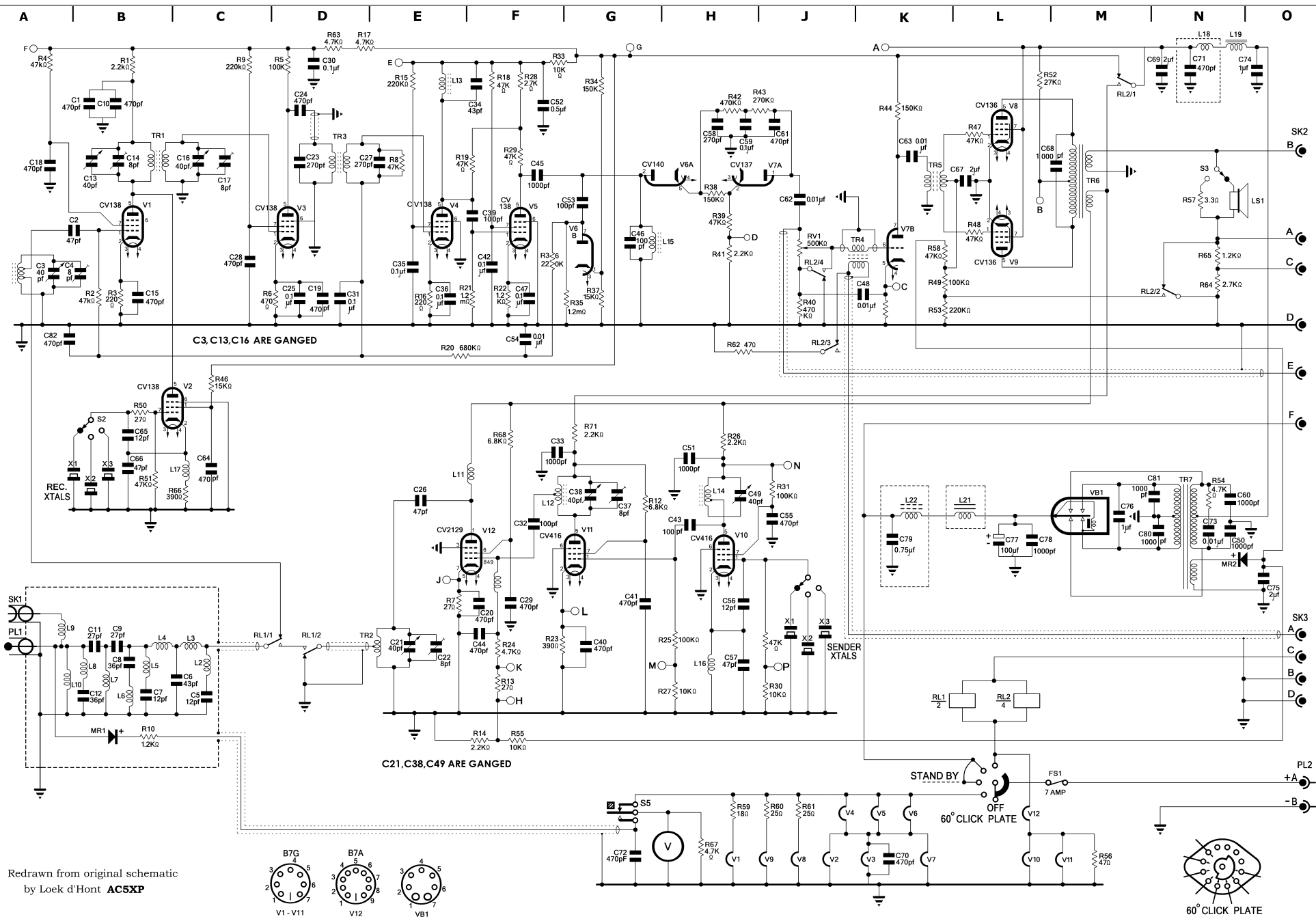

Redrawn from original schematic
by Loek d'Hont AC5XP

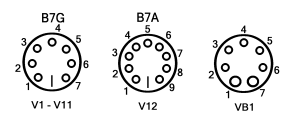

- Circuit diagram WS-B44 Mk3

