

# COMMUNICATIONS RECEIVER

*Type CR.100*

TECHNICAL HANDBOOK

No. T 1868/1

NOTE.—The photographs, drawings and letterpress used in this handbook are copyright

*Marconi*

**MARCONI'S WIRELESS TELEGRAPH COMPANY LIMITED**

*Head Office: Marconi House, Chelmsford · Telephone: Chelmsford 3221 · Telegraphic Address: Expanse, Chelmsford*

CONTENTS,		PAGES
DATA SUMMARY .. .. .		vii
SECTION 1. GENERAL CHARACTERISTICS.		
Salient Features .. .. .		1
SECTION 2. OPERATION.		
Preliminary Adjustments for Operating the Receiver .. .. .		2
General Notes on Operating the Receiver .. .. .		3-4
Adjustment of Beat Frequency Oscillator .. .. .		3
Use of Pass-band Switch .. .. .		3
Use of A.V.C. .. .. .		3
Use of Gain Controls .. .. .		4
"Off" Position of Operational Switch .. .. .		4
Use of Logging Scale .. .. .		4
SECTION 3. TECHNICAL DESCRIPTION.		
(A) Electrical :		
Circuit Arrangement .. .. .		5
Aerial Input, Signal Frequency Circuits and Mixer .. .. .		5
Oscillator and Intermediate Frequency Circuits .. .. .		6
Signal Detector and A.V.C. Rectifier .. .. .		6
Beat Frequency Oscillator .. .. .		6
Audio Frequency Amplifier .. .. .		7
Power Supplies .. .. .		7
Controls .. .. .		7
Frequency Band .. .. .		7
Tuning and Calibration .. .. .		7
Logging Scale .. .. .		7
Selectivity Control .. .. .		8
H.F. Gain Control .. .. .		8
L.F. Gain Control .. .. .		8
Outputs .. .. .		8
Operational Switch .. .. .		8
Side-Tone Facility .. .. .		8
Valve Complement with Service Equivalent Types and Substitutes .. .. .		9
(B) Mechanical .. .. .		10
SECTION 4. PERFORMANCE.		
Overall Sensitivity—Table 1 .. .. .		11
Automatic Volume Control .. .. .		11
Selectivity of Signal Frequency Circuits. Image Attenuation .. .. .		11
Image Signal Protection—Table 2 .. .. .		12
Selectivity of Intermediate Frequency Circuits—Table 3 .. .. .		12
Permitted I.F. Bandwidth Tolerances—Table 4 .. .. .		12
Audio Frequency Response .. .. .		12
Overall Fidelity Response .. .. .		12

## SECTION 5.

PAGES

## MAINTENANCE AND SERVICING.

Packing and Unpacking .. .. .	13
Cleaning and Lubricating .. .. .	13
General Care .. .. .	13
Checking Valve Performance and Changing Valves .. .. .	13-14
Voltage and Current Check—Table 5 .. .. .	15
Hints on Tracing Faults .. .. .	16
Resistance Check—Table 6 .. .. .	17
Standard Colour Code for Resistances .. .. .	18
Connections to Octal Valve Holders .. .. .	18

## Detailed Hints on Fault Locating :

(A) Audio Frequency Circuit Faults .. .. .	19
(B) Intermediate Frequency Circuit Faults .. .. .	19
(C) Signal and Oscillator Frequency and Mixer Faults .. .. .	19-20

## (D) Miscellaneous Electrical Faults :

A.V.C. and Signal Diode Faults .. .. .	20
Failure of the B.F.O. .. .. .	20
Mis-alignment of the B.F.O. .. .. .	20
Failure or Partial Failure of the Heater and Dial Lamp Circuits .. .. .	21
Failure of Loudspeaker Output .. .. .	21
Instability and Noise .. .. .	21
Instability when tuned to 420 kc/s Band 2 .. .. .	21
Instability when Signal Generator is connected to Dipole Terminals .. .. .	21
L.F. Instability on 100 c/s Pass-band .. .. .	21

## (E) Miscellaneous Mechanical Faults :

Slow Motion Drives .. .. .	21
Aerial Trimmer Condenser .. .. .	21
Broken P.K. Screws .. .. .	21
Broken Valve Holder Sockets .. .. .	21
Broken Cords .. .. .	21
Fitting new Band-change Cord on early models having a single pulley .. .. .	22
Fitting new Band-change Cord on models having 5-wheel pulley .. .. .	22-23
Fitting new Pointer Cord on models having an inspection hole in front plate of Slow Motion Drive Assembly .. .. .	23
Fitting new Pointer Cord on models having no inspection hole in front plate of Slow Motion Drive Assembly .. .. .	23-24

## Circuit Alignment and Tests :

Use of Output Meter .. .. .	24
Using A.C. Milliammeter and Resistance .. .. .	24
Using A.C. Avometer as an Indicator .. .. .	24
Adjustment of L.F. Filter .. .. .	24-25
Checking the Response of L.F. Filter .. .. .	25
Checking the Response of Audio-Frequency Amplifier .. .. .	25
Checking the Gain of Audio-Frequency Amplifier .. .. .	25

	PAGES
Alignment of I.F. Circuits and Beat Frequency Oscillator .. .. .	25
Laboratory Method of I.F. and B.F.O. Alignment (using the special units required) .. .. .	25-28
Method of Connection .. .. .	26
Preliminary Adjustment of I.F. Circuits .. .. .	26-27
Lining-up I.F. Circuits to the Crystal Resonator .. .. .	27
Lining-up the Beat Frequency Oscillator (B.F.O.) .. .. .	28
I.F. Bandwidth Check .. .. .	28
Workshop Method of I.F. and B.F.O. Alignment (for use when special apparatus is not available) .. .. .	28-29
Method of Connection .. .. .	29
Lining-up I.F. Circuits .. .. .	29
Re-tuning I.F. 5 Transformer .. .. .	29
Emergency Method of I.F. Alignment (not covering Crystal Filter adjustments)	29
Simple Method for Lining-up B.F.O. without Test Apparatus .. .. .	30
Measurement of I.F. Sensitivity, Maximum Gain :	
Apparatus required and Method of Connection .. .. .	30
Grid Voltage per Stage for 100 mW. Output .. .. .	30
Measurement of I.F. Sensitivity, Signal to Noise Ratio .. .. .	30
Checking the Relative Sensitivity for Different Bandwidths .. .. .	30
Adjustment of 1st Oscillator .. .. .	31
Lining-up Signal Frequency Circuits .. .. .	31-32
Sensitivity and Image Protection Check .. .. .	32
Detune Ratio Test—Table 7 .. .. .	32-33
Maximum Noise Levels—Table 8 .. .. .	33
Electrical Data of Components :	
L.F. Filter Sub-Assembly .. .. .	34
Output Transformer .. .. .	34
Mains Transformer .. .. .	34
Smoothing Chokes .. .. .	34
Electrolytic Condensers .. .. .	34
Gain Controls .. .. .	35
Resistors .. .. .	35
Condensers .. .. .	35
Electrical Specification of H.F. Coil Assembly—Table 9 .. .. .	35
Electrical Specification of I.F. and B.F.O. Assemblies—Table 10 .. .. .	36
Main Tuning 4 Gang Condenser. Angle Capacity Law—Table 11 .. .. .	36
Main Tuning 4 Gang Condenser. Logging Scale—Capacity Law—Table 12 .. .. .	37

## SECTION 6.

### INSTALLATION.

Bench or Rack Mounting .. .. .	38
Connections for A.C. Supply .. .. .	38
Connections for H.T. and L.T. Battery Working .. .. .	38
Connections when using Rotary Converter Unit .. .. .	39
Aerial Connections .. .. .	39
Side Tone Facility (Type CR.100/2 only) .. .. .	39

## SECTION 7.

### COMPONENT PARTS LISTS AND DIAGRAMS.

Component Parts—Receiver .. .. .	40-43
Component Parts—Rotary Converter .. .. .	44

## INDEX OF DIAGRAMS.

TITLE.	FIG.	PAGE
Audio-frequency Response Curves .. .. .	6	49
A.V.C. Response Curves .. .. .	4	49
Band-change Cord .. .. .	11	51
Chassis—Top of .. .. .	20	53
Chassis—Underneath of .. .. .	21	53
Coil Assembly, Aerial Section .. .. .	22	55
Coil Assembly, H.F. Section .. .. .	23	55
Coil Assembly, Mixer Section .. .. .	24	57
Coil Assembly, Oscillator Section .. .. .	25	57
Ganging Tool .. .. .	12	26
H.T. Circuits .. .. .	WZ.1948/C	51
I.F. Response Curves.. .. .	5	49
I.F. Response Curves (Oscilloscope) .. .. .	13 & 14	49
Logging Scale .. .. .	2	4
L.F. Filter Response Curves .. .. .	7	49
Overall Fidelity Response Curve .. .. .	8	49
Panel Controls .. .. .	1	2
Rear Terminals of Type CR.100 and CR.100/4 Receivers .. .. .	17	51
Rear Terminals of Type CR.100/2 Receiver .. .. .	18	51
Rear Terminals of Type CR.100/5 Receiver .. .. .	19	51
Receiver—Diagram of Connections .. .. .	WZ.1943	47
Rotary Converter and Battery—Diagram of Connections .. .. .	WZ.1960/C	45
Socket Wiring for A.C. Mains .. .. .	15	38
Socket Wiring for Independent Supplies .. .. .	16	38
Valve Holder, underside .. .. .	10	18
Valve Positions, plan showing .. .. .	3	9
Valve Testing Points, plan of underside .. .. .	9	14

## DATA SUMMARY.

TYPE .....	Self-contained Communications Receiver of superheterodyne type with A.V.C. for use on CW or Phone reception.
FREQUENCY RANGE .....	60 kc/s to 420 kc/s 500 kc/s to 30 Mc/s } in 6 bands.
SUPPLY REQUIREMENTS .....	(A) <i>D.C. Supplies.</i> (1) H.T. and L.T. Batteries. H.T. 250 volts 100 mA. reduced to 160 volts 60 mA. if desired. L.T. 6 volts 4 Amps. or (2) Battery and Rotary Converter. 6 volts 8 Amps. total supply. (B) <i>A.C. Supplies.</i> 200/250 volts 50 c/s. 85 watts.
RECEIVER INPUT .....	100 ohms. balanced or unbalanced, or high impedance aerial.
SENSITIVITY .....	For 20 db signal-to-noise ratio on C.W. (Average Receiver) 60 kc/s to 11 Mc/s. 1 to 2 $\mu$ V. 11 Mc/s to 30 Mc/s. 1.5 to 4 $\mu$ V.
VALVES .....	See page 9.
RECEIVER OUTPUTS .....	Loudspeaker (3 ohms or 1,000 ohms) 2 watts maximum, approx Line (600 ohms) of the order of 2 mW. Phoncs (high or low resistance) depending on impedance of Phones and Receiver Edition.
MODIFIED EDITIONS .....	A number of Editions exist carrying modifications to suit the needs of various Services, the principal models being CR. 100. CR. 100/2. CR. 100/4 and CR. 100/5.
WEIGHT AND DIMENSIONS .....	Dimensions overall : Width 16 in. : Depth 16 $\frac{1}{2}$ in. : Height 12 $\frac{1}{4}$ in.. Weight 82 lbs.

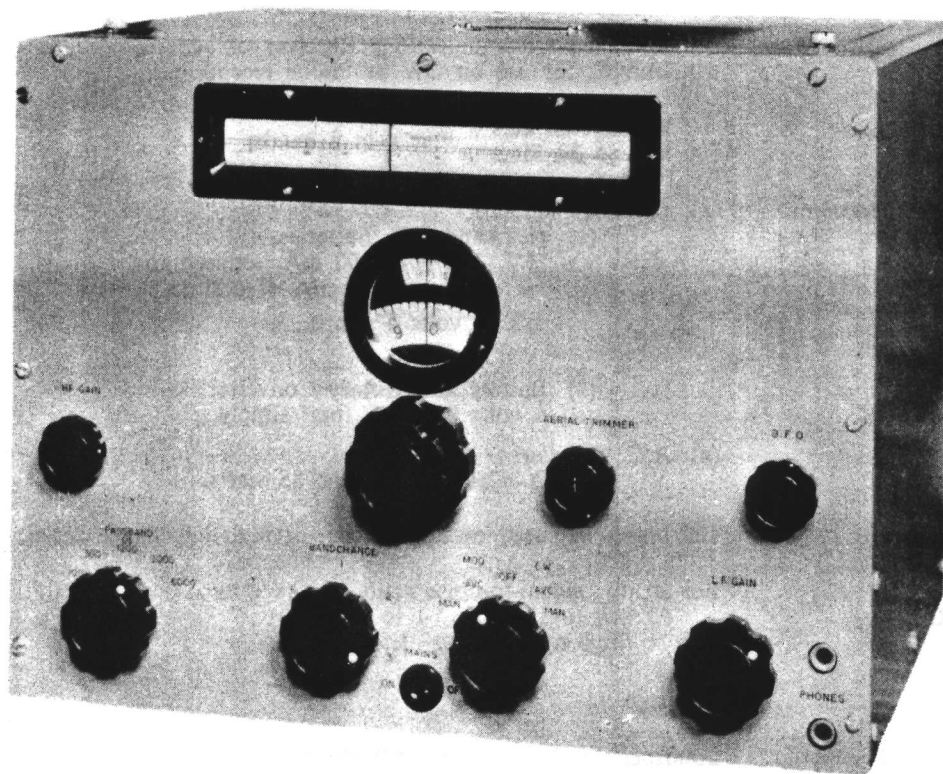

RECEIVER TYPE CR. 100/2.

- |                                     |                                       |
|-------------------------------------|---------------------------------------|
| A. Fine and Coarse Tuning Controls. | E. H.F. Gain Control.                 |
| B. Band-Change Switch.              | F. L.F. Gain Control.                 |
| C. Aerial Trimmer.                  | G. Beat Frequency Oscillator Control. |
| D. Pass-band Switch.                | H. Operational Switch.                |

**MARCONI**  
**TYPE CR. 100 SERIES**  
**OF RECEIVERS**

SECTION 1.

GENERAL CHARACTERISTICS.

The receiver when operated from an A.C. supply is self-contained. It combines extreme flexibility with high sensitivity and selectivity, and is equally suitable for providing good quality speech output at loudspeaker level as for the reception of C.W. signals under difficult conditions. It may be operated from Batteries or Rotary Converter if desired.

**SALIENT FEATURES.**

**(1) Sensitivity and Image Protection.**

By the use of two stages of high frequency amplification preceding the mixer, great sensitivity and protection against interference on image frequencies are obtained. Image protection is of the order of 30 db. (30 to 1) at 28 Mc/s, and is greater than 60 db. (1,000 to 1) on frequencies below 11 Mc/s.

**(2) Selectivity (Variable).**

Protection against adjacent channel interference is made high by the use of a crystal gate and three stages of Intermediate Frequency Amplification employing coupling circuits of high Q. A low frequency filter preceding the output valve can be used to reduce further the pass-band width to 100 cycles if desired.

**(3) Automatic Volume Control.**

A.V.C. may be used on both phone and C.W. reception, and a suitable delay voltage and time constants have been provided.

**(4) Calibration and Logging Scales.**

Easy tuning and accurate re-setting to any known frequency are ensured by the illuminated scale calibrated directly in frequency, and the separate Logging Scale which has a high discrimination and is driven from the same control spindle.

**(5) Side-Tone Facility.**

Facilities are provided on certain models for muting the receiver during transmissions from associated equipment.



SECTION 2.  
OPERATION.

Assuming that the receiver has been correctly installed the following instructions give all the information essential for its correct use. Most of this information is also to be found in concise form on a bound card supplied with later receivers.

Fig. 1. The numbered controls correspond to the numbers in brackets below.

**PRELIMINARY ADJUSTMENTS FOR OPERATING THE RECEIVER.**

- (1) MAINS SWITCH to ON. Dial lamps should light up. Allow a few minutes for warming up, and longer if possible. This switch is not in circuit if operating the receiver from batteries.
- (2) OPERATIONAL SWITCH to "C.W.—A.V.C."
- (3) PASS-BAND SWITCH to "3,000 c/s."
- (4) H.F. GAIN at or near maximum clockwise.

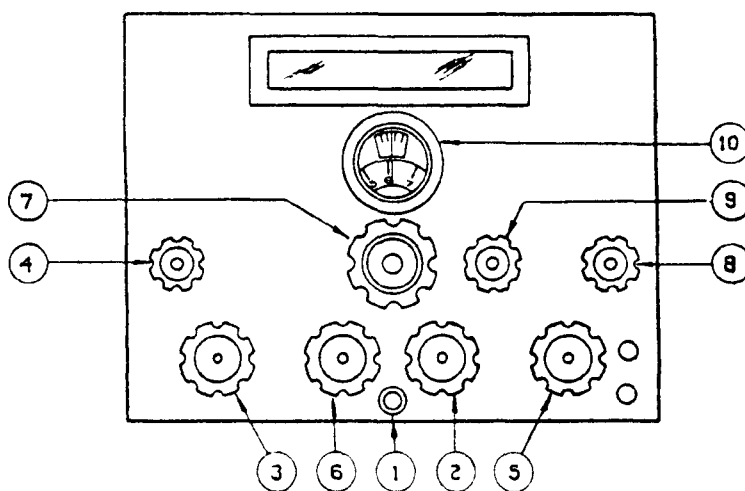

Fig. 1. Panel Controls.

- (5) L.F. GAIN adjusted to give a comfortable level of noise in phones or loudspeaker.
- (6) BAND-CHANGE SWITCH to the frequency band required.
- (7) TUNING. Adjust the pointer on the calibration scale to the desired frequency by the larger tuning knob, and rock the smaller knob *slowly*, about one revolution on either side, until the carrier of the wanted station is heard. If R/T (telephone) is to be received change the Operational Switch (2) to "MOD—A.V.C." and retune slightly if necessary.
- (8) B.F.O. Do not use the B.F.O. for fine tuning. When the receiver has warmed up (15 minutes or longer if convenient) this should be adjusted and thereafter not varied, except for occasional checking. See General Notes below.
- (9) AERIAL TRIMMER. If signals are weak this should be adjusted for best results. The optimum setting for any frequency in use is found by reducing the H.F. Gain to a level at which strong incoming signals do not swamp the amplifiers or work the A.V.C., and then adjust for maximum signal strength or maximum 1st circuit noise. The setting is more critical and important at the high frequency end of the band in use.

## GENERAL NOTES ON OPERATING THE RECEIVER.

### Adjustment of Beat Frequency Oscillator.

To enable full use to be made of the selectivity of the receiver the B.F.O. must be accurately set to give the optimum beat note of about 1 kc/s in the phones when the receiver is accurately tuned to the signal. A convenient method of finding this setting is to make use of the characteristics of the L.F. Filter, which is adjusted to have maximum response at this frequency. Proceed as follows: After the preliminary warming up period put the Pass-band switch to 100 c/s, the Operational switch to C.W.—MAN and both gain controls at or near maximum so as to have a high level of receiver noise. Adjust to a frequency where no signals are received, or disconnect the aerial. For maximum receiver noise choose the high frequency end of Band 4. Rotate the B.F.O. Control knob to one of the points at which the maximum ringing noise is heard, and leave it in this position. Checks should rarely be necessary if the receiver is left switched on for long periods.

### Use of Pass-Band Switch.

Once the wanted signal has been found the operator should endeavour to use a narrower pass-band so as to get greater protection from interference. A very slight and careful readjustment of tuning may be necessary when switching to the narrower pass-bands.

6,000 c/s Pass-band. Gives best intelligibility of speech, and makes tuning broader, but can only be used when signals are strong and there is little interference. Used for C.W. signals only in exceptional circumstances.

3,000 c/s Pass-band. Better selectivity and less background noise. Recommended for use on speech and when searching.

1,200 c/s Pass-band. High selectivity. Not used on speech. Useful chiefly on Bands 4, 5 and 6.

300 c/s Pass-band. Higher selectivity. Used on C.W. only, chiefly on Bands 1, 2, 3 and 4. Can be used with care on Band 5, but not recommended for use on Band 6.

100 c/s Pass-band. Highest possible selectivity. For use on C.W. only, chiefly on Bands 1 and 2. If used on Bands 3 and 4 greater care in tuning is demanded and the correct setting of B.F.O. becomes increasingly important. Not recommended on Bands 5 and 6.

The narrowest pass-bands can only be employed where the frequency of the transmitted signal is reasonably constant, and the speed of signalling relatively low.

When receiving C.W. on the broad pass-bands and tuning through zero beat it will be found that the signal is equally strong on both sides, but on narrower pass-bands one side will give a stronger note than the other. The weaker signal may even be inaudible. Always tune to the stronger of the two.

Should a signal be tuned-in on a wide pass-band and the wrong side of zero beat be selected, the signal will probably be lost if the operator decides to change to a narrow pass-band. Because of this and the difficulty of distinguishing the stronger signal it is recommended that the 6 kc/s pass-band should not normally be used when tuning-in or searching for a C.W. signal.

### Use of A.V.C.

The use of A.V.C. will be determined chiefly by the conditions prevailing and the skill of the operator. It is given as a general rule, however, that A.V.C. should always be used except where the wanted signal is weak and in danger of being lost because the gain has been reduced by the action of a strong interference on the A.V.C. diode. Examples of this are peaky types of static, and pulse transmissions.

*The H.F. Gain must be controlled manually when transmitting on the same frequency, unless the receiver is being muted by the Side Tone Facility (as in the Type CR. 100/2 receiver) or other effective device.*

On C.W. the A.V.C. is given an increased recovery time-constant. This will tend to broaden the apparent selectivity when searching through strong signals, and thus make tuning slower. To switch off A.V.C. put the Operational Switch to MAN:

### Use of Gain Controls.

The relative positions of H.F. and L.F. gain controls will depend largely on whether the operator is controlling the gain manually to prevent overloading of the H.F. and I.F. amplifiers or relying on the A.V.C. to do it. The rule laid down for general guidance is

On C.W.—A.V.C. } H.F. Gain Control at maximum, except for very strong signals.  
or MOD.—A.V.C. } L.F. Gain Control as desired.  
On C.W.—MAN. } H.F. Gain Control as desired.  
or MOD.—MAN. } L.F. Gain Control at approximately mid position.

### “ Off ” Position of Operational Switch.

Frequency drift of the oscillator due to temperature fluctuation is reduced to a minimum if the receiver is left switched on for long periods.

During short stand-by periods the H.T. to certain stages may be cut off by putting the Operational switch to the OFF position.

### Use of Logging Scale.

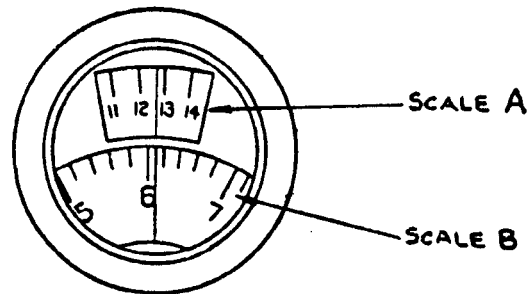

Fig. 2. Logging Scale.

This scale is not for reading frequency directly but for noting how to reset the tuning control to a station which has once been found. Some slight allowance for initial drift should be made if the receiver has not been running for 2 hours or more.

The main divisions 0 to 25 are read on scale “ A ” and sub-divisions on scale “ B.” The example shows a reading of 12—61.

## SECTION 3.

### TECHNICAL DESCRIPTION.

#### (A) ELECTRICAL.

#### **CIRCUIT ARRANGEMENT.** (See Drg. WZ.1943, page 47.)

Two signal frequency stages of amplification employing variable-mu valves are used before the mixer valve, which is of the triode hexode type. The triode section is not used, and the frequency change oscillator is a separate valve. The mixer output voltage at the intermediate frequency of  $465 \text{ kc/s} \pm 2 \text{ kc/s}$  is applied to the I.F. amplifier embodying three stages, with suitable couplings and a crystal gate for varying the band width. The third I.F. amplifier operates a double-diode-triode incorporating the signal detector, the automatic volume control rectifier and the 1st audio frequency amplifier. An independent beat frequency oscillator is provided for continuous wave reception and is coupled to the signal detector.

An output stage and the mains rectifier valve and associated circuits complete the circuit plan.

#### **Aerial Input, Signal Frequency Circuits and Mixer.**

The overall gain of the signal frequency stages does not vary greatly between bands, and is sufficient to make shot noise from the first valve greater than that generated by the mixer valve. Up to a frequency of about 11 Mc/s the dynamic impedance of the first tuned circuit is high enough to ensure that thermal agitation noise from this circuit exceeds valve noise, but on Band 6 the circuit noise has fallen below valve noise, and the sensitivity is then limited by the first valve noise alone.

The feeder or dipole connections are taken via double-pole contacts on the aerial section of the Band-change switch to the low impedance winding of the aerial coupling coil. In the case of the Types CR. 100 and CR. 100/4 receivers the input is suitable for a balanced input if desired, there being two terminals marked "D." For the Types CR. 100/2 and CR. 100/5 receivers, one end of the coupling coil is earthed and the other connected to a coaxial socket marked "D." The coupling is designed to present an impedance of approximately 100 ohms on all bands. The secondary winding with the rear section of the main tuning condenser and the aerial trimmer condenser in parallel form the grid circuit of the first amplifier.

The aerial socket or terminal "A" is connected to the top of this circuit through a capacity of 10 pf, and a static leak of 2 megohms to earth is provided.

The grid connections of signal frequency and 1st Oscillator valves contain stabilizing resistances, the value being 10 ohms for V1, V2 and V3, and 50 ohms for V4.

The rear plate of the rotor of the grid circuit Band-change switch short-circuits the idle inductances while the front plate selects the active one.

The foot of the grid circuit of the two Signal Frequency Amplifiers and the first two Intermediate Frequency Amplifiers is joined to the A.V.C. line through a 50,000 ohms resistance, the top end of which is decoupled by a condenser of  $0.1 \mu\text{F}$  to earth. The decoupling condensers, both for grid and anode circuits of Signal Frequency Stages are situated in the H.F. Coil Assembly.

The cathodes of all signal frequency and intermediate frequency valves have series resistances of 400 ohms or the "preferred value" of 390 ohms  $\pm 20$  per cent., and are decoupled by  $0.1 \mu\text{F}$  condensers to chassis.

The screen grid voltage of signal frequency amplifiers and other valves is taken from a line fed from a voltage divider and is of the order of 80 volts. Each valve has its own screen grid decoupling resistance and condenser.

The coupling from the first to second amplifier is by the conventional untuned anode—tuned grid transformer, the anode being decoupled from the H.T. supply by a resistance of 2,000 ohms and  $0.1 \mu\text{F}$  condenser.

Each grid circuit inductance is fitted with a trimmer condenser. All inductances in the coil pack have adjustable iron dust cores. The second signal frequency stage is similar to the first and drives the 1st grid of the mixer. The mixer cathode resistance is connected to earth and the bottom of grid circuit is also earthed; there is therefore no manual or automatic control of bias on this valve. The triode anode of the X66 is earthed.

### **Oscillator and Intermediate Frequency Circuits.**

A KTW.62 valve connected as a triode and having a tuned grid circuit mutually coupled to an untuned anode coil serves as the frequency change oscillator. The oscillator operates at a frequency higher than the signal frequency on all bands. Series tracker condensers are contained in the coil pack in addition to the usual decoupling condensers. On the three lowest frequency bands variable trimmer condensers are fitted to the oscillator inductances, but on Bands 4, 5 and 6, where very small values of capacity are required, fixed capacitors are connected instead, the required value being determined on test.

The tuned anode circuit of the mixer is decoupled from the H.T. supply and forms the first side circuit of the crystal resonator. The second side circuit is also tuned and is coupled to the 1st intermediate frequency valve. The crystal whose frequency may be between 463 kc/s and 467 kc/s, is neutralised, a fraction of the voltage present in the 2nd side circuit being fed back into the 1st side circuit in the correct phase. The neutralising condenser is situated in I.F.1 assembly and the crystal is mounted in I.F.2 assembly. The crystal is not in circuit when using the 3,000 c/s and 6,000 c/s positions of the Pass-band switch.

The normal band-width with the crystal in circuit is 1,200.c/s. By switching the condenser C.43 (value 7 pF) from the first to the second side-circuit and altering the phase and impedance the band-width is reduced to 300 c/s.

The couplings between the three intermediate frequency amplifiers consist of loosely coupled tuned transformers of high Q, both primary and secondary coils having variable permeability tuning and fixed value capacitors. A small, tightly coupled auxiliary coil is introduced in series with the secondary of the I.F. transformers, I.F.3 and I.F.4, when the Pass-band switch is placed to 6,000 c/s.

The gain of the I.F. amplifiers is of the order of 28 db per stage (25 to 1). The conversion gain of the mixer is about 16 db (6 to 1).

I.F. Sensitivity figures will be found in Section 5, page 30.

The selectivity switches S.10, S.11, S.12 and S.15 in Diagram WZ.1943, page 47, are all operated by a common spindle.

All switches are shown on the diagram in the counter-clockwise position.

### **Signal Detector and A.V.C. Rectifier.**

The signal detector is driven from the secondary of the last I.F. circuit, and works into a series connected load of 0.3 M $\Omega$  with suitable low-pass filtering components, a portion of the rectified voltage being applied to the L.F. gain control potentiometer via a capacity of 0.1  $\mu$ F. The slider of the potentiometer is connected to the grid of the triode section of the DH.63 valve and the bottom is tapped on to a suitable biasing point of the cathode resistance, giving a voltage of 1.8 volts negative with respect to the cathode.

The auto-gain voltage is derived from the second diode of the DH.63 driven from the anode of the 3rd I.F. valve via a capacitor of 100 pF. The A.V.C. diode load of 0.5 M $\Omega$  is in shunt with the valve. In order to have the necessary delay the cathode is biased positive by about 16.8 volts relative to the anode. Suitable decoupling is provided, and an additional capacity of 1  $\mu$ F for increasing the recovery time constant is introduced when the Operational switch is placed to C.W.

The time constant is 0.1 sec. on MOD, and 1.0 sec. on C.W.

### **Beat Frequency Oscillator.**

The B.F.O. is of the electron-coupled Colpitts type, and is coupled to the signal detector through a capacity of 30 pF. The core of the inductance is adjustable as in the I.F. circuits, and a variation of several kilocycles above and below the intermediate frequency is obtained by the variable condenser which is under the control of the operator. The correct adjustment of the B.F.O. condenser is a matter of importance when using narrow pass-bands and is dealt with in Section 2, page 3.

### Audio Frequency Amplifier.

The triode section of the DH.63 is resistance capacity coupled to the grid of the output tetrode, KT.63. A band-pass filter having maximum response at a frequency of about 1 kc/s and a total bandwidth of 100 c/s is inserted here when the Pass-band switch is put to "100 c/s."

The gain of the amplifier at 1 kc/s is not reduced by the insertion of the filter. Suppression of high-frequency voltages is attained by the use of capacitors in shunt with the two audio frequency amplifier valves. Low frequency stability is ensured by adequate decoupling in the H.T. supply to the DH.63 stage.

The various outputs are obtained through a multi-ratio transformer. The slope of the load line, which should be of the order of 5,000 ohms, is determined by the loudspeaker, the line and phone outputs having negligible effect. Other details of outputs are given elsewhere in this Handbook.

### Power Supplies.

The power supply circuits are arranged so that either A.C. mains or D.C. supplies can be used, a change-over being effected by merely plugging in a differently connected supply socket, and changing the position of a D.C./A.C. Heater Link in the receiver. The mains on-off switch is not in circuit when using D.C. supplies. A 2 amps. fuse is used as a link on the primary of the transformer for selecting the appropriate mains voltage tapping.

When using batteries an economy in H.T. current may be effected by reducing to 160 volts, and at this value a further economy can be made by replacing the KT.63 by an L.63 if using receiver for phone reception only. A suitable arrangement of supplies when using batteries and rotary converter is shown on Drg. WZ.1960, page 45.

The rectifying and smoothing circuits are of conventional design.

In later models a 500 mA fuse is fitted in the earth connection of the high voltage winding of the transformer, and a spare fuse housed in the lid of receiver.

### Controls.

The receiver controls, as shown in Fig. 1, page 2, are :—

1. On-Off Mains Switch.
2. Operational Switch (control of A.V.C. and B.F.O.).
3. Pass-band Switch. (Variable Selectivity).
4. H.F. Gain Control Potentiometer.
5. L.F. Gain Control Potentiometer.
6. Band Change Switch.
7. Main Tuning Control (coarse and fine controls).
8. Beat Frequency Oscillator Tuning.
9. Aerial Trimmer Condenser.

### Frequency Band.

The overall frequency band, 60 kc/s to 30 Mc/s, with a gap between 420 kc/s and 500 kc/s, is covered by six positions of the Band-change switch. The bands are

- |                          |                        |
|--------------------------|------------------------|
| 1. 60 kc/s to 160 kc/s.  | 4. 1.4 Mc/s to 4 Mc/s. |
| 2. 160 kc/s to 420 kc/s. | 5. 4 Mc/s to 11 Mc/s.  |
| 3. 500 kc/s to 1.4 Mc/s. | 6. 11 Mc/s to 30 Mc/s. |

### Tuning and Calibration.

The main tuning control has a driving ratio of 25 to 1 and is fitted with a slow motion epicyclic drive having a reduction ratio of about 170 to 1. This control, besides operating the logging scale, moves a pointer across a scale calibrated directly in frequency. The frequency scale is brought into view by the action of the Band-change switch.

### Logging Scale. (See Fig. 2, page 4.)

The logging scale provides a method of retuning to a station already located with rapidity and accuracy. It has a scale length for each frequency band equivalent to 18 feet, and carries 1,250 divisions large enough to allow accurate estimation to the nearest quarter of a division. At the highest frequency of 30 Mc/s this corresponds to only 5,000 c/s in frequency change, so that readjustment to a given reading will bring a desired C.W. station into sufficiently close adjustment to give a beat note within the audio band.

### Selectivity Control.

The width of the intermediate frequency pass-band is controlled by the pass-band switch having 5 positions. At the 100 cycles position a low frequency filter tuned to approximately 1 kc/s is introduced following the 2nd detector.

The pass-bands available are

6,000	cycles total width at half peak amplitude.
3,000	” ” ” ”
1,200	” ” ” ”
300	” ” ” ”
100	” ” ” ”

The gain of the intermediate audio frequency stages does not vary more than a few decibels between any two positions of the pass-band switch.

### H.F. Gain Control.

The gain of the two signal frequency stages and the first two I.F. stages is controlled by varying the positive voltage applied to the cathodes in excess of the normal self-bias developed across the cathode resistance. The range of control is of the order of 100 db.

### L.F. Gain Control.

The amplitude of the signal applied to the grid of the first audio frequency valve is varied by a potentiometer of 0.5 M $\Omega$ , there being a reduction of approximately 50 db when the control is fully counter-clockwise.

### Outputs.

Three levels of output are available.

- (A) Loudspeaker. Approximately 2 watts maximum power.  
CR.100/4 and CR.100/5 to match 1,000 ohms.  
Other models ; to match 3 ohms.

On these latter models the loudspeaker is disconnected when the phone plug is inserted.

- (B) Line. For 600 ohms line or amplifier ; 2 mW, unaffected by connecting phones.
- (C) Phones. Two phone jacks on front panel. Phones of any convenient impedance may be used. Output of the order of 0.3 mW for high impedance phones on standard models, but considerably higher on CR.100/4 and CR.100/5 models.

### Operational Switch.

This is a 5-position switch controlling the use of A.V.C. and the B.F.O. The centre position marked OFF breaks the anode supply to all stages except the L.F. and Output Valves. Its use is to keep heaters alight during short stand-by periods, thus reducing to a minimum any frequency drift caused by temperature variations.

The other points of the switch are

MOD — MAN ; that is, B.F.O. off, A.V.C. off.  
MOD — A.V.C. ; that is, B.F.O. off, A.V.C. on.  
C.W. — A.V.C. ; that is, B.F.O. on, A.V.C. on.  
C.W. — MAN ; that is, B.F.O. on, A.V.C. off.

### Side-tone Facility.

On the Type CR.100/2 receiver facilities are provided for desensitizing the receiver when an associated transmitter is emitting. This consists in raising the cathode line voltage of the receiver when the transmitting key is pressed by introducing all or part of a 2,000 ohms resistance at the earth end of the H.F. gain control potentiometer. The resistance is mounted on the top deck inside the receiver, and should be adjusted so that the operator hears his own transmitted signal at the desired amplitude. The connection to the insulated back contacts of the morse key or relay is made by a length of shielded twin cable, terminated by a plug. When not in use the side-tone socket on the rear of the receiver chassis should be shorted, using the special shorting plug provided.

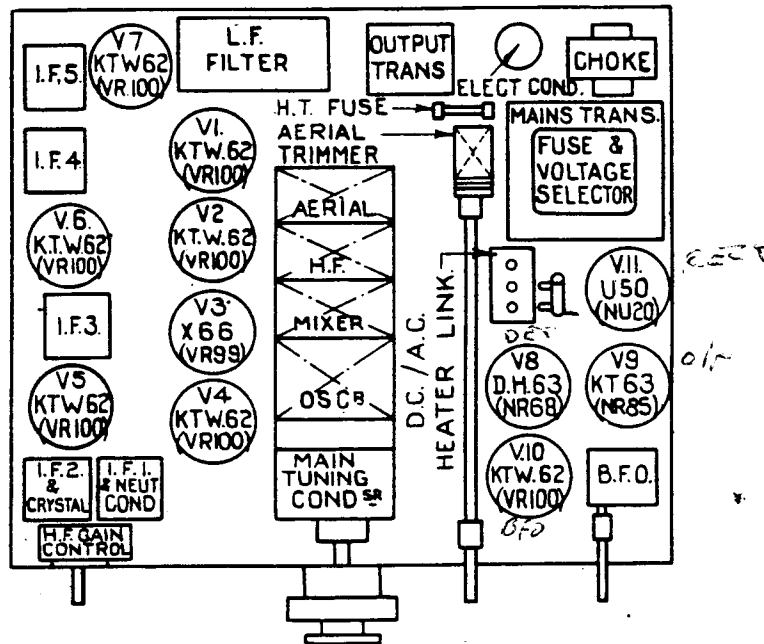

Fig. 3. Plan showing Valve Positions.

**Valve Complement.**

The valve complement of the receiver is here shown with equivalent types and substitutes. The valve number refers to that shown on Circuit Diagram WZ.1943, page 47. The substitutes shown in brackets should be used only in an emergency.

Valve No.	Type	Use	Service Type No.	Possible Substitute.
V1	KTW.62	1st Signal Frequency Amplifier	VR.100	{ KTW.61 = NR.64. (6K7G) (6J7G)
V2	KTW.62	2nd Signal Frequency Amplifier		
V3	X.66	Mixer	VR.99	{ X.65 = NR.82. (6K8G)
V4	KTW.62	Frequency-change Oscillator	VR.100	{ KTW.61 = NR.64. (6J7G) (6K7G)
V5	KTW.62	1st I.F. Amplifier	VR.100	{ KTW.61 = NR.64. (6K7G) (6J7G)
V6	KTW.62	2nd .. ..		
V7	KTW.62	3rd .. ..		
V8	DH.63	{ Combined Signal Detector A.V.C. Diode and L.F. Amplifier	NR.68	(6Q7G)
V9	KT.63	Output Tetrode	{ NR.85 ARP.17	{ (6F6G) (6V6G)
V10	KTW.62	Beat Frequency Oscillator	VR.100	{ KTW.61 = NR.64. (6J7G) (6K7G)
V11	U.50	Full Wave Rectifier	NU.20	{ 5Y3G 5Z4G (U.52)

For plan of Chassis showing position of valves see Fig. 3.



(B) MECHANICAL.

The receiver cabinet is of all metal construction ( $\frac{1}{16}$ -in. motor body steel) and comprises four main members ; chassis, cover with hinged lid, front panel and bottom plate.

The chassis is of the inverted type, with riveted and welded corners. It carries on top the high frequency tuning condenser and calibration sub-assembly, valves, intermediate frequency transformers, crystal circuits, L.F. filter, output transformer and parts of the supply circuit. The H.F. coil pack, condenser and resistance boards and switch controls are carried beneath the chassis.

The front panel is secured to the chassis by Parker Kalon self-tapping screws (which are used whenever possible elsewhere on the receiver). To remove front panel, first remove control knobs and locking ring on supply switch, then take out P.K. screws.

The main cover portion of the cabinet is screwed directly on to the chassis, access to the upper part of the chassis for valve replacements, etc., being then provided through the hinged lid.

The base is screwed flush on to recessed brackets at the bottom of the chassis, and has holes to assist ventilation, and domes on which the receiver rests if bench mounted. The bottom plate may be reversed so that the domes are inwards when the receiver is rack mounted.

The main terminal board and input sockets are mounted at the rear of the chassis, and telephone jacks at the front.

For servicing, the base and cover portion can be removed, leaving the receiver complete with front panel intact.

SECTION 4.

PERFORMANCE.

**Overall Sensitivity.**

The input required to give a signal-to-noise ratio of 20 db (100 to 1 power ratio) on an unmodulated signal, or a ratio of 10 db (10 to 1 power ratio) on a signal modulated 40 per cent. at 400 c/s is shown in Table 1 below, and is measured under the following conditions :—

A non-inductive resistance of 100 ohms is connected between the signal generator and the dipole socket or " D " terminal of the receiver, the other dipole terminal being earthed ; the pass-band switch to 3,000 c/s ; the H.F. gain control at the optimum position ; the A.V.C. not in use. (See page 32.)

TABLE 1.  
OVERALL SENSITIVITY.

<i>Band.</i>	<i>Frequency.</i>	<i>Aerial Input.</i>	
		<i>Average Receiver.</i>	<i>Maximum acceptance figure.</i>
1	60 kc/s	1.5 $\mu$ V	2.0 $\mu$ V
	155 ..	1.2 ..	2.0 ..
2	155 ..	1.4 ..	2.0 ..
	420 ..	1.3 ..	2.0 ..
3	500 ..	1.4 ..	2.0 ..
	1.4 Mc/s	1.3 ..	2.0 ..
4	1.4 ..	1.6 ..	2.0 ..
	4.0 ..	1.2 ..	2.0 ..
5	4.0 ..	1.9 ..	4.0 ..
	11.0 ..	1.4 ..	2.0 ..
6	11.0 ..	3.6 ..	5.0 ..
	28.0 ..	1.7 ..	3.0 ..

**Automatic Volume Control.**

The increase in audio frequency output when the modulated signal input is increased by 60 db (1,000 to 1 in voltage) above the input figures given in third column of Table 1 will not exceed 7 db (2.2 to 1 in voltage).

See Fig. 4, page 49, A.V.C. Response Curves.

**Selectivity of Signal Frequency Circuits. Image Attenuation.**

Table 2 below shows the attenuation offered to the image signal, for frequencies above 1.4 Mc/s. For all frequencies below 1.4 Mc/s the attenuation is greater than 100 db (100,000 to 1 voltage ratio).

TABLE 2.

Band.	Frequency.	Average receiver.		Lowest acceptance figure.	
		db	Voltage ratio.	db	Voltage ratio.
4	1.4 Mc/s	>100 db	>100,000 to 1	100 db	100,000 to 1
	4 "	80 "	10,000 to 1	70 "	3,200 to 1
5	4 "	94 "	50,000 to 1	84 "	16,000 to 1
	11 "	60 "	1,000 to 1	50 "	320 to 1
6	11 "	59 "	890 to 1	50 "	320 to 1
	28 "	30 "	30 to 1	25 "	18 to 1

#### Selectivity of Intermediate Frequency Circuits.

The mid-band frequency of the intermediate frequency pass-band is  $465 \pm 2$  kc/s according to the frequency of the crystal. Table 3 below shows the protection given against adjacent channel signals for the four conditions of pass-band provided.

TABLE 3.

Pass-band Switch Position.	Total Bandwidth for attenuation from peak as under.		
	6 db	40 db	50 db
6,000 c/s	6.0 kc/s	16.0 kc/s	21.0 kc/s
3,000 "	2.7 "	8.5 "	13.0 "
1,200 "	1.2 "	5.4 "	8.8 "
300 "	0.35 "	4.5 "	8.8 "

Table 4 below shows the tolerance permitted in total bandwidth at half peak ordinate, i.e.—6 db.

TABLE 4.

Pass-band Switch.	Maximum permitted Bandwidth.	Minimum permitted Bandwidth.
6,000 c/s.	8,000 c/s.	5,000 c/s.
3,000 "	3,500 "	2,000 "
1,200 "	1,500 "	1,000 "
300 "	450 "	250 "

See Fig. 5, page 49, I.F. Response Curves.

#### Audio Frequency Response.

The audio frequency response is constant to within  $\pm 4\frac{1}{2}$  db of a mean figure for all frequencies between 100 and 6,000 c/s. The insertion of the low frequency filter (i.e. the 100 c/s position of the pass-band switch) ensures that a band of frequencies of approximately 100 c/s in width is passed with less than 6 db attenuation. Frequencies more than 200 c/s from the mid-band frequency are attenuated by at least 20 db.

Figs. 6 and 7 show the Audio Frequency Response and L.F. Filter Response curves.

#### Overall Fidelity Response.

Fig. 8 shows the overall fidelity taken at 1.4 Mc/s with a modulation depth of 40 per cent. for four positions of the pass-band switch.

## SECTION 5.

### MAINTENANCE AND SERVICING.

#### **Packing and Unpacking.**

Do not hold the receiver by its knobs when removing it from its carton.

Turn the main tuning condenser to maximum capacity before transporting the receiver.

See that valves and valve cans are firmly seated, and grid caps connected.

Never lean the receiver on its rear terminals as the aerial sockets are easily damaged.

#### **Cleaning and Lubricating.**

Little attention is required in this respect providing the lid is normally kept closed to exclude dust. The removal of dust is best done by vacuum cleaner, or with a medium-size varnish brush, taking great care not to bend the vanes of the main tuning condenser. The end vanes of each section of this condenser are adjusted by the manufacturer to give correct tracking and should not be interfered with.

Switch mechanism and cord pulley wheels may require a drop of light machine oil on rare occasions, but care should be taken not to splash oil on switch wafers. The rotors of switches are lightly greased when new, and vaseline only should be used for this purpose if ever required, and then used sparingly. Should the surface of switch wafers become coated with dirt and grease they should be cleaned with carbon tetrachloride.

#### **General Care.**

On models which do not have an external pointer and stop, take care not to force the Band-change switch past Band 6, thus over-riding the stop and breaking the band-change cord.

If the receiver is out of its case for repair, stand it either in an upright position, or on its right-hand side, mains transformer downwards. On no account let the weight of the chassis rest on the I.F. Transformer cans.

It is false economy to run with only one dial lamp, as this will then have a reduced life owing to excess voltage.

Occasionally check up on all knobs to see if grub screws are firmly bedded in their pipping holes.

#### **Checking Valve Performance and Changing Valves.**

The H.T. voltage and anode current of valves should be checked at regular intervals, say, every thousand hours the receiver is running. If this is not done the gradual failure of emission in valves is not noticed until serious reduction in performance is reported. A log of these measurements should be kept. The H.T. voltage may be measured by connecting a voltmeter between terminal 3 of the output transformer and the chassis.

When changing valves it may be useful to remember that a tube whose emission has fallen may be unsuitable for the later amplifier stages or as oscillators, but quite good enough for a further period of service in the 1st or 2nd Signal Frequency stages where the grid voltage swing is lower.

Similarly a slightly noisy valve might be suitable in a later stage but not acceptable for an early stage. Certain substitutes indicated in the Valve Complement Table, though useful in an emergency, cannot be expected to give a performance equal to that specified when using the correct type, and greater care must be taken in choosing a substitute valve for the oscillator and B.F.O. stages than elsewhere. An unsuitable type may fail to oscillate, or may generate an oscillatory voltage of an unsuitable amplitude. This is more likely to be so if the receiver is being operated from batteries where the heater voltage is reduced to 6 volts and the H.T. is lower than 250 volts.

Always measure the H.T. first, and fit a new rectifier valve if the H.T. has fallen to a value approaching 200 volts. If this does not restore H.T. to normal, suspect a failing H.T. electrolytic condenser. The regulation of the rectifier is such that the H.T. voltage rises by about 10 per cent. when the H.F. gain control is reduced to minimum.

The anode current of the oscillator valve and the mixer vary slightly according to the frequency and frequency band in use. The figures given refer to measurements made with the receiver at about 12 Mc/s on Band 6.

The use of "preferred values" and wide tolerances in resistance values and valve performances under war-time conditions impose a rather wide tolerance on anode feed figures, and about 20 per cent. variation in the values given may be regarded as reasonable, except in the case of the rectifier voltage.

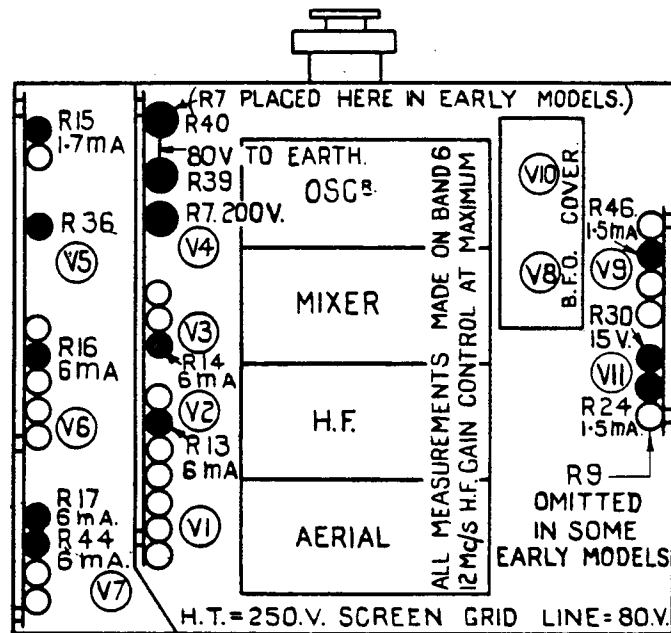

Fig. 9. Plan of Underside showing Test Points.

On early models of the receiver the anode current of the valves V3, V8 and V10 tended to be somewhat lower than the figures given in Table 5, page 15.

A valve feed will fall very low if the screen-grid voltage fails ; e.g., because of a broken-down decoupling condenser.

A valve feed will rise if the cathode bias resistance becomes short-circuited by a faulty by-pass condenser.

The feed of the mixer valve will run high if the 1st oscillator output is feeble or fails.

To measure voltage and current, first remove the bottom plate.

Fig. 9, above, shows the position of the various anode and cathode resistances and the values of current or voltage obtained with maximum H.F. gain. For convenience, these and other readings obtained are tabulated opposite (see Table 5). An Avometer or Avominor, or other simple test meter should be used. In the case of the 1st Oscillator (V4), measure the D.C. voltage drop across the Anode resistance, R7 on diagram. As indicated on Fig 9, the position of this resistance has been changed slightly since the earliest models were introduced. It is easily recognised by its size and colour (red, 3 watt type). On the output valve V9 measure the D.C. voltage drop across the cathode resistance, R30 on diagram. On all other valves the approximate anode feed is obtained by connecting the milliammeter in shunt with the anode decoupling resistance. Care should be taken after clipping the positive lead of the meter to H.T. — not to let the negative lead touch the chassis or a point of low D.C. potential, and for this reason the negative lead should have a "probe" connection. It is preferable to use a meter which is fitted with a fuse or automatic cut-out.

**Voltage and Current Check.** (See Fig. 9, page 14.)

Operational Switch to C.W.—MAN. Receiver tuned to about 12 Mc/s Band 6.

TABLE 5.

<i>Test Point and Circuit Reference</i>		<i>Meter Reading</i>		<i>Remarks</i>
		<i>H.F. Gain at MAX.</i>	<i>H.F. Gain at MIN.</i>	
Top of R7 to chassis	H.T.	250 volts D.C.	280 volts D.C.	Change U50 valve if H.T. has fallen by 15%
*Junction of R39 and R40 to chassis	Screen-grid Line	80 volts D.C.	120 volts D.C.	± 20%
*R36 to chassis	Cathode Line	0	25 volts D.C.	± 20%
*V11 Pin 2 to chassis	Rectifier Output	300 volts D.C.	315 volts D.C.	Tolerance : up to 15% drop.
Across R7	V4, Oscillator Anode Resistance	195 volts D.C.	215 volts D.C.	± 10%
Across R30	V9, Output Valve Cathode	15 volts D.C.	17 volts D.C.	± 20%
Across R13	V1, H.F. Amplifier	6.0 mA	0.3 mA approx.	± 20%
Across R14	V2, H.F. Amplifier	6.0 mA	0.3 mA approx.	± 20%
Across R15	V3, Mixer	1.7 mA	1.8 mA	± 20%
Across R16	V5, I.F. Amplifier	6.0 mA	0.3 mA approx.	± 20%
Across R17	V6, I.F. Amplifier	6.0 mA	0.3 mA approx.	± 20%
Across R44	V7, I.F. Amplifier	6.0 mA	9.0 mA approx.	± 20%
Across R24	V8, D.D. Triode	1.5 mA	1.6 mA approx.	± 20%
Across R46	V10, B.F.O.	1.5 mA	1.6 mA	± 20%

\* The three measurements marked by asterisk may be omitted in routine measurements if desired.

### Hints on Tracing Faults.

Whilst it is not possible to deal with the many and varied faults which may occur in a modern communication receiver, some help can be given in tracing and curing troubles. But it must be pointed out that familiarity with the circuit diagram and the function of each component is the first prerequisite for successful servicing.

The second necessary qualification is to have a logical method of attack. The plan recommended is on the following lines :—

First : Be sure all controls and external connections are correct and that there are no self-evident mistakes, such as Operational Switch to OFF, wrong type of phones or phone plug, low impedance loudspeaker connected to a CR.100/4 or CR.100/5, which models demand a medium impedance, mains plug or socket not fitting snugly, AC/DC heater link in wrong position or broken, mains fuse broken or removed, a valve missing or wrongly placed, side-tone shorting plug disconnected or associated external contacts open. Remove the lids of all valve cans and see that valves are well seated and grid connections firm. Remove bottom plate of receiver and look for scorched or disconnected resistances. Remove B.F.O. cover and inspect for pinched leads. Operate all controls and listen for unusual effects when switching or varying levels.

Second : Attempt to locate the stage at which the fault occurs by simple tests and aural evidence.

Third : If a test meter is available, do not spend too much time on preliminaries, but carry out voltage and current checks (see Fig. 9 and Table 5) and make use of Table 6 (page 17) and the circuit diagram to test circuits for resistance and continuity.

Fourth : If the receiver appears to be working but not efficiently, the state of gang of the high frequency circuits may be checked by the Detune Test (Table 7, page 33), using a calibrated output meter. The H.F. and I.F. Sensitivity also may be measured, using a calibrated Signal Generator and Output Meter (See Table 1, page 11 and page 30).

It should be fairly easy to determine whether a fault is in the early stages, the intermediate frequency stages, or at the audio frequency end, by the amount of receiver noise and its nature, and if affected by touching or shorting circuits or varying the passband switch and other controls. Complete absence of noise indicates broken supplies, or discontinuity or valve failure in audio frequency circuits. A low to medium level of noise, which may or may not vary in pitch as the Passband Switch is varied, will generally point to a fault in the I.F. Circuits or Frequency Changer.

A high level of receiver noise with a distinct change in its pitch and intensity as the Passband Switch is varied but failure to receive signals will generally indicate a fault in Signal Frequency or Oscillator Circuits.

There remain a number of faults not so readily classified, some easily found and others more obscure. Some detailed hints are given under the following headings :—

- (A) Audio frequency circuit faults.
- (B) Intermediate frequency circuit faults.
- (C) Signal and Oscillator frequency and Mixer faults.
- (D) Miscellaneous electrical faults.
- (E) „ „ mechanical faults.

**Resistance Check.**

Receiver to be without valves or dial lamps if full test is being done. Heater link to "D.C."  
 L.F. Gain Control at minimum (fully counter-clockwise).  
 H.F. Gain Control at maximum clockwise. Operational Switch at "C.W.—MAN." Band-pass Switch at "100 c/s."  
 Band-change Switch to 6. Mains Switch to "ON."

Resistance values are subject to  $\pm 20\%$  tolerance. The first figure given is based on the preferred value in ohms. The bracketed figure is based on the original specified value.

TABLE 6.

Test Points	V1	V2	V3	V4	V5	V6	V7	V8	V9	V10
HT+ to Pin 3	2,200 (2,000)	2,200 (2,000)	2,200 (2,000)	22,000 (20,000)	2,200 (2,000)	2,200 (2,000)	2,200 (2,000)	69,000 (70,000)	300	122,000 (120,000)
HT+ to Pin 4	14,700 (15,000)	14,700 (15,000)	39,000 (40,000)	22,000	14,700 (15,000)	14,700 (15,000)	14,700 (15,000)	342,000 (355,000)	<0.1	220,000 (220,000)
HT+ to Pin 5 1M $\Omega$ * on CR.100/4	22,000*	22,000	25,000	22,000	22,000	22,000	22,000	353,000 (333,000)	22,000	22,000
HT+ to Chassis	..	..	..	All valves	..	..	..	22,000	..	..
Chassis to Top Cap	47,000 (50,000)	47,000 (50,000)	10	2,900 (2,600)	47,000 (50,000)	47,000 (50,000)	2.0	10,000	—	110,000
Chassis to Pin 5*	<0.1	<0.1	2,900 (2,600)	44,000 (40,000)	<0.1	<0.1	<0.1	330,000 (310,000)	500	<0.1
	*1M $\Omega$ on CR.100/4									
Chassis to Pin 7	..	..	..	..	<0.1 ohm	..	..	..	..	..
Chassis to Pin 8 H.F. Gain Max.	390 (400)	390 (400)	390 (400)	<0.1	390 (400)	390 (400)	390 (400)	11,200	470 (500)	10,000
Chassis to Pin 8 H.F. Gain Min.	2,390 (2,400)	2,390 (2,400)	390 (400)	<0.1	2,390 (2,400)	2,390 (2,400)	390 (400)	11,200	470 (500)	10,000

Aerial terminal "A" to chassis .. .. . 2.2 megohms.  
 Aerial terminal "D" to chassis on Types CR.100/2 and CR.100/5 : for all frequency bands see Electrical Specification of H.F. Assembly (Table 9, page 35).  
 On Types CR.100 and CR.100/4 this test to be made between the two "D" terminals.  
 Resistance between MAINS PINS, SWITCH to OFF .. .. . Infinity.  
 " " " " " " ON .. .. . 10 ohms.  
 " " " " AND CHASSIS .. .. . Infinity.  
 " " LINE TERMINALS .. .. . 560 ohms.  
 " " " " AND CHASSIS .. .. . (600 ohms.)  
 " " L.S. TERMINALS CR.100 and CR.100/2 .. .. . Infinity.  
 " " " " with phones out .. .. . <0.5 ohm.  
 " " " " CR.100 and CR.100/2 .. .. . <0.5 ohm.  
 " " " " with phones plugged in .. .. . Infinity.  
 " " " " CR.100/4 and CR.100/5 .. .. . 110 ohms.  
 " " " " and CHASSIS .. .. . Infinity.  
 " " PHONE JACK CONTACTS :—  
 470,000 ohms on Types CR.100 and CR.100/2.  
 47,000 ohms on Types CR.100/4 and CR.100/5.



**Standard Colour Code for Resistances.**

The colours are read in the order : Body, Tip, and Dot (or Ring). Body colour indicates first significant figure, Tip colour indicates second significant figure, and Dot or Ring indicates the number of noughts following.

Figure	Colour	Figure	Colour
0	Black	5	Green
1	Brown	6	Blue
2	Red	7	Violet
3	Orange	8	Grey
4	Yellow	9	White

An additional gold or silver spot is used to indicate Tolerances. The tolerance figure has been altered since the system was introduced, but for all resistances encountered it can be said that **GOLD** indicates a tolerance of 5 per cent., whilst **SILVER** may indicate a tolerance of either 10 per cent. or 20 per cent. according to date of manufacture.

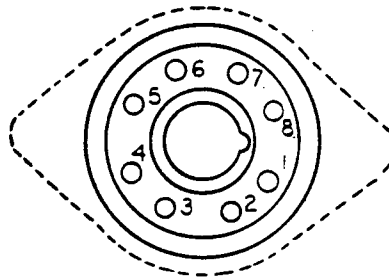

Fig. 10. Underside of Valve Holder.

**Connections to Valve Base.**

Fig. 10 shows the under-side of an octal valve base showing how the pins are numbered. The attached table enables the pin connections of any valve in the receiver to be determined.

The following abbreviations are used :—

- |                         |                        |
|-------------------------|------------------------|
| F = Filament or Heater. | Ao = Oscillator Anode. |
| G = Control Grid.       | Go = „ Grid.           |
| A = Anode.              | C = Cathode.           |
| S = Screen.             | D = Diode Anode.       |
| Sp = Suppressor.        | Tc = Top Cap.          |

Valve Type	1	2	3	4	5	6	7	8	T.C.
X.66	—	F	A	S	Go	Ao	F	C	G
KTW.62	—	F	A	S	Sp	—	F	C	G
DH.63	—	F	A	D2	D1	—	F	C	G
KT.63	—	F	A	S	G	—	F	C	
U.50	—	F	—	A2	—	A1	—	F	

*NOTE.—Certain blank terminals on valve holders are used as anchorage points for wiring and components.*

## DETAILED HINTS ON FAULT LOCATING.

### (a) Audio Frequency Circuit Faults. (See also sub-section (d).)

The continuity of audio frequency circuits from the grid of the DH. 63 onwards can be quickly proved by putting a finger on the top cap and hearing a hum or hoot. If the Pass-band switch is on 100 c/s an audible self oscillation at about 1,000 c/s may be heard when this is done.

Continuity from the cathode of the KT.63 can be proved by hearing a click or scratch of fairly high intensity if an earthed wire is lightly touched on the cathode by-pass condenser C88, 25 $\mu$ F, or resistance R30, 470 (500) ohms. This is not a conclusive test for low amplification which may be caused by a failing or completely useless electrolytic condenser, or by reduced valve emission.

Continuity from the diode load onwards can be checked by touching an earthed wire on to the junction of R10 (200,000 ohms) and R25 (100,000 ohms) situated on the tagboard under the bases of V8 and V10 and hearing a noise, the amplitude of which will vary with the position of the L.F. Gain Control. The B.F.O. cover must be removed for this test.

In the event of a failure of C96 the anode of the KT.63 may become short-circuited. The condenser can be disconnected temporarily until a new one of suitable type (2,000 pF 500 volts) is available.

### (b) Intermediate Frequency Circuit Faults.

It must be emphasized here that when looking for a fault in the I.F. Circuits the adjustment of the tuned circuits should not be interfered with except by trained personnel who have the necessary oscillograph equipment for re-alignment by visual methods. This is especially important in the case of the two circuits associated with the crystal gate, that is, IF1 and IF2 circuits and the neutralizing condenser.

Should a fault be found in the I.F. Amplifier endeavour to put it right with as little disturbance to circuits as possible.

If one coupling transformer has become mistuned it is possible to readjust it for maximum signal output without very great detriment to the overall Intermediate Frequency response curves, but where the crystal circuits or several other circuits are out of alignment any adjustment made to restore sensitivity must be regarded only as an emergency measure until such time as the amplifier can be lined up with special equipment.

Instructions for Circuit Alignment are given later in this Section.

Continuity of amplification can be established as in the audio frequency chain by touching an earthed wire on the cathodes of successive valves and noting the sound in the phones.

Having found which valve fails to respond proceed to further tests using milliammeter and ohmmeter and referring to the diagram of connections.

### (c) Signal and Oscillator Frequency and Mixer Faults.

If all circuits from the grid of V1 onwards are correct touching the grid of either V1, V2 or V3 with a metallic object will produce a noise. With the exception of V1 when on Band 6 shorting any of these grids to the chassis will reduce receiver noise, providing the H.F. gain control is not reduced too severely, and that the Aerial Trimmer has been adjusted for maximum receiver noise.

If the Oscillator V4 fails the receiver noise is reduced and there will be no response to the above tests on V1, V2 and V3. Furthermore the anode current of the Mixer V2 will rise to about 3 mA.

The Oscillator valve may continue to take anode current of approximately the correct value but yet fail to oscillate owing to a circuit fault or the use of an unsuitable valve. Generally speaking a valve which oscillates freely at the lowest frequency of Band 6 should do so at any frequency and this fact will help to decide whether a failure to oscillate is due to the valve or to other causes.

A failure to oscillate may be because of a circuit disconnection or merely a leakage introduced by dirt or grease. Examine the connections on the valve holder, check screen and cathode voltages, anode current, etc., and do continuity checks before deciding on drastic measures. Unsolder connections to fixed and variable condensers and check for short circuits. Look for broken or earthed grid leads. Check switch contacts.

Should it be necessary to repair any section of the H.F. Coil Assembly it may be removed from the chassis without difficulty. Unsolder connections to valve holders, resistances, etc., also the two flexible wires passing through the chassis to the main tuning condenser. Turn Band-change Switch to Band 6 and loosen the two rear grub screws so as to withdraw the Band-change Switch spindle from the operating drum, passing it out through the hole in the rear of the chassis.

The coil assembly concerned can now be taken off the chassis by removing four No. 4 P.K. screws. The surrounding screen can be separated from the base plate by withdrawing four more screws.

If a new section is fitted all connecting wires should be cut to the same length as on the old one.

When re-inserting the spindle ease it through the switch rotors with great care after checking that none of them have been turned 180 degrees out of line. The nick in the keyhole will enable this to be done.

If renewing grid connections note that the oscillator lead should not be screened, and should have a stabilizer of 50 ohms or nearest preferred value.

#### **(d) Miscellaneous Electrical Faults.**

##### *A.V.C. and Signal Diode Faults.*

A rough test for A.V.C. can be done by connecting the receiver to a good aerial and tuning to the carrier wave of a broadcast station. With H.F. gain to maximum (clockwise), Pass-band Switch to 6,000 c/s, Operational Switch to MOD-A.V.C. and L.F. gain raised to a level to suit the loudspeaker or phones the quality of reproduction should be good and background noise low. On changing Operational Switch to MOD-MAN overloading and distortion should be evident.

Change the Operational Switch to C.W.-A.V.C., vary the tuning so as to sweep past a strong carrier wave and note if the receiver noise is quickly reduced and gradually recovers as the carrier is passed.

If A.V.C. fails suspect contacts on the Operational Switch or an earth on the grid decoupling circuit of V1, V2, V5 or V6. Resistance checks should quickly locate the source of the trouble. The most likely components are the A.V.C. decoupling condensers, but sometimes a connecting tag on an I.F. Coil Assembly may be found to be earthing.

With the DH.63 cathode current of 1.5 mA passing through resistances R28 and R29 a positive voltage of 16.8 volts should appear at the cathode, and this serves to "delay" the A.V.C. diode by this amount.

In the event of the electrolytic condenser C87, 25  $\mu$ F, becoming leaky or a short circuit this delay voltage will disappear and A.V.C. will not function properly. The triode section of the valve will also lose its bias, with resulting distortion. Should this condenser become inactive due to old-age but not leaky the audio frequency sensitivity will be reduced without impairing the quality.

##### *Failure of the B.F.O.*

Measure the anode current; try a new valve; remove B.F.O. screening cover (under chassis) and inspect for pinched leads. See that condenser C86, 30 pF, is soldered firmly to pin 5 of valve holder of V8 (DH.63) and not damaged. When checking H.T. current connect the meter direct across R46 so as to include the contacts of the Operational Switch in the test for H.T. continuity. If the failure persists circuit tests must be carried out. See that the Coil Assembly is firmly seated on the chassis and well earthed. Examine variable condenser for short circuit.

##### *Mis-alignment of the B.F.O.*

If the tuned circuit of the B.F.O. is out of alignment it may not be possible to obtain the ringing noise referred to in Section II when adjusting the B.F.O. condenser. If badly out of adjustment, that is several kilocycles or more off the I.F. Circuit frequency, the characteristic noise of the receiver when the Operational Switch is on "C.W." will be high-pitched, and C.W. signals will decrease in strength instead of increasing as the beat note is brought into the region of 1 kc/s when tuning. Two methods of lining-up the B.F.O. by the adjustment of the iron-dust core inductance are given on pages 28 and 30.

The oscillatory voltage developed by the B.F.O. and measured by a high-impedance high-frequency voltmeter at the anode of V10 is of the order of 5 to 7 volts r.m.s.

*Failure or Partial Failure of the Heater and Dial Lamp Circuits.*

See that the Heater Link is firmly plugged in and that the heavy gauge wire in the head is in good contact with the pins. The link should not get hot if operating properly.

*Failure of Loudspeaker Output.*

If the output to the loudspeaker terminals is still interrupted after withdrawing the phone plug check the auxiliary contacts on the phone jack. This does not apply to CR.100/4 and CR.100/5 models.

*Instability and Noise.*

The causes of high frequency or audio frequency instability are many and varied and in most cases can be traced to obvious sources such as defective decoupling condensers, failing electrolytic condensers or breaks in the continuity of screening of leads. Several special cases are mentioned here.

*Instability when Tuned to 420 kc/s Band 2.*

If this occurs at the extreme top of Band 2 and ceases when the H.F. gain control is reduced slightly this may be ignored. If, however, it persists or occurs over a wide band the calibration of the oscillator should be checked. It will probably be found to have drifted in the direction of the Intermediate Frequency of 465 kc/s and an increase of oscillator trimmer capacity may be necessary to correct it.

*Instability when Signal Generator is Connected to Dipole Terminals.*

This may result in a rough noise heard over a broad band of frequencies, and may be due to a disconnection of the earthy end of the dipole winding.

*L.F. Instability on 100 c/s Pass-band.*

This occurs if resistance R9, 20,000 ohms, shunting the primary of the output transformer is disconnected, and is heard as a note of approximately 1,000 c/s.

**(e) Miscellaneous Mechanical Faults.**

*Slow-motion Drives.*

Rough treatment, for example a glancing blow on the tuning spindle which may occur in transport, may cause a "lumpiness" to develop in the slow-motion driving mechanism. In such a case a new drive of improved type, with an improved logging scale, should be fitted.

*Aerial Trimmer Condenser.*

If plates are touching do not bend the moving vanes but grip the fixed vane supports in a vice and bend them very gently.

Should the bearing tighten up, rest the spindle in a "V" block and carefully knock out the pin. Disengage moving vanes.

Remove any abrasions on the surface of the bearing and add a drop of light machine oil before reassembling.

*Broken P.K. Screws.*

Do not attempt to drill out a broken self-tapping screw. Use a light hammer and a punch and knock it out.

*Broken Valve Holder Sockets.*

There is no need to change a valve holder if contacts are broken, as individual contacts are quickly removed by bending back the soldered end of the shoe and pushing it out through the top of the valve holder. Replace by one taken from an idle socket.

*Broken Cords.*

There are two actuating cords associated with the tuning of the receiver, the Band-change cord which rotates the calibrated cylindrical scale, and the Pointer Cord. On early models the Band-change cord operated over a single pulley on to a spring-loaded cylinder. Later models have an endless cord system operating over a 5 wheel pulley. The Pointer Cord mechanism remains unchanged except that on later models there is an inspection hole on the front plate of the scale assembly to facilitate the fitting of a new cord without removing the logging scales and disturbing the main tuning condenser. Instructions for each model are given.

*Fitting New Band-change Cord on Early Models having a Single Pulley.*

Remove the right hand bearing bracket of the calibration cylinder and pull the cylinder out of its left-hand cheek. Take  $3\frac{1}{2}$  feet of new cord, tie a knot in the end and slip a small washer over it. Put the Band-change Switch to 2 so that the eyelet in the operating drum is accessible and pass the cord through it, the washer and knot on the inside of the drum. Pull the cord tight and pass it round the drum about  $\frac{1}{2}$  turn counter-clockwise, up through the hole in the chassis and over the pulley wheel. It should then be passed behind the cheek of the calibration cylinder and round it,  $1\frac{1}{2}$  turns, finally passing it in through the eyelet and tying it to the small spring fully extended. Replace the cylinder and bearing bracket. The main-spring would be at full compression on Band 6. It can be adjusted if necessary by passing a thin "tommy" through the hole in the cylinder spindle, loosening the grub screws, turning the spindle the required amount and tightening the grub screws again.

If the scale opposite the window does not correspond exactly with the position of the Band-change Switch, the operating drum on the Band-change Switch spindle can be moved round slightly after loosening the grub screws.

*Fitting New Band-change Cord on Models having 5-Wheel Pulley.*

(See Fig. 11, page 51.)

Disconnect R.I.S. socket if fitted.

Remove all knobs.

Take out P.K. screws and remove the bottom plate and front panel.

Lift the case off the receiver chassis.

Fit a knob temporarily to Band-change Switch and set this to Band 2 (160 kc/s to 400 kc/s).

Check up that all Oak switches are correctly set to this band. Circuit Diagram WZ, 1943, page 47 shows the connections when all switches are fully counter-clockwise, the numbered contacts being as viewed through the front of the receiver when in an upright position. Band-change Switch is on Band 1 when fully counter-clockwise.

Take off calibrated cylinder by removing the bracket and cheek at right-hand end, and pulling the cylinder out of left-hand cheek.

Receiver is now best laid on its side, *the mains transformer downwards to bench*, actuating spindles to the right-hand of mechanic.

Take 6 feet of cord, bring the ends together and fold the cord double. Pass the loop through the eyelet of Band-change Switch drum from outside to inside, where it should be anchored by a small washer against a figure-of-eight knot.

Stretch the cords until washer is tight against the inside of the operating drum. The drum, if not already secured, should be fixed to the operating rod with its two grub screws, the eyelet being at a point roughly corresponding to 10 o'clock if viewed from the front with the receiver in the normal position.

Take one cord (call this the R.H. Cord) and pass it round the drum one complete turn clockwise (front view) winding from eyelet to the right; that is, successive turns will lie towards the front of the chassis. A piece of stiff wire will be found useful for guiding the cord. The R.H. Cord is now passed up through the hole in chassis to the top deck, and the receiver should now be turned right side up, and the cord held in the right hand with long-nosed pliers whilst it is slipped under the front wheel of the lower pair (wheel A), taking care that the cord does not come off the operating drum. After passing under wheel A the R.H. cord should be taken up and over wheel E, passing from back of wheel towards the front, about  $\frac{2}{3}$  of the periphery being in contact. From wheel E the cord passes down and behind the upper front wheel (wheel C) and thence vertically near the front edge of chassis to wind on to the cheek of the cylinder. Before winding on to the cylinder cheek it is better to secure R.H. cord temporarily to a handy point of the chassis and proceed with the running of the other end of the cord. Call this the L.H. (rear) cord. Again with the receiver on its side take L.H. cord and pass it counter-clockwise round the Band-change Switch operating drum,  $1\frac{1}{2}$  turns, winding from eyelet outwards towards the rear edge of drum, and passing cord up through the hole in the chassis to the top deck. Here the L.H. cord passes up and behind bottom rear wheel (wheel B), and up and in front of rear upper wheel (wheel D) to which it is tangential. This cord should now be secured temporarily. See that the cords are not crossed on the operating drum and are free from kinks.

Now take the R.H. (front) cord and after pulling it tight wind on to cylinder cheek, beginning at the right-hand edge and winding inwards towards the eyelet, approx.  $1\frac{1}{3}$  turns, the cord passing up the front and over the top. Pass end through the eyelet.

Take L.H. (rear) cord up behind the cylinder drum, commencing to wind from left-hand edge, and put on approximately  $1\frac{1}{3}$  turns, and pass through eyelet.

Draw both cords as tight as possible, taking care not to chafe them at any point, and thread them in opposite directions through the hook end of the spring inside cylinder cheek, pulling the spring to full extension and tying cords with a reef knot. Cut off spare ends.

Test Band-change Switch for the operation of cord.

Fit calibrated cylinder into the left-hand cheek and secure with right-hand cheek and bracket. See that there is no end play, fitting a spacer if necessary.

If the correct scale does not come exactly opposite the window a small adjustment can be made by slackening the grub screws and rotating the operating drum slightly on the Band-change Switch spindle.

*Fitting New Pointer Cord on Models having an Inspection Hole in Front Plate of Slow Motion Drive Assembly.*

Remove the knobs and front panel.

Set 0—25 Logging Scale at 22.

Release the pointer from old cord. Pull the cord out through  $1\frac{1}{4}$  in. diam. inspection hole in the front plate of drive, but do not detach it from the spring.

Thread the new cord, which should be 44 ins. long, through the pointer slider and pass the ends round the drum, the right-hand cord clockwise and the left-hand cord counter-clockwise. Tuck the cord through the hole in the periphery of drum. There should be approximately  $1\frac{1}{3}$  turns of cord on the drum.

Pull the spring out through the hole in the plate by means of the old cord. Thread the ends of the cord through the loop of the spring and secure them with a large knot about 1 in. from the end. Cut off the old cord.

Pull the cord back through the hole in the drum, thus extending the spring and ease the cord over the small pulleys at each end of the pulley guide.

Fix the pointer lightly to the cord. Pointer to be at the middle of the scale when the logging scale is at 12.5.

Check the position of the pointer on the calibration scale by tuning the receiver to a station of known frequency near the middle of the scale.

Fix pointer firmly to the cord taking care not to cut it.

Replace the panel and knobs.

*Fitting New Pointer Cord on Models having no Inspection Hole in Front Plate of Slow Motion Drive Assembly.*

Set 0—25 Logging Scale at 22.

Remove the knobs, front panel, and case. Remove the logging scale escutcheon plate.

Unsolder earth connections of 4-Gang tuning condenser, taking care to disturb the wiring as little as possible.

Remove screws securing 4-gang condenser to the chassis. Loosen grub screws securing 0-10 vernier logging scale to the spindle.

Lift and tilt 4-gang condenser assembly sufficient to allow vernier logging scale to be withdrawn from spindle so as to expose the spring for cord.

Release the pointer from the cord and remove the old cord.

Thread the new cord, which should be 44 ins. long, through the pointer slider and pass the ends round the drum, the right-hand cord clock-wise and the left-hand cord counter-clockwise. Tuck the cords through the hole in the periphery of the drum. There should now be approximately  $1\frac{1}{2}$  turns of cord on the drum.

Thread the ends of the cord through the loop of the spring and secure them with a large knot about 1 in. from end.

Pull the cord through the hole in the drum, thus extending the spring, and ease the cord over the small pulleys at each end of the pulley guide.

Replace the logging scale and escutcheon plate, screw down the 4-gang condenser assembly and re-connect.

Fix the pointer to the cord ; pointer to be at the middle of the scale when the logging scale is at 12.5.

Replace the case, panel and knobs.

Check the ganging of the H.F. stages at the first opportunity.

### CIRCUIT ALIGNMENT AND TESTS.

Full instructions for the alignment and checking of performance of all circuits are given here for establishments having the necessary test apparatus and skilled personnel, and some help is given to those who may be called upon to adjust circuits without the use of full laboratory equipment. Attention is again drawn to the risks of spoiling the performance of the crystal gate in the Intermediate Frequency Amplifier if adjustments are attempted without an Oscilloscope and Ganging Oscillator.

#### Use of Output Meter.

Accurate ganging and the measurement of signal-to-noise ratio cannot be done without an output meter. This should be matched to the output valve and connected to the loudspeaker terminals or the appropriate terminals of the output transformer so as to absorb the whole output power of the valve.

The load-line for the KT.63 should be of the order of 5,000 ohms. The output meter should be sensitive enough to give a clear indication of a noise level of 1 mW and be capable of reading accurately up to at least 100 mW, i.e. an increase of 20 decibels.

#### Using A.C. Milliammeter and Resistance.

If an Output Power Meter or similar type of instrument is not available an A.C. milliammeter and a resistance of 1,000 ohms ( $\frac{1}{4}$  watt or larger) may be used. Connect these in series between terminals 5 and 6 of the output transformer, taking care to avoid the H.T. terminals 1, 2 and 3. Then :—

1 mA indicates 1 mW., i.e. zero level.

10 mA indicates 100 mW., i.e. +20 db.

On Naval versions of the receiver the L.S. terminals may be used instead.

#### Using A.C. Avometer (0—1 Amp. scale), as an Indicator.

As an indicator on 3 ohms loudspeaker models the A.C. milliammeter may be connected across the L.S. terminals. Matching will not be correct, but some idea of the level can be gained by taking 0.02A as 1 mW and 0.24A as 100 mW.

#### Adjustment of L.F. Filter.

Apparatus required :—

Tone Generator.

Attenuator 40 db. to match Tone Generator, and terminating resistance for Attenuator.

If an Attenuator is not available use a Potential-divider tapped at  $\frac{1}{100}$  of resistance and matched to Tone Generator.

Blocking Condenser 0.1  $\mu$ F or greater (paper).

Screened connecting lead.

Output Meter.

Resistor, 100,000 ohms with clips.

Connect the attenuator or potential divider across the tone generator. Connect the output of attenuator or potential divider through the blocking condenser by a screened lead to the top cap of DH.63 valve (V8) without disconnecting the grid circuit. Sheath of the connecting lead to be earthed to chassis of receiver and to attenuator and tone generator. Connect output meter to L.S. terminals of receiver. Check zero beat of the Tone Generator and adjust to 950 c/s, at 10 volts.

Set receiver controls thus :—

Both gain controls to maximum.

Bandchange switch to 6.

Pass-band switch to 100 c/s.

Operational switch to MOD-MAN.

Clip 100,000 ohms resistor across variable condenser on first section of the filter-and tune variable condenser on the second section for maximum output.

Disconnect the resistor and clip it across the variable condenser on the second section of the filter, and tune the first section for maximum output.

Repeat this operation twice.

#### Checking the Response of L.F. Filter.

Disconnect 100,000 ohms resistor, and retune tone-generator for maximum response if necessary. Note the reading on output meter.

Raise the frequency of the tone until the output has fallen 6 db (i.e. to half voltage) and note the frequency of the tone. Lower the frequency till the output has again fallen by 6 db below that of the mid frequency and again note the frequency.

The difference between the upper and lower frequencies gives the bandwidth for 6 db drop, and this should not be greater than 150 c/s.

Repeat the above operation for a drop of 20 db (1/10 voltage, or 1/100 power). The bandwidth should not be less than 200 c/s or greater than 400 c/s.

#### Checking the Response of Audio Frequency Amplifier.

Change Pass-band switch to 6,000 c/s.

Vary the frequency of the tone generator between the limits of 100 c/s and 6,000 c/s, noting the output meter reading for each change of frequency.

The response should be within  $\pm 4\frac{1}{2}$  db of the mean value over the whole band.

#### Checking the Gain of Audio Frequency Amplifier.

With receiver controls and connections as before and tone generator set to 1,000 c/s the tone generator voltage should be between 8 and 15 volts to give 50 mW in output meter. The actual voltage at the grid of V8 will be between 0.08 and 0.15 volt.

### ALIGNMENT OF I.F. CIRCUITS AND BEAT FREQUENCY OSCILLATOR.

Three methods are here described, depending on the type of test equipment available, and for convenience named Laboratory Method, Workshop Method and Emergency Method.

Where complete and perfect alignment is required and the necessary apparatus is available the first or Laboratory Method should be used. In most cases however the Workshop Method will be employed and with care should prove quite satisfactory. The Emergency Method will obviously be used only when it is urgently required to regain sensitivity without regard to preserving the very high selectivity of the crystal resonator circuits.

*Notes on Intermediate Frequency Circuit Faults, should be read before re-aligning these circuits.*

### LABORATORY METHOD OF I.F. AND B.F.O. ALIGNMENT (using the special units required)

Apparatus Required :—

Marconi Alignment Oscilloscope, Type TF.852

or { Cossor Ganging Oscillator.

or { Cossor Oscilloscope.

Marconi Special D.C. Amplifier D2A/403.

Calibrated Signal Generator. 465 kc/s variable  $\pm 8$  kc/s.



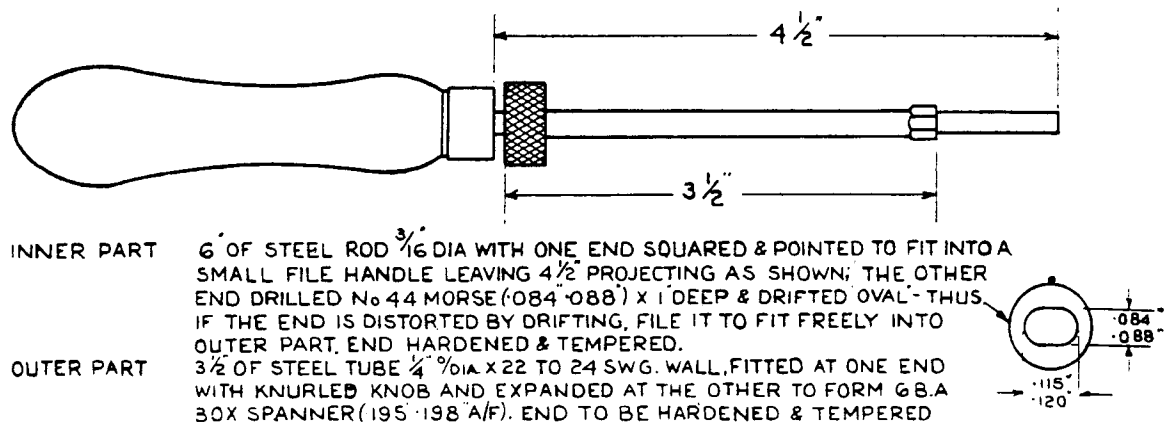

Fig. 12. Ganging Tool.

Ganging Tool, Marconi, TP. 465 sh. 1. (See Fig. 12 above.)  
Headphones.  
Output Power Meter. TF. 340.

**Method of Connection (when using Marconi Alignment Oscilloscope, Type TF. 852)**

Disconnect the Mixer Circuit from the Mixer valve (X.66) in receiver. Connect flexible pair marked "To Mixer" of Alignment Oscilloscope to the top cap of the Mixer valve and to the chassis of the receiver. The Chassis of the receiver should be earthed.

Connect the probe clip of the flexible pair of the Alignment Oscilloscope marked "From 2nd Det." to pin 5 of DH. 63 in the receiver, and the sheath to the chassis. Terminal 5 of DH. 63 valve-holder may be recognised by the 30 pF. condenser connected to it on the underside of the chassis. The screening box under this valve base must first be removed.

**Method of Connection (when using Special D.C. Amplifier and Standard Cossor Units)**

Connect Terminal E of all units to earth.

Connect Terminal X of Ganging Oscillator to Terminal X of Oscilloscope.

Connect the screened input probe lead of the D.C. amplifier to pin 5 of DH. 63 valve in the receiver. Terminal 5 of DH. 63 valve-holder may be recognised by the 30 pF condenser connected to it on the underside of chassis. The screening box under this valve base must first be removed.

Connect output of the D.C. Amplifier to Terminal Y on the Oscilloscope.

Put Oscilloscope switch to "D.C."

Connect output of the Ganging Oscillator to the top cap of the Mixer valve (X.66), first disconnecting the Mixer Circuit from the valve.

**Preliminary Adjustment of I.F. Circuits (when all circuits are greatly out of adjustment).**

Set the Receiver controls thus :-

- H.F. gain control at or near maximum clockwise.
- Band-change switch to 6.
- Operational switch to MOD-MAN.
- Pass-band switch to 3,000 c/s.

Apply an unmodulated signal of frequency 465 kc/s to the Mixer valve. If using the Marconi Alignment Oscilloscope, this is obtained by putting the bandwidth switch to OFF, thus cutting off the frequency modulation. If using a Cossor Ganging Oscillator the operator may prefer to apply an amplitude modulated signal in order to listen with headphones.

Loosen lock-nuts of all I.F. inductances and reduce the inductance to minimum by screwing the iron dust cores out as far as possible. There are five I.F. units. On I.F.1 and I.F.2 there is one inductance, adjustable from the top. On other I.F. units both primary and secondary are adjustable, one from the top and the other from the bottom of the can. The receiver is best laid on its right side with the bottom plate removed, and the under-side of the receiver towards the operator.

Using the oscilloscope as an indicator of maximum output, tune all I.F. circuits, reducing the H.F. gain as necessary to prevent over-loading when the output is sufficient to give a good deflection on the screen. If two tune points are observed when adjusting the inductance, choose the one with the core furthest out of coil.

*The preliminary adjustment may be omitted if found to be unnecessary.*

#### Lining-up I.F. Circuits to the Crystal Resonator.

Put the pass-band switch on the receiver to 1,200 c/s, thus introducing the crystal.

Apply frequency modulation to the Mixer valve. If using the alignment oscilloscope, put the bandwidth switch to XI or X2 ; the wide sweep will probably be preferred. If using a Cossor Ganging Oscillator use a sweep of about 25 kc/s and commence work with full oscillator level.

Adjust the Oscilloscope brilliancy and focus and set the Time Base to have a low velocity, about 10 per second.

In order to compress the hump of the resonance curve and give greater prominence to small peaks and clefts near zero datum, the internal feed-back of the D.C. Amplifier should be switched on. If using the alignment oscilloscope this is done by putting the limiter switch to "LOG".

A resonance curve resembling that in Fig. 13(a), page 49, should now be seen on the C.R.O. screen. The frequency at peak amplitude will be the frequency to which the ganging oscillator was set for the preliminary adjustment, but it is most unlikely that this will correspond exactly with the resonant frequency of the crystal, which may be within a tolerance of  $\pm 2$  kc/s on 465 kc/s.

The crystal resonance will appear on the screen as a sharp peak which may be of very small amplitude and be separated from the main resonance curve or be situated on one of its skirts. It may be necessary to raise the signal level and gain of the receiver to maximum (thus causing distortion of main curve) before it is clearly recognised. Once established, all circuits should be retuned so as to increase its amplitude and the preliminary response curve will die away as the crystal response curve grows. The mean frequency of the ganging oscillator should be adjusted to move the crystal curve to the middle of the screen. *The H.F. gain and amplitude of the ganging oscillator signal should be progressively reduced to prevent overloading and flattening of the peak of the curve.*

The curve seen will resemble one of those shown in Figs. 13(b), (c), (d), and (f).

Observe that by varying the setting of the crystal neutralising condenser a lump seen on one skirt of the curve can be made to diminish to zero or appear on the opposite skirt. Adjust the condenser using a fine screw-driver, till this unwanted component disappears, leaving well balanced skirts. The neutralising condenser is adjusted from the under-side of the I.F.1 can.

Having obtained a clear curve, readjust I.F.1 and I.F.2 for maximum width rather than amplitude and re-align the other circuits if necessary. The curve seen should appear as in Fig. 13(f).

Observe the response curve on the tube at other positions of the Pass-band switch. On switching to 300 cycles a small reduction of peak amplitude may occur and a slight fuzziness will be seen on one side of the curve. (See Fig. 13(e).) This is a normal effect when frequency modulation is applied to a narrow-pass crystal circuit. If it is seen in the 1,200 cycles position it is a sign that the 1,200 c/s curve is not broad enough or curve is too steep on one side. *Do not make any adjustments with the Pass-band switch in the 300 c/s position.* The curve on 6,000 c/s should be well balanced and flattish at top and not necessarily of equal peak amplitude to the 3,000 c/s curve. The shaping of the 6,000 c/s curve will depend largely on the adjustment of I.F.5. See Figs. 13(g) and 13(h).

It is important that the mean frequency ordinate, that is the peak of curve, does not shift to right or left on the screen when the Pass-band switch is changed.

Frequent checks for overloading and consequent flattening of tops of narrow pass curves must be made, and the H.F. gain kept as low as practicable to prevent this.

Lock the Neutralising Condenser and all iron-dust cores, observing that the curve does not change either in amplitude or width.

### Lining-up the Beat Frequency Oscillator (B.F.O.)

Before measuring the bandwidth of I.F. Circuits the inductance of the Beat Frequency Oscillator should be adjusted so that its frequency can be varied by an equal amount above and below the frequency of the crystal when the B.F.O. control knob is manipulated.

The C.R.O. Ganging Equipment is connected as before.

Apply an unmodulated signal to the Mixer valve.

Pass-band switch on receiver to 300 c/s.

Operational switch on receiver to MOD-MAN.

Set the B.F.O. knob on the receiver in mid-position. This is determined by the pin through the spindle nearest the B.F.O. unit being horizontal : that is, parallel to the surface of the chassis.

Tune the Ganging Oscillator for greatest deflection on the Oscilloscope screen.

Change the Operational Switch on the Receiver to CW-MAN, thus switching on the B.F.O.

Vary the iron-dust core adjustment of the B.F.O. Inductance till zero beat is heard in the phones and observed on the screen. Lock the core. It should now be possible to vary the note to an equal pitch on either side of the zero by manipulating the B.F.O. control knob.

### I.F. Bandwidth Check.

After lining up the I.F. and B.F.O. circuits, the width of the Intermediate Frequency pass-band should be measured. Where Marconi Alignment Oscilloscope is used, the bandwidth of the observed response curve at half peak amplitude is read directly on the calibrated oscillograph screen.

Where the available oscilloscope has not been calibrated in conjunction with its associated frequency-modulated oscillator, the oscilloscope and amplifier will be used merely as an indicator of signal amplitude at the 2nd Detector, and instead of a frequency modulated signal a pure C.W. signal should be applied at the Mixer valve. This signal should be provided by a calibrated signal generator whose frequency can be varied by a known amount above and below the frequency of the I.F. crystal resonator. It should first be carefully tuned to the crystal frequency with the pass-band switch in the 300 c/s position. The total bandwidth of the response curves is measured in cycles/sec. at the two points where the amplitude has fallen by 6 db, that is, to half the peak value. The tolerance permitted is shown below :—

<i>Pass-band switch</i>	<i>Maximum permissible Bandwidth.</i>	<i>Minimum permissible Bandwidth.</i>
6,000 c/s	8,000 c/s	5,000 c/s
3,000 „	3,500 „	2,000 „
1,200 „	1,500 „	1,000 „
300 „	450 „	250 „
100 „		

It should be noted that the internal feed-back in the D.C. Amplifier should be switched off, (that is, the Limiter switch placed to LINEAR), otherwise a 6 db drop in voltage will not cause a decrease in the deflection of the spot by a half, but by an amount less than half, depending on the characteristics of the amplifier.

### WORKSHOP METHOD OF I.F. AND B.F.O. ALIGNMENT (for use when special apparatus is not available).

#### Apparatus Required :—

Cossor Ganging Oscillator (frequency/amplitude modulation).

Cossor Oscilloscope and Time Base.

Calibrated Signal Generator, 465 kc/s variable  $\pm$  8 kc/s.

Ganging Tool, Marconi TP. 465 Sh. 1.

Headphones.

Output Power Meter, TF. 340.

### Method of Connection.

Connect Terminal E of all units to earth.  
Connect Terminal A2 of Oscilloscope to earth.  
Connect Terminal A1 of Oscilloscope to pin 5 of 2nd Detector DH.63 of Receiver ; short lead, screened if necessary.  
Connect Terminal X of Ganging Oscillator to terminal X of Oscilloscope.  
Put Selector switch on Oscilloscope to " Y1 Y2 ".  
Connect Output of Ganging Oscillator to top cap of X.66 Mixer valve in Receiver. Mixer circuit disconnected.

### Lining-up I.F. Circuits.

Proceed to line up as detailed in the Laboratory Method, but the figure seen on the Oscilloscope screen will be different in several respects, and certain precautions must be taken to avoid errors of adjustment. It must be remembered that the Oscilloscope Amplifier, when connected to the 2nd Detector, will throw in some additional capacity across the I.F.5 transformer, and this circuit must therefore be retuned later. Also the amplifier cannot faithfully reproduce steep-sided D.C. pulses and the spot will be seen to sweep below the zero voltage datum at the skirts of the curve. Another difference observed will be the presence of the intermediate frequency within the envelope.

These differences are shown in the accompanying oscillograms, Figs. 14(a) and 14(b), page 49.

As before the H.F. gain of receiver may have to be raised to maximum in order to locate the crystal resonance, but it should be reduced progressively afterwards in order to prevent overloading and consequent distortion of the figure. The time base frequency should not be greater than 10 per second.

### Re-tuning I.F.5 Transformer.

After all circuits have been adjusted to give the best shaped curves corresponding in width at about  $\frac{2}{3}$  amplitude from bottom of sweep to values shown on the Pass-band switch, the Oscilloscope Amplifier terminal A1 should be disconnected from the 2nd Detector of the Receiver and connected instead to the junction of R.10 (200,000 ohms) and R.25 (100,000 ohms) which will be easily located on the tagboard near the base of V8 valve.

The response curve now seen on the screen will be a line and not a half " modulated envelope " as before. See Figs. 14(c) and 14(d). Retune the I.F.5 primary and secondary for maximum peak, afterwards readjusting with the pass-band switch on the receiver set to 6,000 for best symmetry about the same mean ordinate as on other pass-band switch positions.

*If the circuits are thought to be in reasonably good adjustment when commencing work the whole of the alignment may be made with the Cossor Oscilloscope connected to the junction of R.10 and R.25, instead of commencing at pin 5 of the 2nd Detector valve.*

Adjust the B.F.O. and check the bandwidth as before.

### EMERGENCY METHOD OF I.F. ALIGNMENT (not covering crystal filter adjustments).

#### Apparatus Required :—

Output Power Meter, TF. 340.  
Signal Generator, 465 kc/s variable  $\pm 8$  kc/s.  
Phones.  
Ganging Tool. Marconi TP. 465, Sh.1.

This method should be employed only where an Oscilloscope and Ganging Oscillator are not available, and repairs or adjustments are urgently required.

First make stage-by-stage measurements of I.F. Sensitivity, as described on page 30, in order to determine in which circuits there is a loss of sensitivity. Then bring these circuits into alignment with the others by adjusting them for peak output at the loudspeaker terminals, the signal being injected at the Mixer grid. The pass-band switch should be set to 1,200 c/s.

*If it is found that the crystal circuits are out of adjustment it is most unlikely that they can be correctly re-aligned except by one of the two previously described visual methods.*

In these circumstances all or any of the I.F. circuits should be adjusted for maximum output with the Pass-band switch in the 3,000 c/s position. There should be no difficulty in raising the sensitivity to agree with the figures on page 30, but it must be realised that the crystal will probably be inoperative and there will be no reduction of bandwidth when the pass-band switch is changed from 3,000 c/s to 1,200 c/s and 300 c/s.

### Simple Method for Lining-up B.F.O. without Test Apparatus.

The Beat Frequency Oscillator can be adjusted without the aid of laboratory equipment using the following simple method.

Put Pass-band switch on receiver to 1,200 c/s. and Operational switch on MOD-A.V.C.

Connect an aerial to receiver and tune in a strong carrier signal, preferably on Bands 1, 2 or 3. The exact tune point will be indicated by the maximum muting of receiver by the action of A.V.C.; that is, tune carefully for minimum receiver noise.

Put the Operational switch to C.W.-A.V.C.

Set the B.F.O. control to mid-position; that is, the pin in the spindle nearest the can to be horizontal.

Adjust the B.F.O. inductance core for zero beat, and lock up.

Check that the note can be raised to an equal pitch on either side of zero when manipulating the control knob.

### Measurement of I.F. Sensitivity. Maximum Gain.

#### Apparatus Required :—

Calibrated Signal Generator 465  $\pm$ 2 kc/s.

Calibrated Output Power Meter.

#### Connect apparatus thus :—

Disconnect Mixer Circuit of Receiver from X.66 valve grid and connect Signal Generator.

Connect output Meter to loudspeaker terminals of Receiver, to match 3 ohms, in the case of a Receiver Type CR.100 and CR.100/2, or 1,000 ohms for Type CR.100/4 and CR.100/5.

Set Receiver controls thus :—

Pass-band switch to 300 c/s. Operational switch to C.W.-MAN.

Put both gain controls to MAX.

Switch on the Signal Generator and carefully tune for maximum receiver response. Put the Pass-band switch to 3,000 c/s. Adjust the signal level to have 100 mW in the output meter. Note this signal voltage. Transfer the Signal Generator connection successively to the grids of V5, V6 and V7, leaving the controls as before and raising the signal level to have 100mW. Do not disconnect the grid circuits, except the Mixer stage.

The voltages required should be of the following order :

V3 Mixer .. 10 $\mu$ V      V5 .. 50 $\mu$ V      V6 .. 1,000 $\mu$ V      V7 .. 30,000 $\mu$ V

A tolerance of several decibels each way is permitted.

### Measurement of I.F. Sensitivity, Signal-to-Noise Ratio.

The overall sensitivity of the I.F. and audio-frequency stages on the basis of a Signal-to-Noise Ratio of 20 decibels may be measured, using the same equipment and method of connection.

Set the H.F. Gain Control to maximum, but reduce the L.F. Gain so as to have 1 mW of receiver noise (i.e. zero level) in the output meter, the signal generator being connected to the top cap of the Mixer valve and the Mixer grid circuit disconnected. Switch on the signal generator, tune it carefully for peak output at the frequency of the I.F. circuits, and raise the signal level to have 100 mW output. The Pass-band switch should be at 3,000 c/s and the signal unmodulated. The voltage required will be of the order of 23  $\mu$ V, but should not exceed 26 $\mu$ V as an outside figure.

Checks for limitation should be made : and if apparent the measurement should be repeated with the H.F. Gain slightly reduced and the L.F. Gain readjusted for zero level.

Limitation is recognised by the failure of the amplifier to give an increased output for an increase of input, and is corrected by increasing the grid bias or reducing the signal level.

### Checking the Relative Sensitivity for Different Bandwidths.

Injecting an unmodulated signal at the grid of the Mixer, the output at the loudspeaker terminals may vary by 2 db between any two positions of the Pass-band switch, with the exception of 6,000 cycles which may be permitted a tolerance of 6 db relative to the 3,000 cycles position.

*NOTE.* The B.F.O. must be accurately adjusted to the L.F. filter before using the 100 cycles pass-band, as described in Section 2.

The Signal Generator must be carefully tuned for peak output in the 300 c/s position of the pass-band switch.

## ALIGNMENT OF SIGNAL AND OSCILLATOR CIRCUITS.

**Apparatus required** :—Calibrated Signal Generator, 60 kc/s to 30 Mc/s  
 Output Power Meter.  
 Headphones.  
 Ganging Tool, Marconi Type TP. 465, Sh. 1.

### Adjustment of 1st Oscillator.

The 1st Oscillator circuits are to be adjusted on all bands to oscillate at a frequency greater than the signal frequency by an amount equal to the Intermediate Frequency, this frequency being determined by the crystal.

The recommended method is as follows :—

Set both gain controls to maximum, the Pass-band Switch to 100 c/s, and the Operational Switch to C.W.-MAN; adjust the B.F.O. for maximum ringing noise. Connect the signal generator to the grid of V3 (X66 Mixer) leaving the grid circuit connected. Connect the output meter to L.S. terminals. The Oscillator section is nearest the front of the receiver.

Commence by the adjustment of Band 1. Adjust the signal generator and the receiver to 60 kc/s and inject a signal voltage of about 50  $\mu$ V. Slacken back the adjusting screw of the trimmer condenser about half a turn from maximum capacity. Using the ganging tool, loosen the lock nut on the top of Band 1 inductance and adjust the iron-dust core (called the "slug") for maximum output.

Set the signal generator and the receiver to 160 kc/s and adjust the trimmer condenser for maximum output, reducing the H.F. Gain as necessary to prevent overloading of 3rd I.F. amplifier. A safe and convenient level of output for ganging adjustments is of the order of 50 mW.

After adjusting the trimmer repeat the adjustment of the slug at 60 kc/s and tighten the lock nut. Finally re-adjust the trimmer at 160 kc/s.

Proceed to set the oscillator on all other frequency bands, adjusting the inductance at the low frequency end of the scale and the capacity at the top. On higher frequency bands it will be found necessary to use a broader pass-band on the I.F. Amplifier and on Band 6 the Pass-band switch should be on 3,000 c/s. It is not advisable to use the 6,000 c/s position.

On bands 4, 5 and 6 where no variable trimmer is fitted the required value is determined on test and a small fixed condenser connected. The average values are :

Band 4 .. 7 pF.                      Band 5 .. 2 pF.                      Band 6 .. 4 pF.

The marked frequencies at the bottom and top of each band are :—

Band 1.	60 kc/s	—	160 kc/s.	Band 4.	1.4 Mc/s	—	4 Mc/s.
" 2.	160 "	—	400 "	" 5.	4 "	—	11 "
" 3.	500 "	—	1.4 Mc/s.	" 6.	11 "	—	30 "

Care must be taken at the top of Band 6 to set the oscillator to work at 30.465 Mc/s and not at 29.535 Mc/s when the scale pointer is at 30 Mc/s as this would result in tracking errors.

If the correct adjustments have been made a signal of 30 Mc/s injected at the Mixer should be heard with the receiver adjusted to 30 Mc/s and also if tuned to 29.07 Mc/s.

### Lining-up Signal Frequency Circuits.

Commencing on Band 1 all signal frequency circuits should now be adjusted for maximum sensitivity. Inject the signal at the required frequency between the dipole and earth terminals (remembering to earth the second "D" terminal if on Types CR.100 or CR.100/4). When commencing it may be necessary to have a signal voltage of the order of 20  $\mu$ V and H.F. Gain at maximum, but as circuits are brought into gang the input should be progressively reduced, finally working with an input of the order of several micro volts and H.F. Gain less than maximum.

As in the case of the oscillator section, inductance slugs should be adjusted and locked at the low-frequency end, and the trimmer condensers at the high-frequency end of each band. The aerial trimmer should be set to  $\frac{1}{2}$  capacity whilst ganging this circuit. On the lower signal frequency bands use narrow I.F. pass-bands, changing to broader pass-bands as difficulty is experienced in holding the signal. It is helpful to listen with headphones whilst watching the output meter. On Types CR. 100 and CR. 100/2 the phones should be connected either across the Line terminals or partly inserted at the jack so as not to break the L.S. connection.

On Bands 4, 5 and 6 adjustments to H.F. and Mixer Circuits may tend to pull the Oscillator frequency, and the note will be heard to change as the circuits are adjusted. It is necessary therefore to follow the signal very carefully with the slow motion tuning control and note the output meter level as each change is made. Because of pulling it is found easier to gang-up on receiver noise rather than on the signal when adjusting trimmers at the top of Bands 5 and 6. The final check should however be done on signal and a measurement of sensitivity (Signal/Noise ratio) and Image Attenuation at 28 Mc/s will show up any errors. The input voltage at the Image Frequency of 28.93 Mc/s should be at least 18 times that of the Signal Frequency to give the same output, the Receiver being set to 28 Mc/s.

#### Sensitivity and Image Protection Check.

After all circuits have been adjusted Sensitivity and Image Protection ratios should be measured ; see Section IV, Performance.

If the figures obtained are unsatisfactory the alignment must be improved. The Image-to-Signal ratio at or near the top of Band 6 will serve as a very sensitive indication of the state of gang, this being the most difficult frequency band to adjust. The frequency of the Image is higher than the Signal frequency by twice the Intermediate Frequency, i.e. by 0.93 Mc/s.

When measuring sensitivity the signal generator should be connected to the dipole input through a non-inductive resistance of 100 ohms, the aerial trimmer adjusted for maximum response, and H.F. and L.F. gain controls adjusted to have an output of 1 mW of receiver noise in the absence of the signal. The signal should then be applied and accurately tuned in and its level raised so as to have the required output. For a C.W. signal and with Operational Switch to "C.W.-MAN" this should be 100 mW (i.e. 20 db Signal/Noise ratio). For a signal modulated 40 per cent. at 400 c/s and with Operational Switch to "MOD-MAN" this should be 10 mW (i.e. 10 db Signal/Noise ratio). The Pass-band Switch should be at 3,000 c/s in either case and the H.F. Gain Control at the optimum setting. On some frequencies the optimum setting will be fully clockwise, but at the top of most bands it will be necessary to reduce the H.F. gain somewhat to avoid saturation of the 3rd I.F. Amplifier. Checks for limitation must therefore be made and the H.F. gain reduced as much as this limitation demands, and the L.F. gain readjusted to keep the noise at zero level (1 mW).

When measuring sensitivity at 1.4 Mc/s do not be misled by the 3rd Harmonic of the B.F.O. which may be at or near this frequency. If necessary make a slight change of frequency for the test.

#### Detune Ratio Test.

The state of gang of the three signal-frequency circuits can be quickly tested without the use of a calibrated signal generator. It will be necessary however to have an output meter calibrated in decibels.

Set controls thus :—

Pass-band Switch to 3,000 c/s.

Operational Switch to C.W.-MAN.

H.F. Gain to maximum.

L.F. Gain adjusted to have a convenient level of receiver noise on output meter but not exceeding 100 mW (i.e. +20 db rel. 1 mW).

Aerial terminals should not be connected externally and there should be freedom from mains-borne noise or random pick-up of signals and static. Adjust aerial trimmer for maximum receiver noise for each frequency change. Now short-circuit in turn the Aerial, H.F. and Mixer sections of the 4 gang tuning condenser using a small screwdriver between chassis and fixed vanes, and note by how many decibels the receiver noise is reduced. The goodness of the circuit will be in direct proportion to the drop in circuit noise. The circuit not in gang will have a reduced Detune Ratio and circuits following will be correspondingly reduced.

Example :—

All Circuits in gang  
 .. .. except Aerial in gang

<i>Aerial.</i>	<i>H.F.</i>	<i>Mixer.</i>
7½ db.	24 db	29 db
1½ ..	19 ..	24 ..

It will be seen that the increase of Detune Ratio between one stage and the next is preserved when the aerial circuit is out of adjustment but the Detune Ratio of the aerial circuit has almost disappeared. The Detune Ratio will be reduced if the H.F. Gain is reduced.

The figures given below in Table 7 are subject to fairly wide tolerances ; of the order of :  
 1 db in 3.      2 db in 6.      4 db in 12.      6 db in 18.

Their principal use may be in comparing sensitivity from time to time where results are carefully logged.

**Detune Ratios in decibels.**

TABLE 7.

<i>Band.</i>	<i>Freq.</i>	<i>Aerial</i>	<i>H.F.</i>	<i>Mixer.</i>
1	60 kc/s	9	13	15
	160 "	16	26	29
2	160 "	8	14	17
	400 "	12	25	29
3	.5 Mc/s	7	12	14
	1.4 "	11	19	22
4	1.4 "	6	16	18
	4 "	8	25	29
5	4 "	4	13	15
	11 "	6	18	21
6	11 "	0	7	9
	28 "	1	12	15

**Maximum Noise Levels.**

The amount of circuit and valve noise generated in the receiver will give some rough indication of overall sensitivity, and the figures obtained on an average receiver and given below may be useful for record purposes, especially if read in conjunction with those in Table 7.

On frequencies near the top of certain bands the noise may be sufficient to cause overloading of the Audio frequency amplifier and the L.F. Gain must therefore be lowered by a fixed ratio, say 10 db, before commencing the test and should be done with the H.F. Gain at maximum and receiver on a frequency at which the noise is not unusually high, say the bottom of Band 5 or Band 6.

The figures given in Table 8 are subject to wide tolerances and are for general guidance only.

**Noise Level of Average Receiver.**

H.F. Gain at Maximum.

L.F. " reduced by 10 db.

TABLE 8.

<i>Band.</i>	<i>Freq.</i>	<i>Noise level, Relative 1 mW zero level.</i>
1	60 kc/s	+3 db
	160 "	+18 "
2	160 "	+2 "
	400 "	+7 "
3	.5 Mc/s	0
	1.4 "	+18 "
4	1.4 "	-7 "
	4 "	-25 "
5	4 "	+4 "
	11 "	+18 "
6	11 "	-1 "
	28 "	+8 "

*Note.* The Aerial Trimmer should be adjusted for maximum noise at each frequency. There should be freedom from site noise and random pick-up. The receiver should be effectively earthed.



## ELECTRICAL DATA OF COMPONENTS.

### L.F. Filter Sub-Assembly.

The electrical specification of the L.F. filter is as follows :—

D.C. Resistance across first section	500 ohms $\pm 15$ per cent.
"    "    "    earth and tap	60 " $\pm 15$ " "
"    "    "    second section	550 " $\pm 15$ " "
Inductance of each section measured at 1,000 c/s (no D.C.)	5 H. $\pm 3$ per cent.
Q measured at 1,000 c/s (no D.C.) not less than	20
Bandwidth of unit at 6 db below max.	100—150 c/s
"    "    "    "    20 "    "    "	200—400 "

### Output Transformer.

The D.C. Resistance of the output transformer is as follows :—

Ohmmeter Connected.	Resistance.
Between tags 1—3	300 ohms $\pm 15\%$
"    "    1 and 2	110 " $\pm 15\%$
"    "    4—6	300 " $\pm 15\%$
"    "    5 and 6	110 " $\pm 15\%$
"    "    7—8	0.35 " $\pm 15\%$
"    "    9—10	0.35 " $\pm 15\%$

The insulation resistance between windings, and windings and core is more than 50 Megohms tested at 500 volts.

The audio frequency response is to be within  $\pm 4\frac{1}{2}$  db of a mean value for all frequencies between 100 and 6,000 cycles per second when tested under working conditions.

### Mains Transformer.

The D.C. resistance of the mains transformer is as follows :—

Ohmmeter connected to	Tap.	Resistance.
Primary winding	200/215	10 ohms $\pm 15\%$
"    "	220/230	11 " $\pm 15\%$
"    "	240/250	12 " $\pm 15\%$
H.T. each half } L.T. " }		65 " $\pm 15\%$
"    "		0.1 " $\pm 15\%$
"    "		0.1 " $\pm 15\%$

The insulation resistance between windings, and windings and core is more than 50 Megohms tested at 500 volts.

The voltage and currents are as follows :—

Primary volts	230 volts A.C.
"    current (no load)	0.1 ampere $\pm 25\%$
Secondary H.T. winding	300—0—300 volts $\pm 5\%$ at 100 milliamps (rectified D.C.)
L.T. winding	6.3 volts $\pm 5\%$ at 4 amps A.C.
Rectifier filament winding	5.0 volts $\pm 5\%$ at 2 amps A.C.

### Smoothing Chokes.

The D.C. resistance of the smoothing choke is 225 ohms  $\pm 15\%$ .

The insulation resistance between winding and core is more than 50 Megohms tested at 500 volts.

The inductance is not less than 8.0 H. at 100 milliamps and 50 cycles.

### Electrolytic Condensers.

There are two types of electrolytic condensers in the receiver :—

1. 8—8—8  $\mu$ F (peak working volts 400 D.C.). The capacity of each section is not less than 8.0  $\mu$ F. The leakage current is not more than 1.0 milliamps.
2. 25  $\mu$ F (peak working volts 25 D.C.). The capacity is not less than 25  $\mu$ F. The leakage current is not more than 0.1 milliamps.

**Gain Controls.**

The H.F. gain control is 2,000 ohms  $\pm 20\%$ . The L.F. gain control is 0.5 megohms  $\pm 20\%$ . A test for "noisiness" should be applied to these two potentiometers.

**Resistors.**

All resistors to have a tolerance of  $\pm 20\%$  except where otherwise specified.

**Condensers.**

All fixed condensers (except those in sub-assemblies and covered by tests on the latter) to have a tolerance of  $\pm 15\%$ .

TABLE 9.

ELECTRICAL SPECIFICATION OF H.F. COIL ASSEMBLY.

Range and Circuit.	Resistance		Secondary Inductance		Primary inductance With core at max. $\pm 5\%$	Coupling. With core at max. $\pm 25\%$	Minimum Q when tuned		
	Primary $\pm 15\%$	Secondary $\pm 15\%$	Less core $\pm 2\%$	core at max. $\pm 15\%$			With 500 pF.	With 200 pF.	With 60 pF.
1 Ae. ..	2.5 $\Omega$	65 $\Omega$	13.6 mH	18 mH	50 $\mu$ H	0.25	40	40	35
1 HF. ..	1.2 $\Omega$	65 $\Omega$	13.6 ..	18 ..	13 ..	0.25	17	17	10
1 Mixer ..	1.2 $\Omega$	65 $\Omega$	13.6 ..	18 ..	13 ..	0.25	17	17	10
1 Osc. ..	3.0 $\Omega$	17 $\Omega$	1,300 $\mu$ H	1,870 $\mu$ H	100 ..	0.3			
2 Ae. ..	0.6 $\Omega$	20 $\Omega$	1,720 ..	2,480 ..	13 ..	0.3	55	55	40
2 H.F. ..	0.5 $\Omega$	20 $\Omega$	1,720 ..	2,480 ..	2 ..	0.3	55	55	40
2 Mixer ..	0.5 $\Omega$	20 $\Omega$	1,720 ..	2,480 ..	2 ..	0.3	55	55	40
2 Osc. ..	2.5 $\Omega$	10 $\Omega$	440 ..	635 ..	60 ..	0.25			
3 Ae. ..	0.5 $\Omega$	4.5 $\Omega$	178 ..	256 ..	2.5 ..	0.3	80	80	60
3 H.F. ..	0.2 $\Omega$	4.5 $\Omega$	178 ..	256 ..	1.0 ..	0.25	80	80	60
3 Mixer ..	0.2 $\Omega$	4.5 $\Omega$	178 ..	256 ..	1.0 ..	0.25	80	80	60
3 Osc. ..	1.5 $\Omega$	4.5 $\Omega$	95 ..	137 ..	22 ..	0.25			
4 Ae. ..	0.1 $\Omega$	1.5 $\Omega$	22 ..	33 ..	1.0 ..	0.3	80	80	60
4 HF. ..	0.15 $\Omega$	1.5 $\Omega$	22 ..	33 ..	2.0 ..	0.35	80	80	60
4 Mixer ..	0.15 $\Omega$	1.5 $\Omega$	22 ..	33 ..	2.0 ..	0.35	80	80	60
4 Osc. ..	0.4 $\Omega$	0.6 $\Omega$	16.6 ..	25 ..	4.0 ..	0.3			
5 Ae. ..	0.1 $\Omega$	0.2 $\Omega$					80	80	60
5 HF. ..	0.15 $\Omega$	0.2 $\Omega$					80	80	60
5 Mixer ..	0.15 $\Omega$	0.2 $\Omega$					80	80	60
5 Osc. ..	0.2 $\Omega$	0.2 $\Omega$							
6 Ae. ..	0.15 $\Omega$	0.1 $\Omega$					60	60	60
6 HF. ..	0.2 $\Omega$	0.1 $\Omega$					60	60	60
6 Mixer ..	0.2 $\Omega$	0.1 $\Omega$					60	60	60
6 Osc. ..	0.15 $\Omega$	0.1 $\Omega$							

Note. Inductances measured on 1,000 cycle bridge.

TABLE 10.

## ELECTRICAL SPECIFICATION OF I.F. AND B.F.O. COIL ASSEMBLIES.

Assembly	Circuit	Tags	Resistance $\pm 15\%$	Inductance $\pm 5\%$ with core at max.	Q $\pm 15\%$	Position 1 Coupling $\pm 15\%$	Position 2 Coupling $\pm 15\%$
I.F.1 .. ..	Anode Neut.	3—5	3.5 $\Omega$ 5.0 $\Omega$	364 $\mu\text{H}$	105		
I.F.2 .. ..	Grid Grid Tap.	5—7 Sc. Lead —7	3.5 $\Omega$ 2.0 $\Omega$	364 ..	105		
I.F.3 and 4 ..	Primary Pri. Tap. Secondary Sec. Tap. Coupling	5—7 6—7 Sc. Lead —2 1—2	3.5 $\Omega$ 2.0 $\Omega$ 3.5 $\Omega$ 2.0 $\Omega$ 0.2 $\Omega$	364 .. 364 ..	105 105	0.005	0.02
I.F.5 .. ..	Primary Pri. Tap. Secondary Sec. Tap.	5—7 6—7 2—3	3.5 $\Omega$ 2.0 $\Omega$ 3.5 $\Omega$ 2.0 $\Omega$	364 .. 364 ..	105 105	0.005	
B.F.O. ..	Osc.		3.5 $\Omega$	364 ..	75		

Note. Screening covers must be removed from I.F.1 and B.F.O. Units to obtain access to certain windings owing to inclusion of condensers in the connections to external tags.

**Main Tuning 4-Gang Condenser. Angle—Capacity Law.**

Each section of the condenser has the following angle-capacity law when measured on a comparison bridge, the minimum capacity having been balanced out when the condenser is set to 0 degrees and all other values measured as increments.

TABLE 11.

Angle of Condenser. (in degrees)	Capacity in pF.
0	0
20	10
60	61.5
100	160
140	279
180	431.5

Permissible tolerance  $\pm 1$  pF or  $\pm 1\%$  whichever is the greater.

**Main Tuning 4-Gang Condenser. Logging Scale—Capacity Law.**

The Logging Scale should be at 25 when condenser vanes are fully meshed.

Each section of the condenser should then conform to the following law when measured on a comparison bridge, the minimum capacity having been balanced out when the scale is at zero, and all other values being measured as increments.

TABLE 12.

<i>Scale.</i>	<i>Capacity in pF.</i>
0	0
3	11.5
6	35.8
8	57.8
11	102.2
14	162.3
17	235.0
19	285.5
22	362.0
25	431.5

Permissible tolerance  $\pm 1$  pF or  $\pm 1\%$  whichever is the greater.

SECTION 6.

INSTALLATION.

**Bench or Rack Mounting.**

If the receiver is to be fitted on a bench it should rest on the domes of the bottom plate, thus assisting ventilation.

If it is to be rack-mounted, the bottom plate should be reversed so that the domes are inwards.

**Connections for A.C. Supply, 50 c/s, 200/250 volts.**

See that all valves are correctly inserted and connected. Insert the A.C./D.C. heater link firmly in the sockets marked "A.C."

Insert the mains fuse firmly in the appropriate sockets on the top of the mains transformer to suit the voltage of supply.

When renewing the fuse the wire should be rated to fuse at a current of 2 amps. This may be 29 SWG alloy-tin wire, or 43 SWG copper as a temporary substitute.

The total power taken by the receiver is 85 watts. Connect the mains socket by a 3-wire cable to the mains supply as shown in Fig. 15, and plug in to the receiver. The terminals on the drawing are as seen from the back. It should be noted that the terminal marked "E" on the drawing of the socket will make contact with the plug which is joined to the chassis and earth terminal of the receiver, and that if this wire is omitted and the chassis is not effectively earthed elsewhere an alternating voltage will appear on the chassis when the mains are connected, because of the suppressor condensers (C90, or C110 and C111) connected internally.

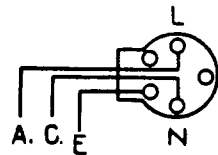

Fig. 15.

Socket Wiring for A.C. Mains.

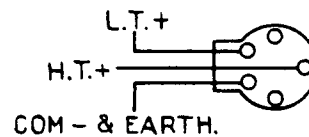

Fig. 16.

Socket Wiring for Independent Supplies.

The ON/OFF switch should be to OFF when connecting supplies.

**Operating the Receiver on D.C. Supplies.**

The receiver may be operated entirely on batteries : or from a 6 volt battery supplying all valve heaters, and driving a rotary converter providing the H.T. voltage.

**Connections for H.T. and L.T. Battery working.**

See that all valves are correctly inserted and connected. Insert the A.C./D.C. heater link firmly in the sockets marked "D.C."

Connect the supply socket to the H.T. and L.T. batteries by three wires as shown in Fig. 16, the negative terminals being made common.

As the supplies cannot be switched off on the receiver when operating on D.C. a suitable switch should be provided externally. It should be broken whilst plugging the supply socket on to the receiver. The voltage and current requirements are :—

- L.T. Battery* 6 volts, 4 amps.
- H.T. ..* 160 to 250 volts, 60 to 100 mA.

### **Connections when using Rotary Converter Unit, AP.2702.**

Drg. WZ.1960/C, page 45, shows the rotary converter and L.T. battery connections. The unit comprises a rotary converter, delivering 80 milliamps at 190 volts, D.C. ; low-pass filters in the input and output circuits, to prevent electrical interference to the receiver and others in the neighbourhood ; and a double-pole switch and 15 amps fuse, controlling the L.T.+ to the receiver and L.T.+ to the motor ; the whole mounted on a shallow inverted tray, over which there fits a lid incorporating the necessary screening compartments. The total current taken from the battery is about 8 amps.

Put the double-pole switch to OFF. See that the fuse is intact. Spare fuse wire is provided in an envelope, AP.2708.

Lift the hinged flap and remove the battery and receiver leads. Note the polarity shown on the labels of the battery leads and connect up to the battery. The supply socket on the receiver leads should be connected as in Fig. 16. Plug this on to the receiver.

Insert the A.C./D.C. heater link in the sockets marked " D.C." and see that all valves are correctly inserted and connected before switching on.

### **Aerial Connections.**

Figs. 17, 18 and 19, page 51, show the rear terminal boards on the various editions of the receiver. It will be seen that on certain models the aerial and dipole connections are brought out to pillar or button terminals, enabling a balanced dipole aerial or balanced feeder pair to be connected if desired, or alternatively an open aerial or an unbalanced feeder.

For balanced feeders or dipole aerial connect one wire to each of the terminals marked " D ". The input impedance is of the order of 100 ohms, and is a suitable termination for 75 ohms and 100 ohms feeders.

For unbalanced feeders connect the earthed wire to one " D " terminal and to the " E " terminal, and the live wire to the other " D " terminal.

For most types of open wire aerials connect to one " D " terminal and earth the other, as for unbalanced feeders. In certain circumstances, as, for example, a very short aerial, the " A " terminal may be used instead of " D ".

Where the aerial or feeder connection is by screened cable, the screening should be continued as near as possible to the aerial terminal, and the sheath strapped directly to the " E " terminal.

On CR.100/2 and CR.100/5 models the aerial or feeder is connected by screened cable and plug and socket, there being one socket marked " A " and one marked " D ". As in the case of other editions of the receiver most aerials and coaxial feeders will be suited best by connecting to the " D " socket.

### **Side Tone Facility (Type CR.100/2 only).**

If the receiver is to be operated independently of any transmitting equipment, the shorting plug of the side-tone facility should be inserted firmly in its socket.

If it is required to desensitize the receiver when transmitting, the shorting plug should be withdrawn and a screened pair cable from the transmitter relay (or insulated back contacts of the morse key) connected to the plug, and inserted instead. A suitable cable and plug are supplied with the receiver.

The potentiometer R57 (see Fig. 20, page 53) should be adjusted with the operating key pressed so that the operator hears the transmitter at a convenient level.



SECTION 7.

COMPONENT PARTS LIST FOR RECEIVER.

For References in Column 1, see Drawing WZ.1943, page 47

CONDENSERS

<i>Ref.</i>	<i>Nominal Values</i>
C.1	Special 4 Gang Tuning Condenser 437.5pF Sweep Dwg. W.Q. 3240 Sh. 1
C.2	
C.3	
C.4	
C.5	350pF Dubilier Type S.690W $\pm$ 2%
C.6	As C.5
C.7	"
C.8	"
C.9	"
C.10	"
C.11	"
C.12	"
C.13	20pF W.I.S.1540 Neut. Cond.
C.14	25pF $\pm$ 2 Erie P.120M.
C.21	H.F. Circuit Trimmers Wright & Weaire 5-50 pF
C.22	As C.21
C.23	"
C.24	"
C.25	"
C.26	"
C.27	"
C.28	"
C.29	"
C.30	"
C.31	"
C.32	"
C.33	Osc. Circuit Trimmers Wright & Weaire 5-50 pF
C.34	As C.33
C.35	"
C.36	P.120K. Value to be determined on Test
C.37	P.120K. Value as determined on Test
C.38	25 pF Wingrove & Rogers Type C.802 Aerial Trimmer
C.39	P.120K. Value to be determined on Test
C.40	10 pF Wingrove & Rogers Type C.802 B.F.O. Cond.
C.41	2,000 pF Dubilier Type S.691W
C.42	420 pF Dubilier Type S.690W
C.43	7 pF $\pm$ 1 Erie P.120K
C.44	55 pF $\pm$ 1 Erie P.120D
C.45	150 pF $\pm$ 1% Dubilier Type S.690W
C.46	460 pF $\pm$ 1% Dubilier Type S.690W
C.47	1,190 pF $\pm$ 2% Dubilier Type S.691W
C.48	3,400 $\pm$ 2% Dubilier Type S.691W
C.49	10,000 pF $\pm$ 2% Dubilier Type S.691W
C.50	"
C.51	10 pF $\pm$ 1 Erie P.120K
C.52	0.1 $\mu$ F Dubilier Type 24901/1A
C.53	As C.52
C.54	0.1 $\mu$ F Dubilier Type P.991W
C.55	As C.52
C.56	"
C.57	As C.54
C.58	As C.52
C.59	"
C.60	"
C.61	"
C.62	"
C.63	"
C.64	"
C.65	"



**CONDENSERS (contd.)**

<i>Ref.</i>	<i>Nominal Values</i>
C.66	As C.52.
C.67	"
C.68	"
C.69	"
C.70	"
C.71	"
C.72	"
C.73	"
C.74	"
C.75	"
C.76	"
C.77	"
C.78	1 $\mu$ F Muirhead Type 134JA
C.79	As C.78
C.80	0.1 $\mu$ F T.C.C. Type 545
C.81	As C.80
C.82	0.01 $\mu$ F Dubilier Type 24901/4A
C.83	500 pF Dubilier Type 690W
C.84	0.01 $\mu$ F Dubilier Type 691 W
C.85	100 pF Dubilier Type 635
C.86	30 pF $\pm$ 2 Erie P.120M
C.87	25 $\mu$ F 25v. Wkg. Dubilier Type 4001
C.88	As C.87
C.89	8-8-8 $\mu$ F T.C.C. Electrolytic 400 v.
C.90	
C.91	0.1 $\mu$ F Dubilier Type 24901/4A
C.92	As C.85
C.93	"
C.94	"
C.95	500 pF Dubilier Type 635
C.96	2,000 pF 500 v. D.C. Wkg. A.H. Hunt Type L.6/4
C.97	As C.95
C.103	Plessey Mica Trimmer Type 1760/7
C.104	As C.103
C.105	3,100 pF $\pm$ 2% Dubilier Type S.691W
C.106	As C.105
C.110	.01 $\mu$ F T.C.C. Type M.4
C.111	As C.110

} Replacing C.90 tubular type  
} Suppressor Condenser

**RESISTANCES**

<i>Ref.</i>	<i>Preferred Value in Ohms</i>	<i>Original Specified Value in Ohms</i>
R.1	47,000 Erie RMA No. 9	50,000
R.2	As R.1	50,000
R.3	22,000 Erie RMA No. 9	20,000
R.4	As R.1	50,000
R.5	"	50,000
R.6	47 Erie RMA No. 9	50
R.7	22,000 Erie RMA No. 1	20,000
R.8	As R.1	50,000
R.9	20,000 Painton Type P.301	20,000
R.10	220,000 Erie RMA No. 9	200,000
R.11	On CR.100 & CR.100 2 470,000 RMA 9	500,000
	On CR.100 4 & CR.100 5 47,000 RMA No. 9	50,000
R.12	10,000 Erie RMA No. 9	10,000
R.13	2,200 Erie RMA No. 9	2,000
R.14	As R.13	2,000
R.15	"	2,000
R.16	"	2,000
R.17	"	2,000
R.18	4,700 Erie RMA No. 9	5,000
R.19	As R.18	5,000
R.20	39,000 Erie RMA No. 9	40,000

**RESISTANCES (contd.)**

<i>Ref.</i>	<i>Preferred Value in Ohms</i>	<i>Original Specified Value in Ohms</i>
R.21	As R.18	5,000
R.22	"	5,000
R.23	"	5,000
R.24	As R.3	20,000
R.25	100,000 Erie RMA No. 9	100,000
R.26	As R.25	100,000
R.27	1 Megohm Erie RMA No. 9	1 Megohm
R.28	1,200 Erie RMA No. 9	1,200
R.29	As R.12	10,000
R.30	470 Erie RMA No. 2	500
R.31	470,000 Erie RMA No. 9	500,000
R.32	As R.27	1 Megohm
R.33	390 Erie RMA No. 9	400
R.34	As R.33	400
R.35	"	400
R.36	"	400
R.37	"	400
R.38	"	400
R.39	10,000 Dubilier Type A.B.	10,000
R.40	As R.39	10,000
R.41	2,000 Potentiometer	2,000
R.42	500,000 Potentiometer	500,000
R.43	As R.25	100,000
R.44	As R.13	2,000
R.45	As R.3	20,000
R.46	"	20,000
R.47	3,300 Erie RMA No. 9	3,000
R.48	560 Erie RMA No. 9	600
R.49	As R.10	200,000
R.50	"	200,000
R.51	10 Erie RMA No. 9	10
R.52	As R.51	10
R.53	"	10
R.54	As R.25	100,000
R.55	2.2 Megohms Erie RMA No. 9	2 Megohms
R.56	As R.25	100,000
R.57	2,000 Potentiometer (CR.100 2 only)	2,000

**TRANSFORMERS.**

T.1	Mains Transformers W.Q.3244 Sh. 1
T.2	Output Transformer W.I.S.2578

**CRYSTAL**

Q.	Crystal. W.Q.3244 C Sh. 14
----	----------------------------

**SWITCHES.**

S.1	
S.2	
S.3	
S.4	H.F. Switch W.I.S.1197 Sh. 131
S.5	
S.6	
S.7	
S.8	
S.10	
S.11	
S.12	I.F. Switch W.I.S.1197 Sh. 133
S.15	
S.13	Operational Switch W.I.S.1197 Sh. 132
S.14	Mains Switch { Bulgin Type S.80T Fitted with Insulated Ring

#### INDUCTANCES.

L1-L.48. High Frequency Coils W.Q.3241 Sh. 1  
L.49-L.60 I.F. Coils W.Q.3242 Sh. 1  
L.61 I<sup>2</sup>H Choke W.Q.3244 Sh. 3  
L.62 Special Iron Core Inductance W.Q.3244 Sh. 13  
L.63 As L.62  
L.64 L.F. Choke 8 H 120 mA 225 Ω W.Q.3244 Sh. 4  
L.65 As L.64

#### VALVES.

V.1 to V.11 See page 9.

#### ILLUMINATING LAMPS.

IL.1 6.5 v. —.3A O.S.75 MES 12 mm. Round  
IL.2 6.5 v. —.3A O.S.75 MES 12 mm. Round

#### FUSES.

F.1 2 Amps. W.Q.3244 Sh. 1  
F.2 L.338 500mA

#### MISCELLANEOUS ITEMS.

<i>Description.</i>	<i>Drq. No.</i>
Cord for Pointer and Cylinder. No. 9 Cord (No. 5289 Allcock)	—
Dial-lamp Holder	W.I.S.2769
Grid Lead. screened	W.Q.3244 C Sh. 7 Ed.A
.. .. for V8	W.7646 C Sh. 1 Ed.A
.. .. unscreened. for Oscil- lator	W.Q.3244 C Sh. 7 Ed.B
Handle and Pointer for Band- change Switch	W.Sk.13620 Ed.B
Knob. small	W.Sk.13613 Sh. 1 Ed.L
.. medium	W.Sk.13619 Sh. 1 Ed.B
.. large. Tuning	W.8277C Sh. 1. Ed.A
.. medium. Tuning	W.Sk.14312 Sh. 1 Ed.B
Mains Socket 5 point. side entry	W.Sk.1904
.. Plug .. ..	W.C.P.393
Plug. Heater Link	W.Q.3244 C Sh. 18
Screws. P.K. self-tapping No. 4 .. B.H.	
Screws. P.K. self-tapping No. 8 .. B.H.	
Telephone Jack	W.I.S.3150 C Sh. 1 Ref. 1
Valve Holder (Amphenol)	W.I.S.1894
.. Screening Can.	W.I.S.2345
Wire flexible "Hamofil." 14.0076	—
Wire flexible "Telcothene" screened 23.004	—

## COMPONENT PARTS LIST FOR ROTARY CONVERTER.

For references in Column 1 see Drawing below.

### CONDENSERS.

Ref.	Description
C.1	4 $\mu$ F Dubilier 24681 Non-inductive
C.2	" " " " " "
C.3	1 $\mu$ F Muirhead 134J " "
C.4	" " " " " "
C.5	" " " " " "

### CHOKES.

CH.1	Ferranti RD.1472
CH.2	" " " "
CH.3	RD.1470
CH.4	WSK.3203 Edn.G.
CH.5	" " " "

### FUSE.

F.1	Sydlock 15A 1533 F.W.
-----	-----------------------

### SWITCH.

S.1	Arrow 10A D.P. WIS 2220
-----	-------------------------

### RESISTANCE.

R.1	Erie 5. $\Omega$ R.M.A.9
-----	--------------------------

### ROTARY CONVERTER.

Elect. Dyn. Con. WIS.1571 Sht.3. Input 6 V.. Output 190 V.,  
80 mA.

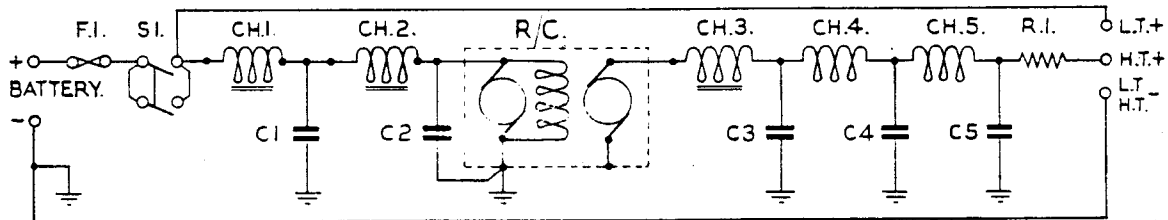



Diagram of Connections, Rotary Converter and Battery.

WZ1960.C



ALL SWITCHES SHOWN FULLY  
 COUNTER - CLOCKWISE.  
 CONTACTS AS VIEWED FROM FRONT.  
 FRONT ROTOR MARKED F  
 REAR ROTOR MARKED R.

 INDICATES SCREENED LEAD  
 WITH SCREENING EARTHED

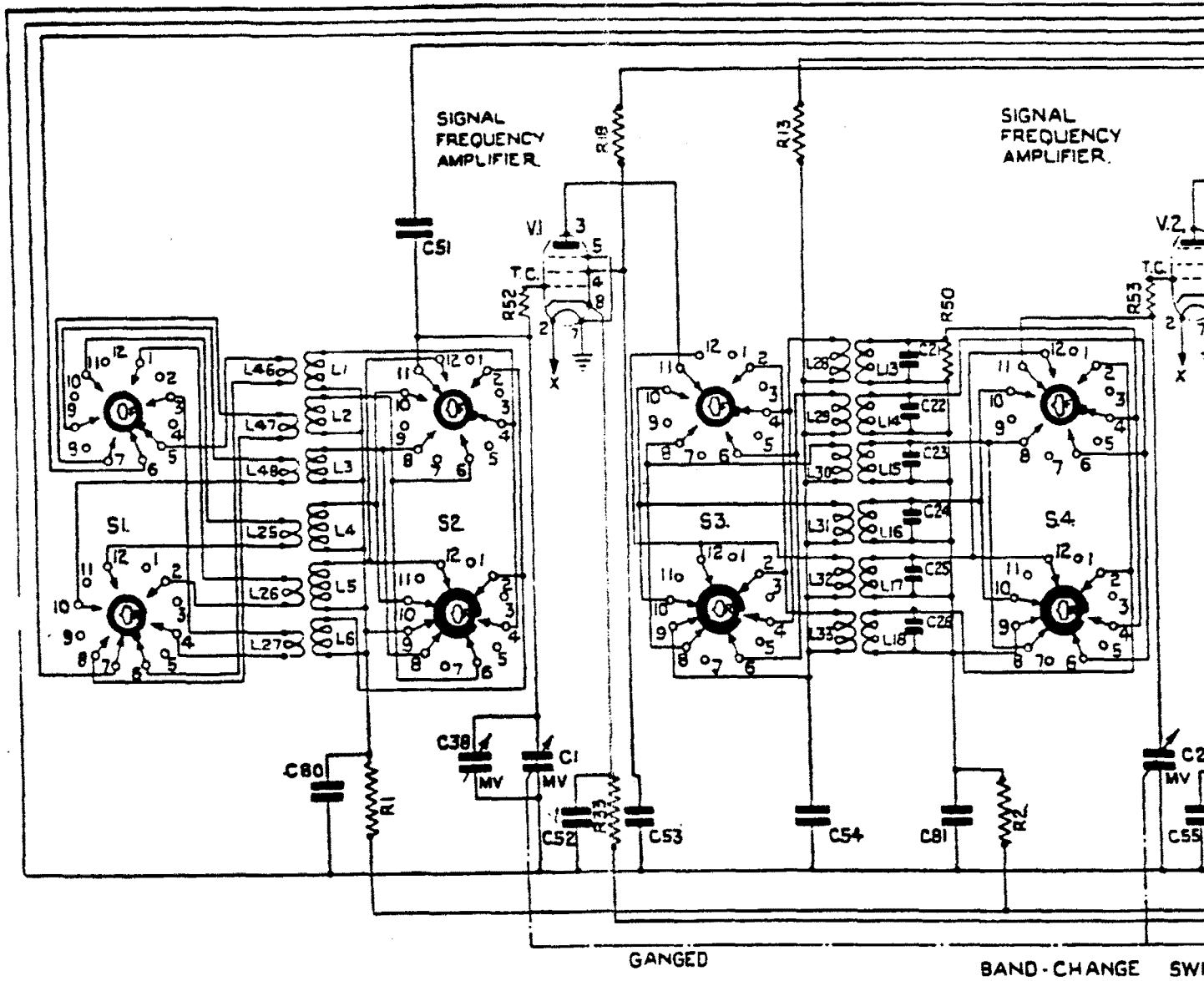
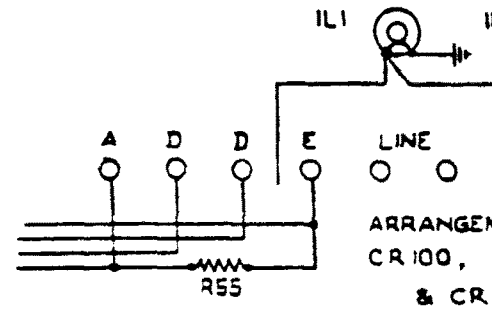

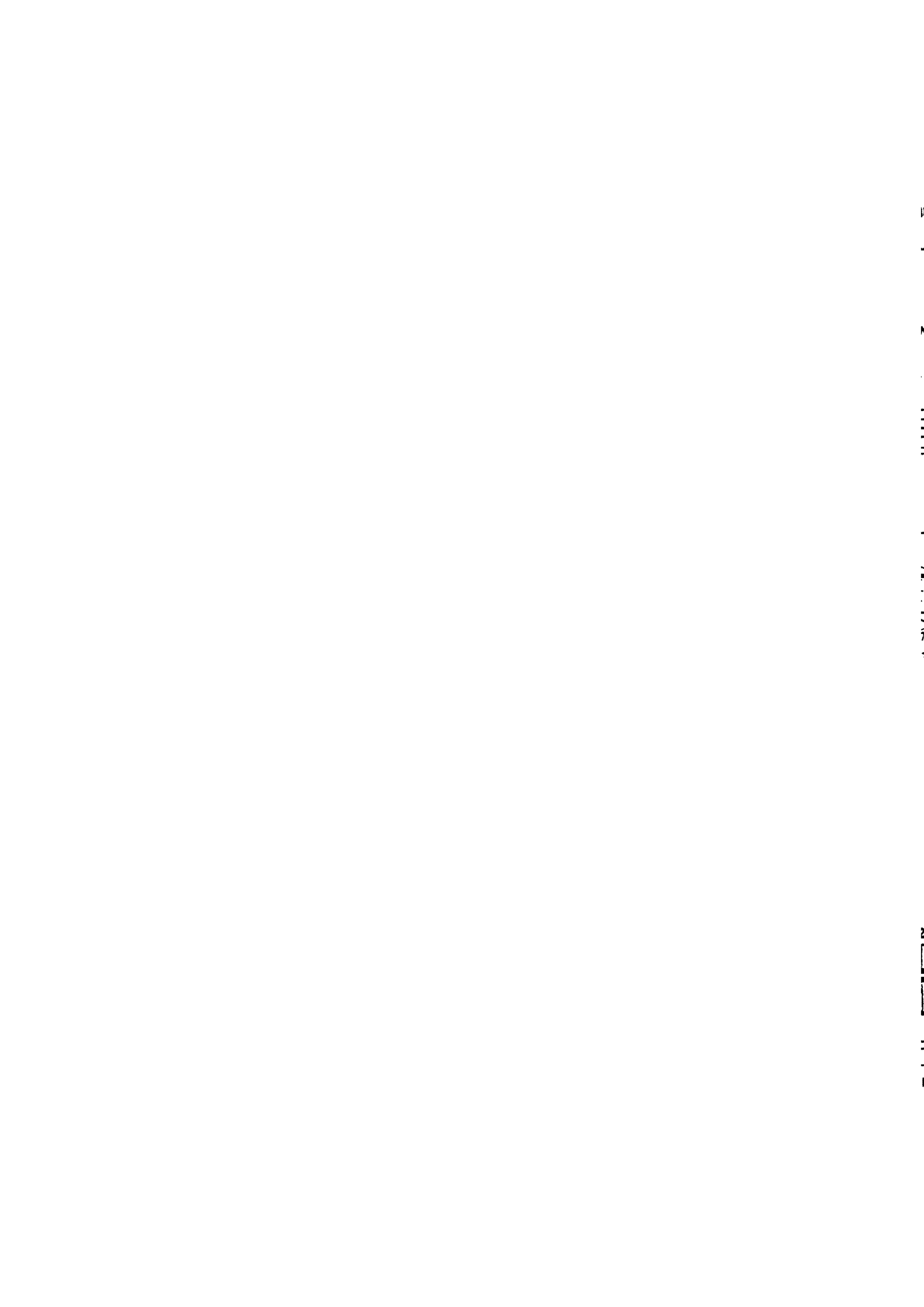

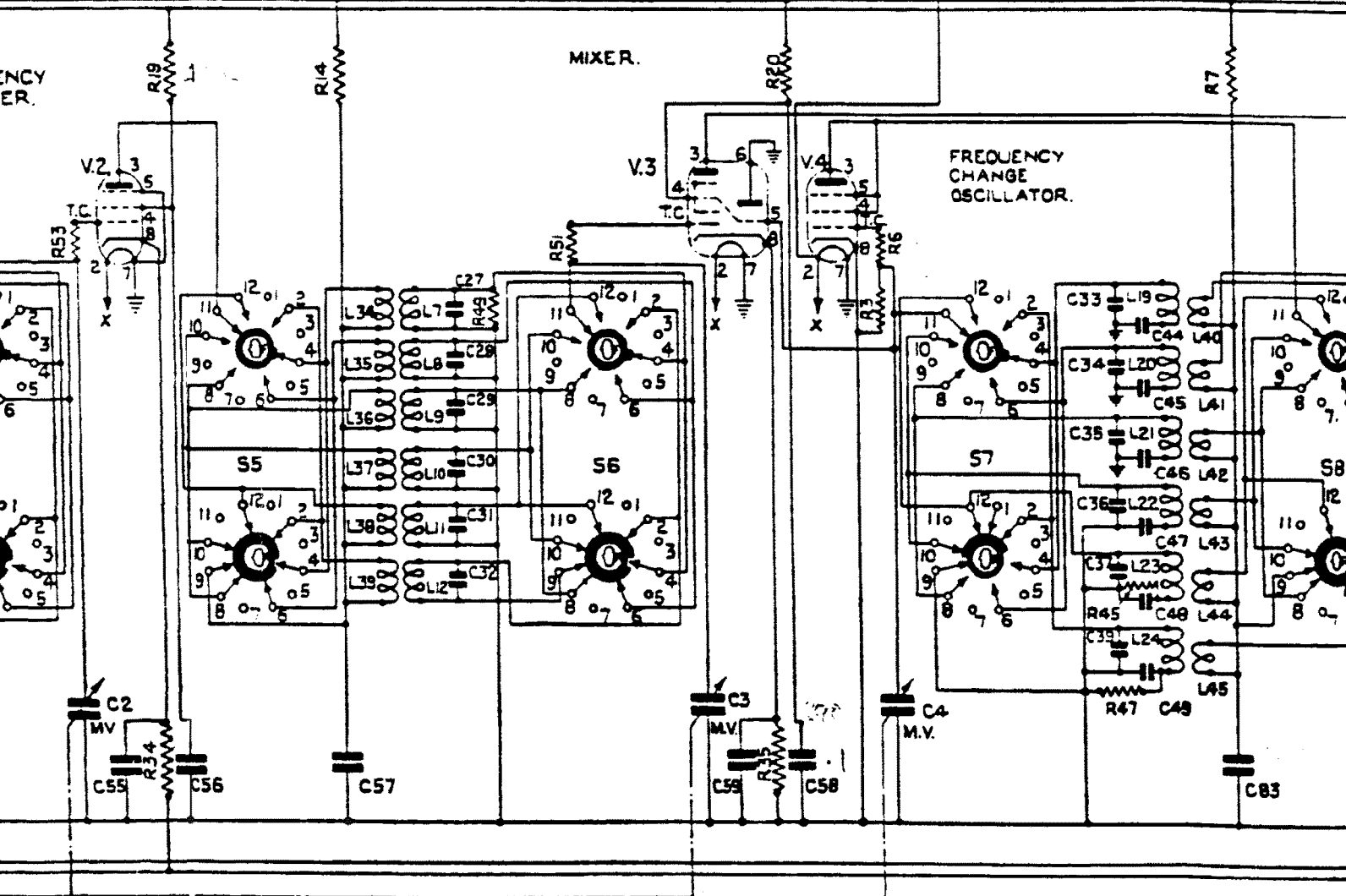
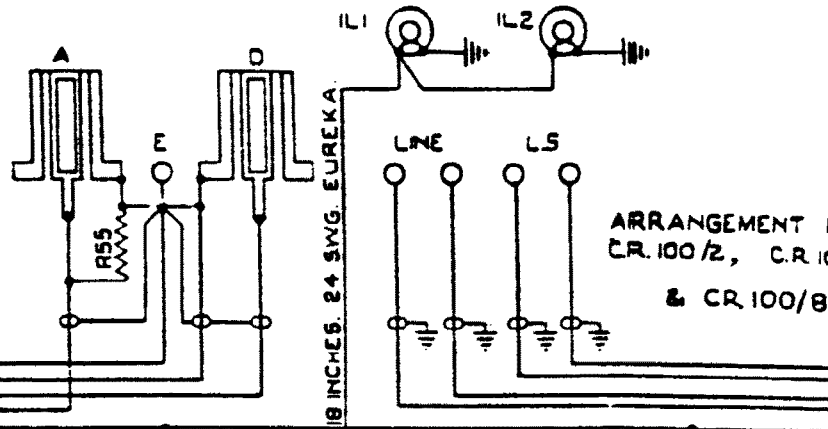
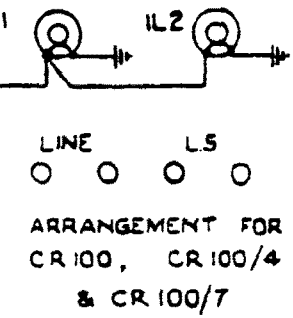

CHANGE SWITCH S1, S2, S3, S4, S5, S6, S7, S8.

GANGED



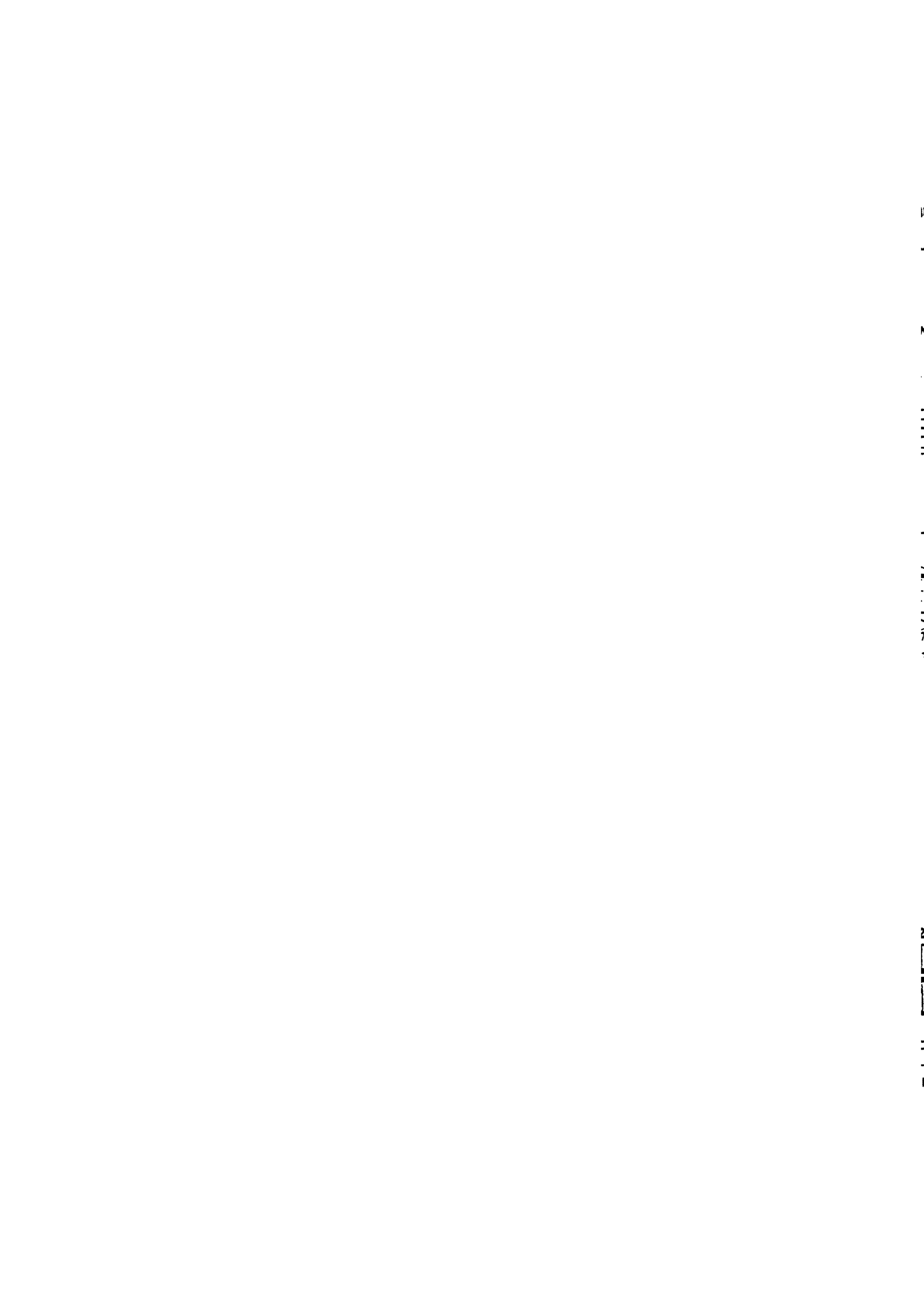

ARRANGEMENT FOR  
 10/2, C.R.100/5.  
 C.R.100/8

BEAT FREQUENCY OSCILLATOR

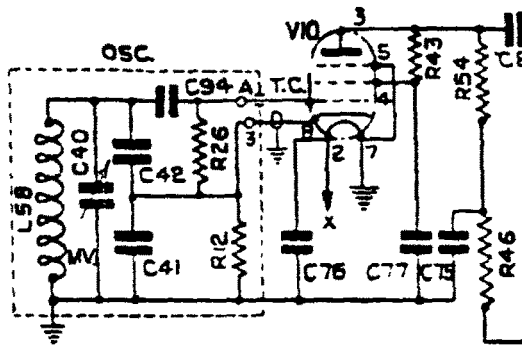

H.T. RECTIFIER.

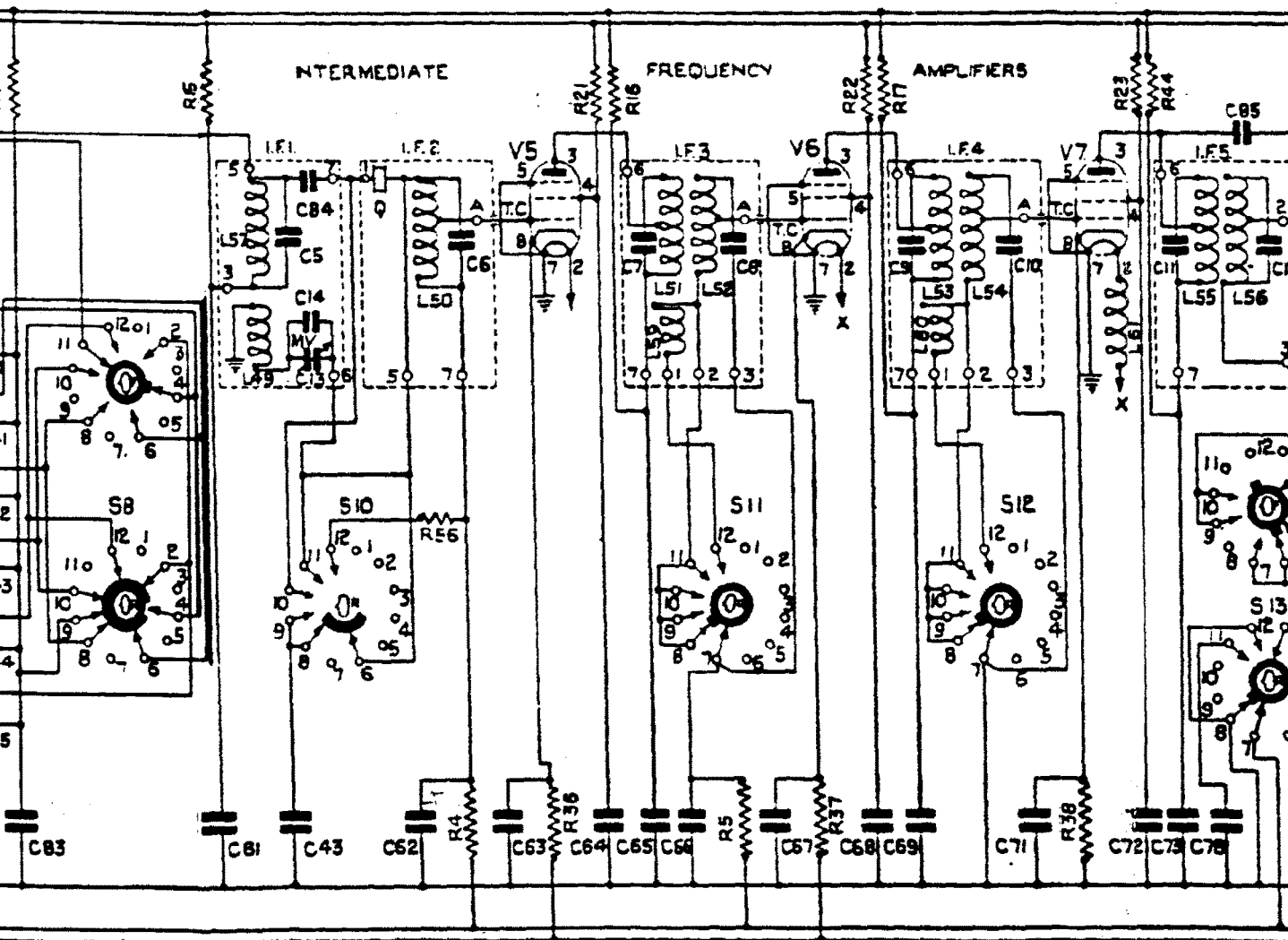
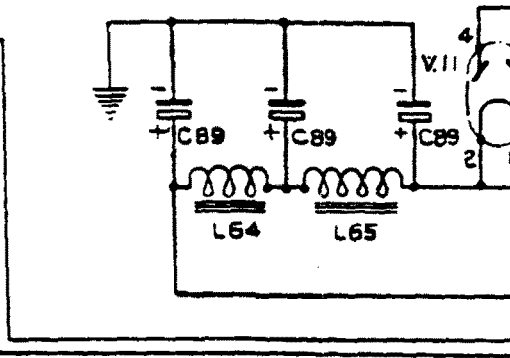

PASS-BAND SWITCH S10, S11, S12, S13

OPERATIONAL

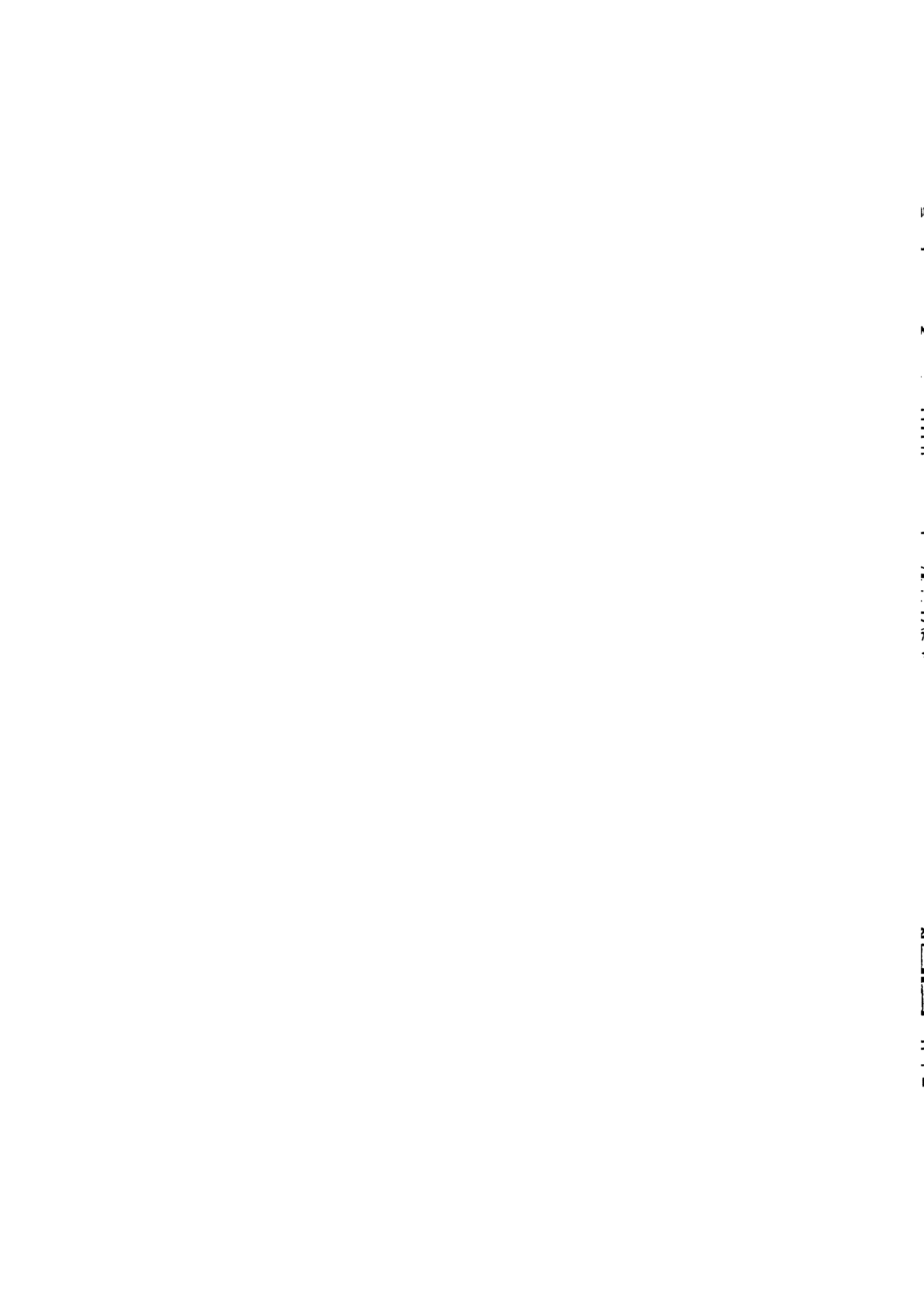

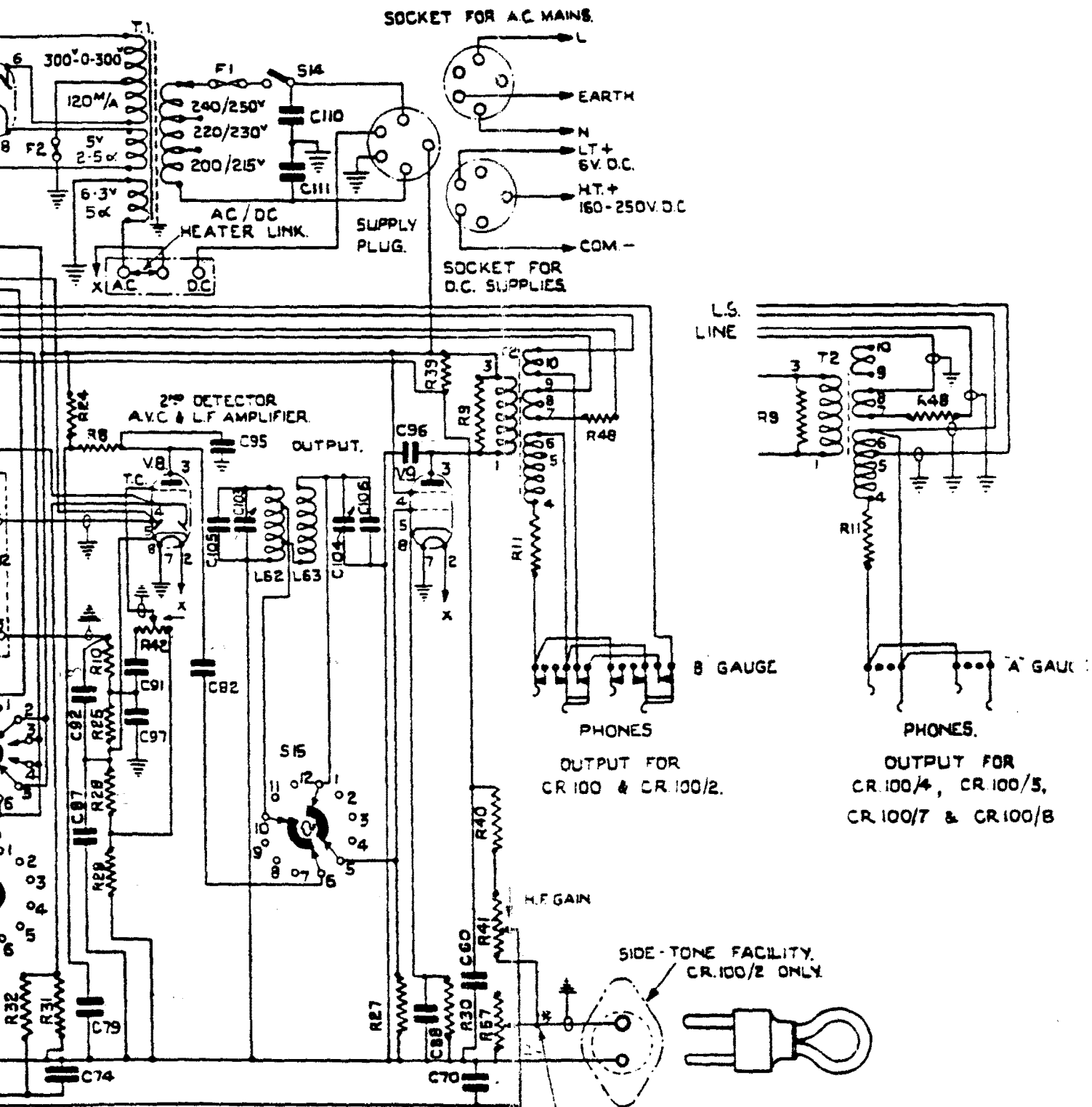

AL SWITCH S13.

\* THIS POINT EARTHED ON ALL MODELS EXCEPT CR.100/2.

WZ1943

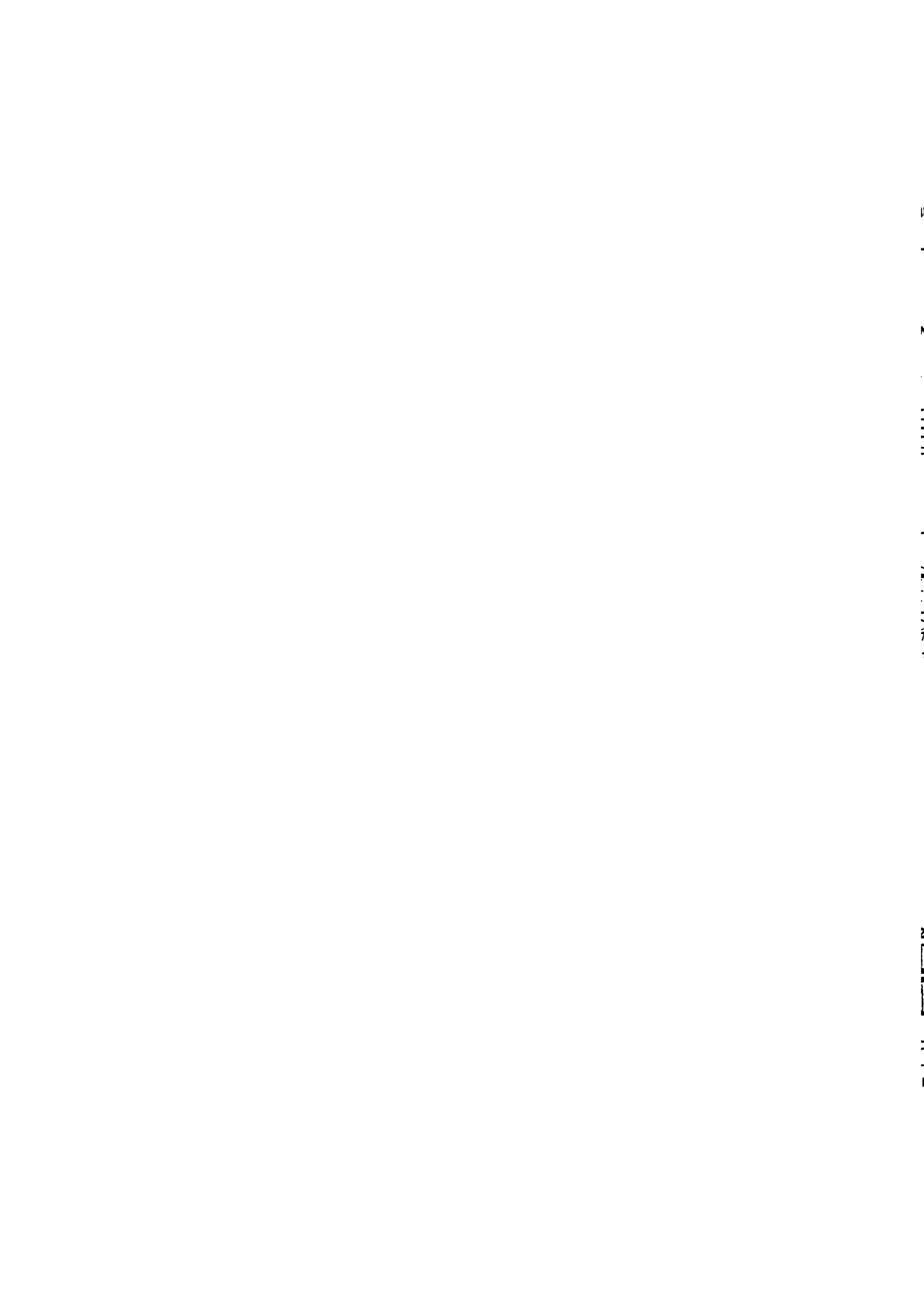

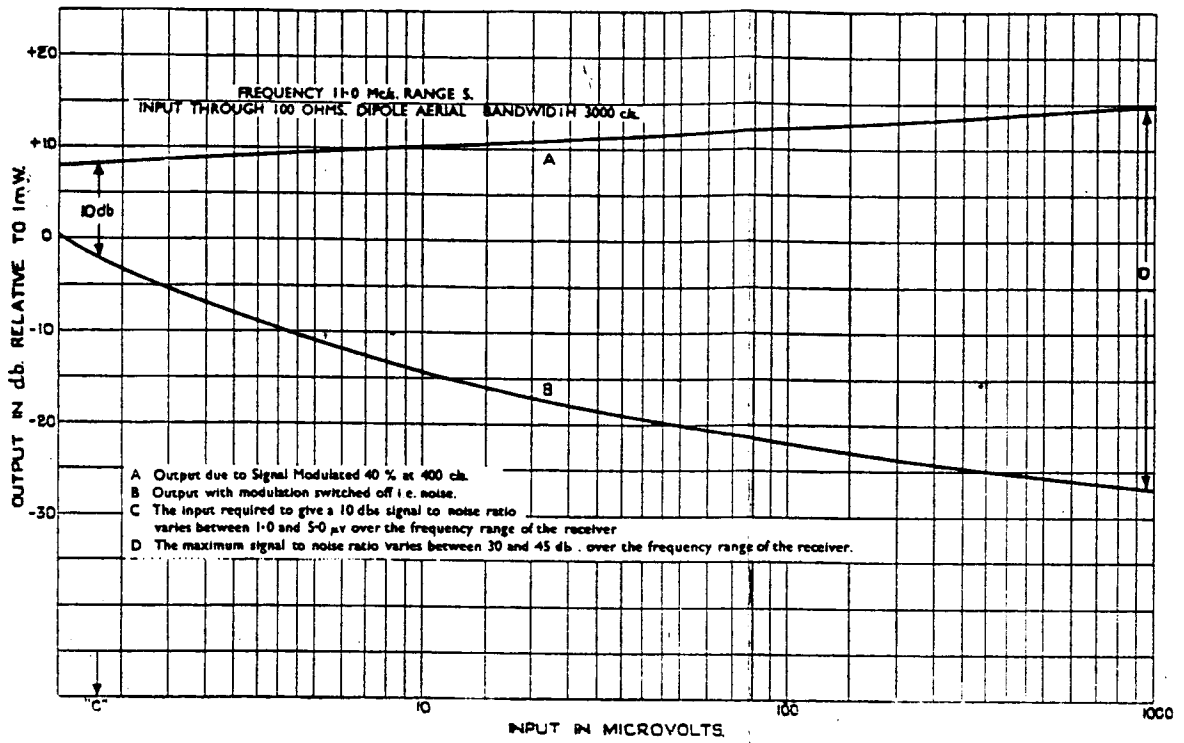

Fig. 4. A.V.C. Response Curves.

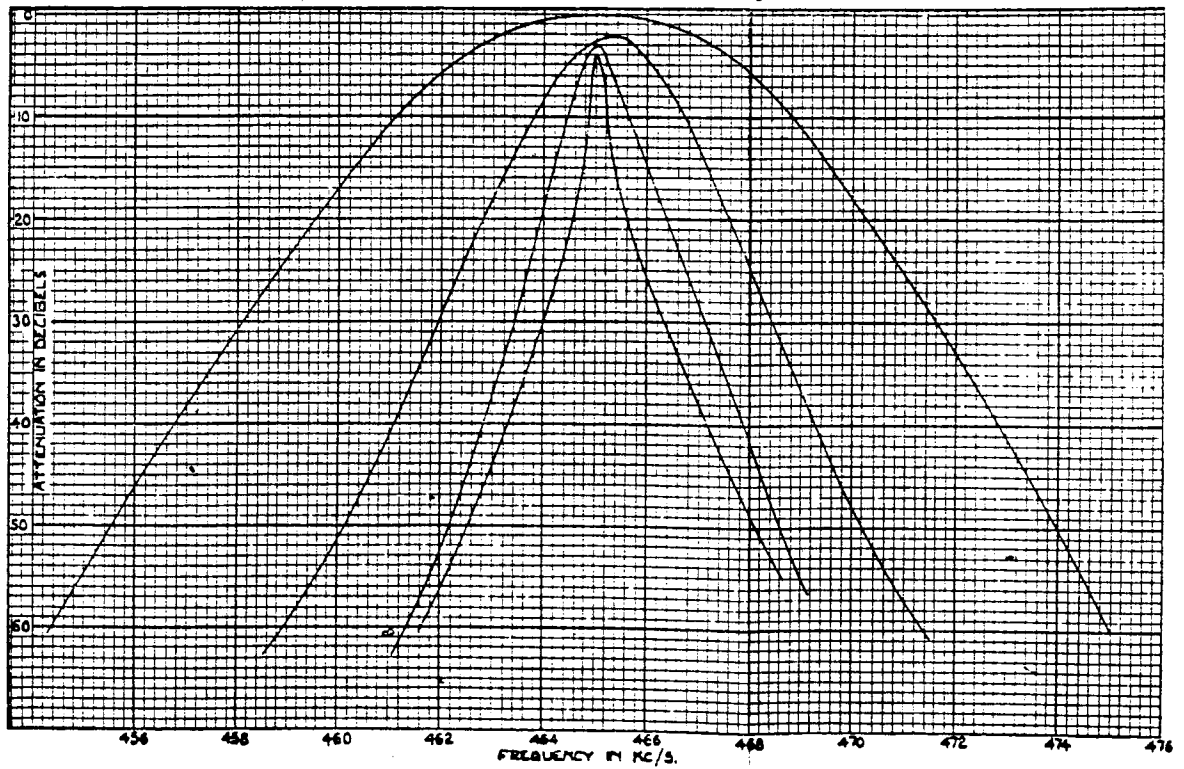

Fig. 5. I.F. Response Curves.

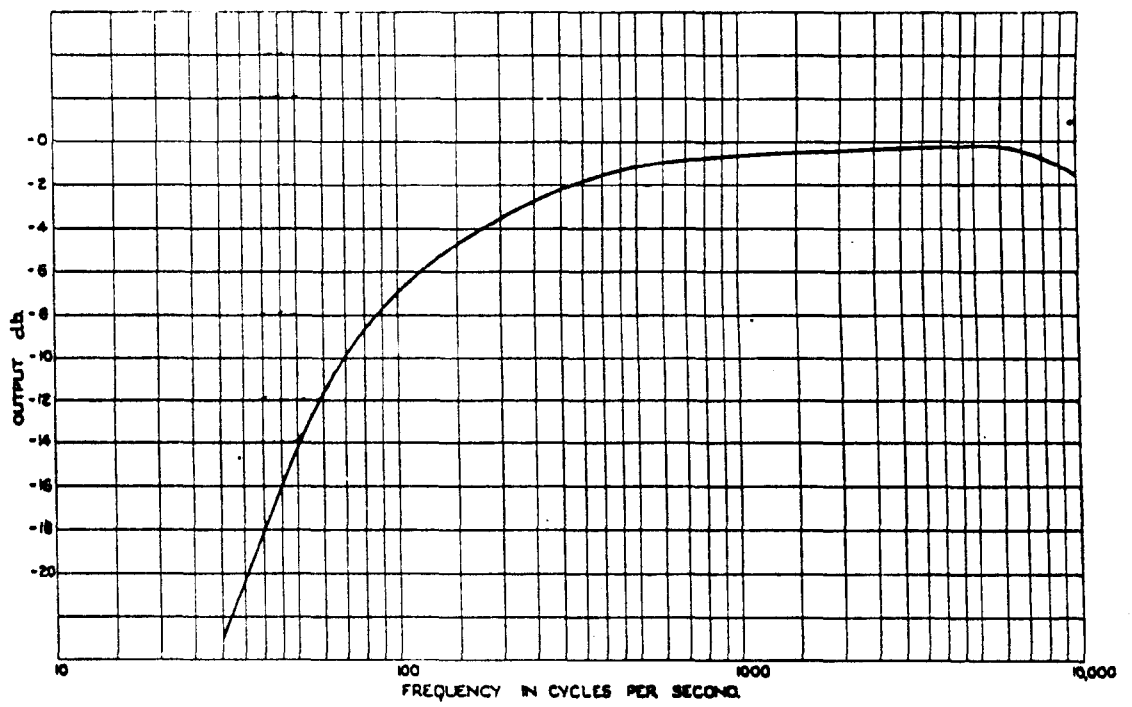

Fig. 6. Audio-frequency Response Curve.

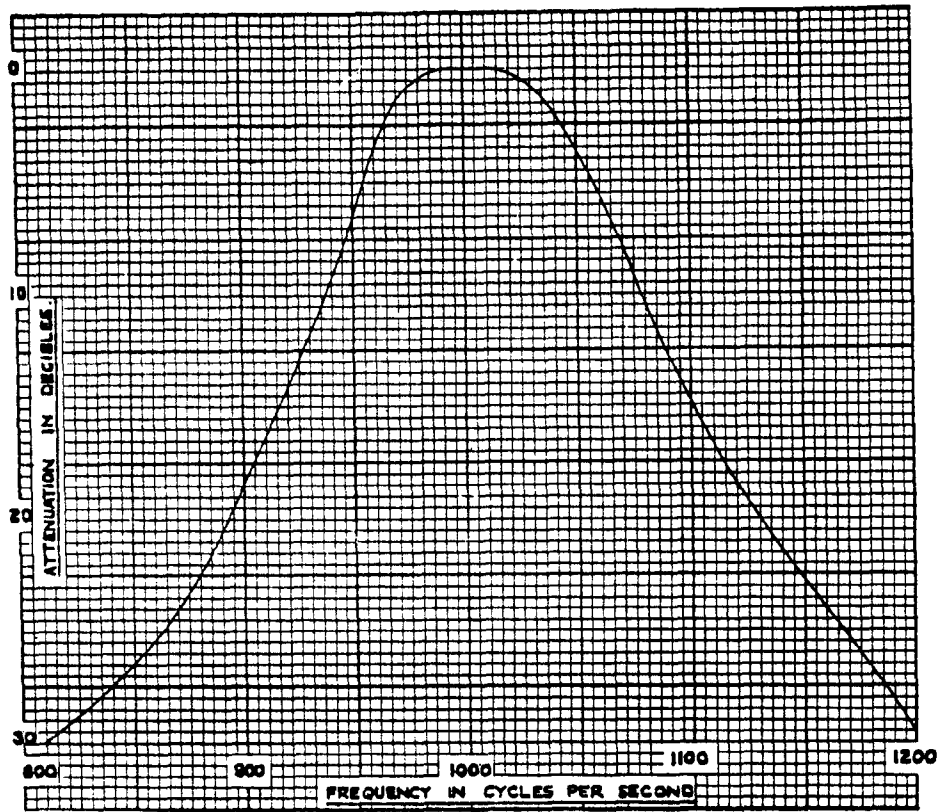

Fig. 7. L.F. Filter Response Curve.

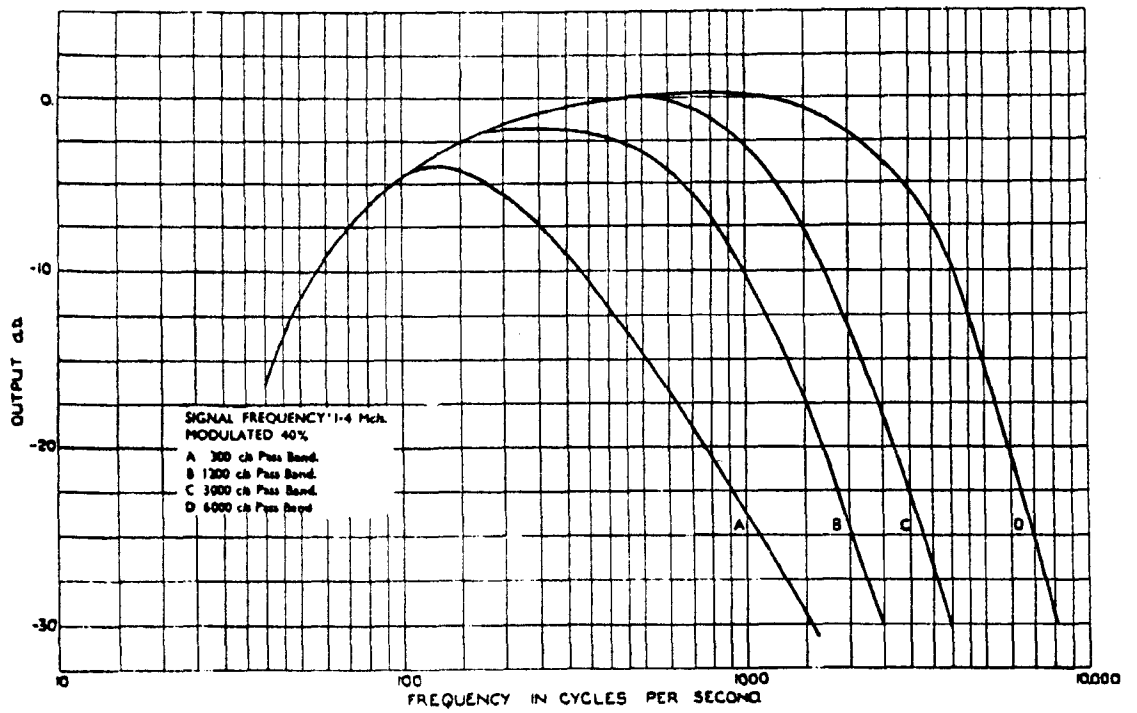

Fig. 8. Overall Fidelity Response Curves.



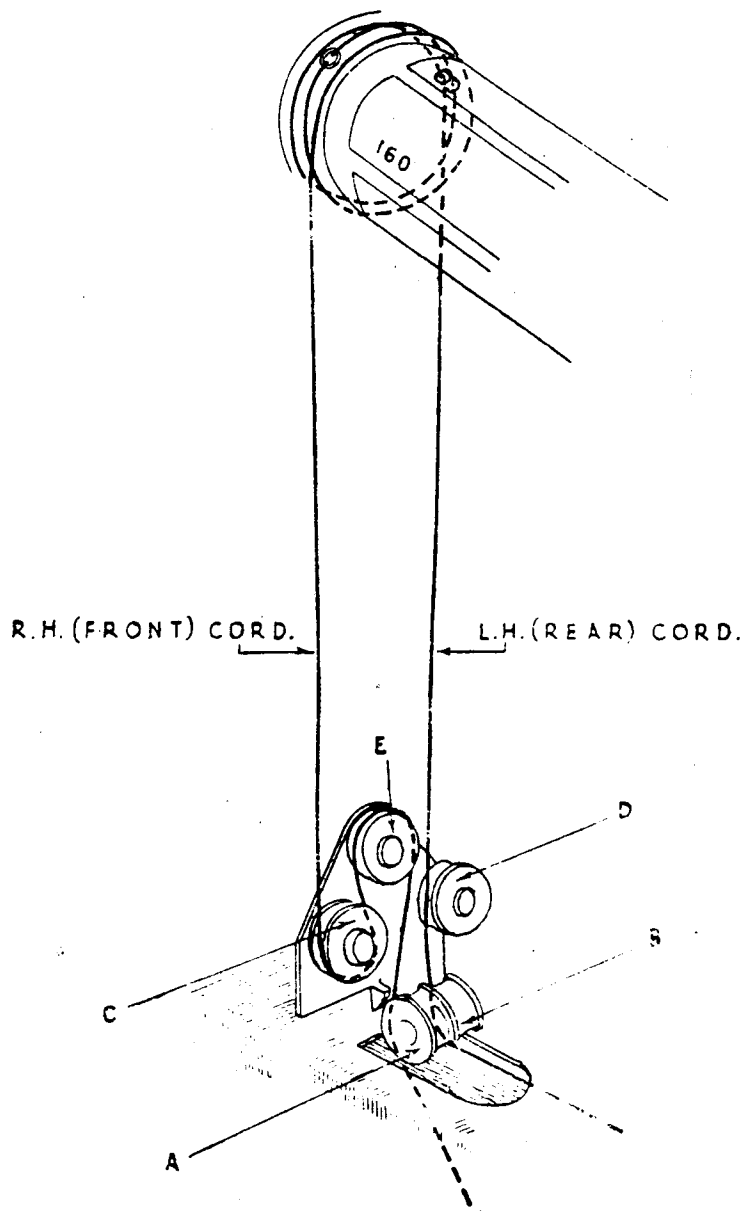

Fig. 11. Band-change Cord.

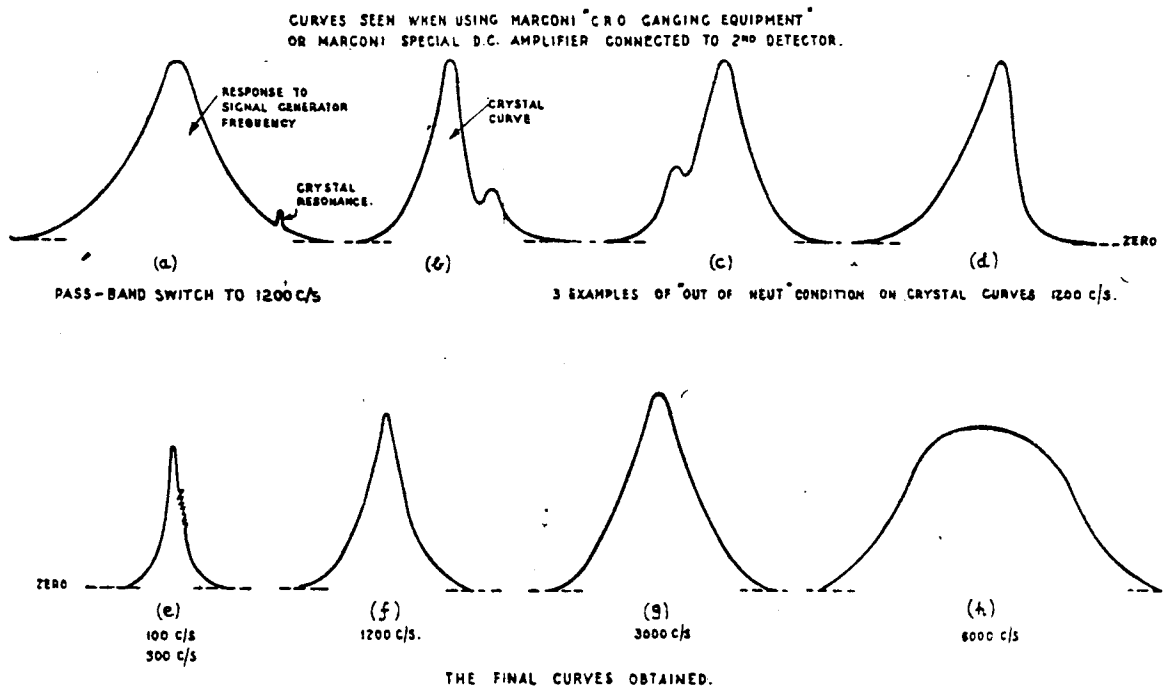

Fig. 13.

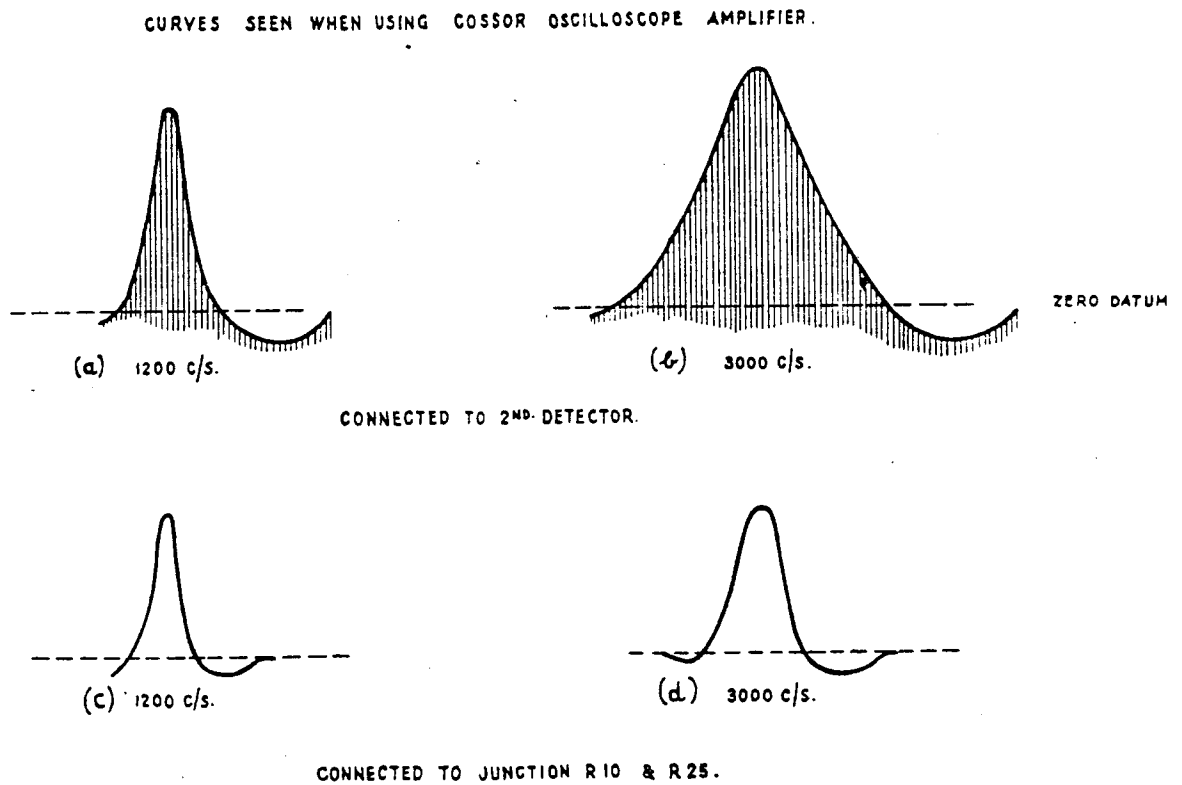
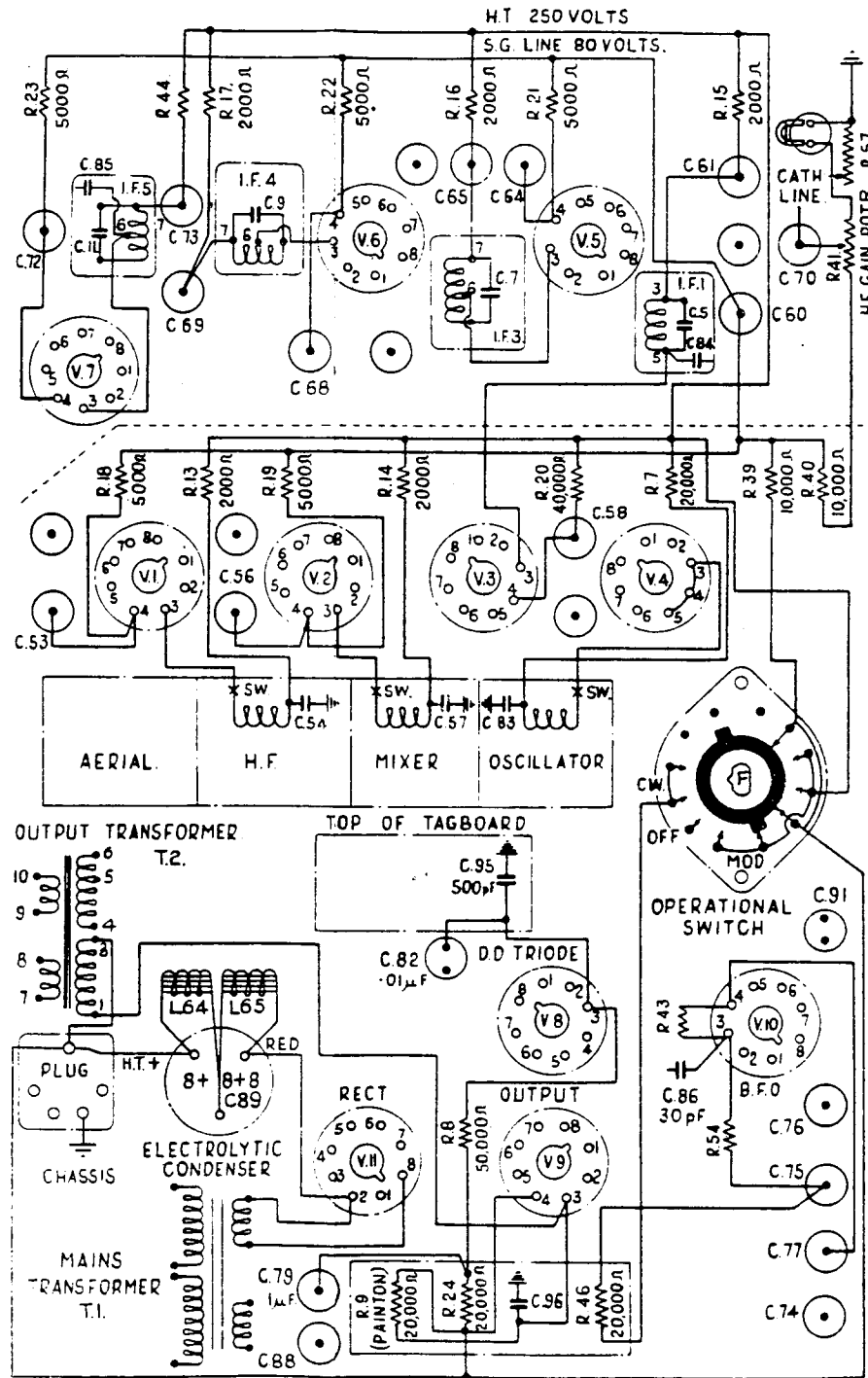

Fig. 14.

I.F. Response Curves (Oscilloscope).





H.T. Circuits.

WZ1948/C

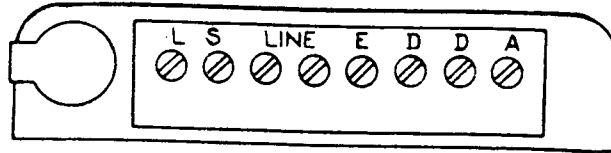

OTHER D TERMINAL TO BE EARTHED IF  
USING ONE D TERMINAL FOR AERIAL  
OR UNBALANCED FEEDER.

Fig. 17.

Rear Terminals of Types C.R.100 and CR.100/4 Receivers.

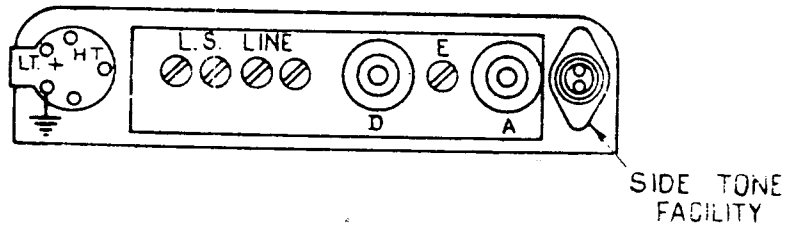

Fig. 18.

Rear Terminals of Type CR.100/2 Receiver.

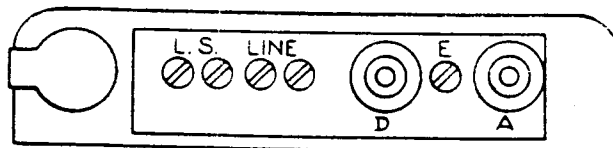

Fig. 19.

Rear Terminals Type CR.100/5 Receiver.

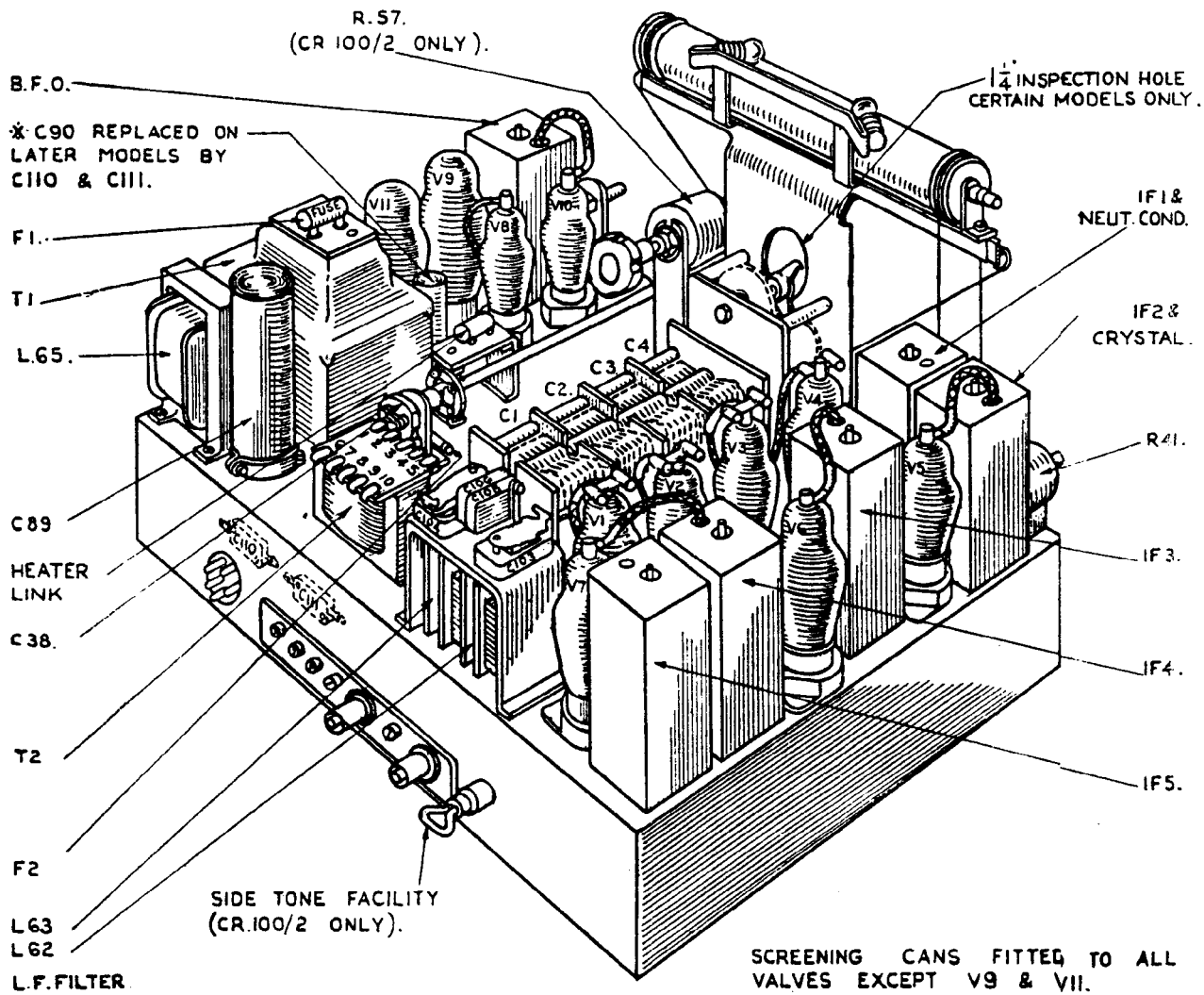

Fig. 20. TOP OF CHASSIS.

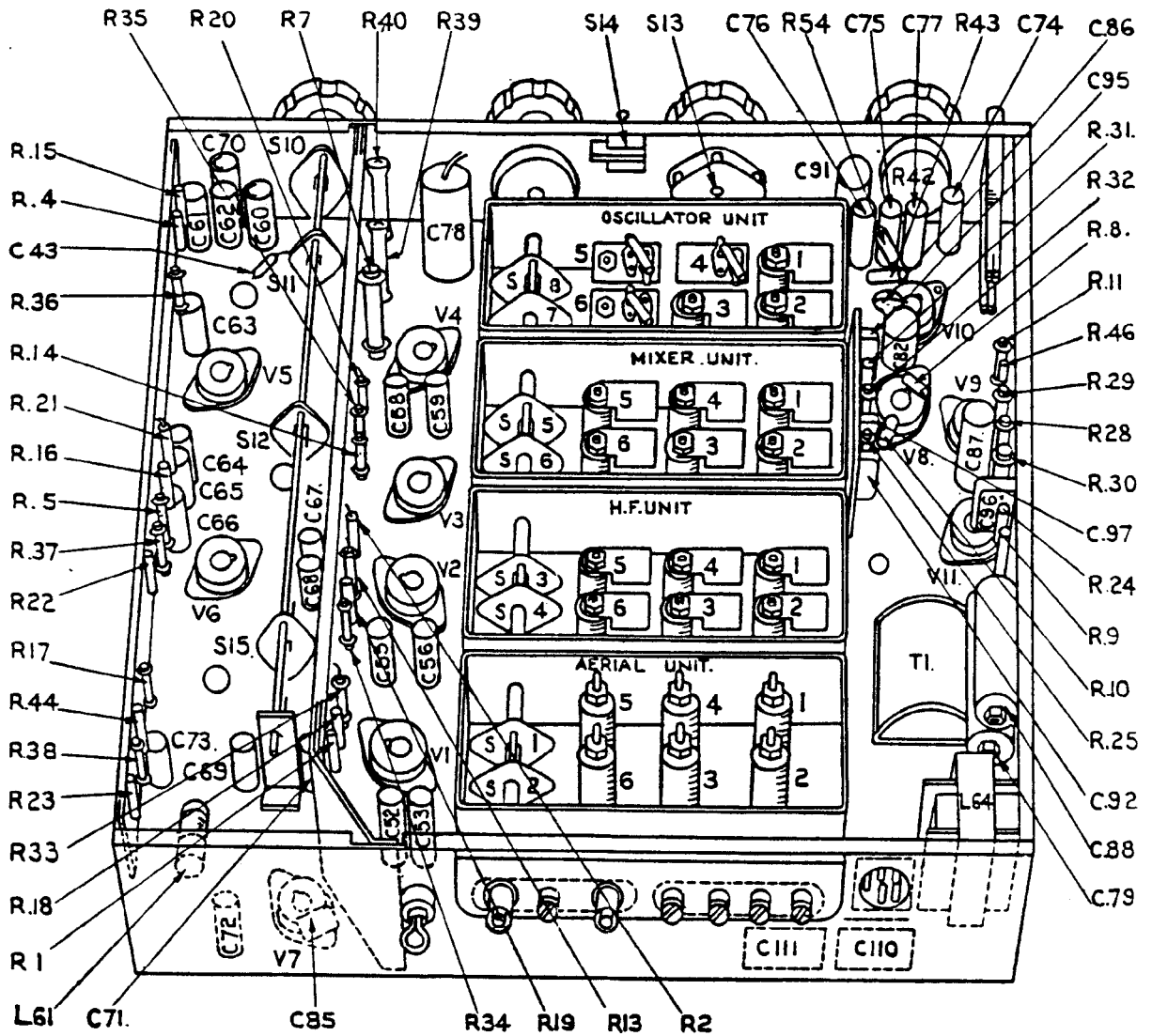

Fig. 21. UNDERNEATH OF CHASSIS.

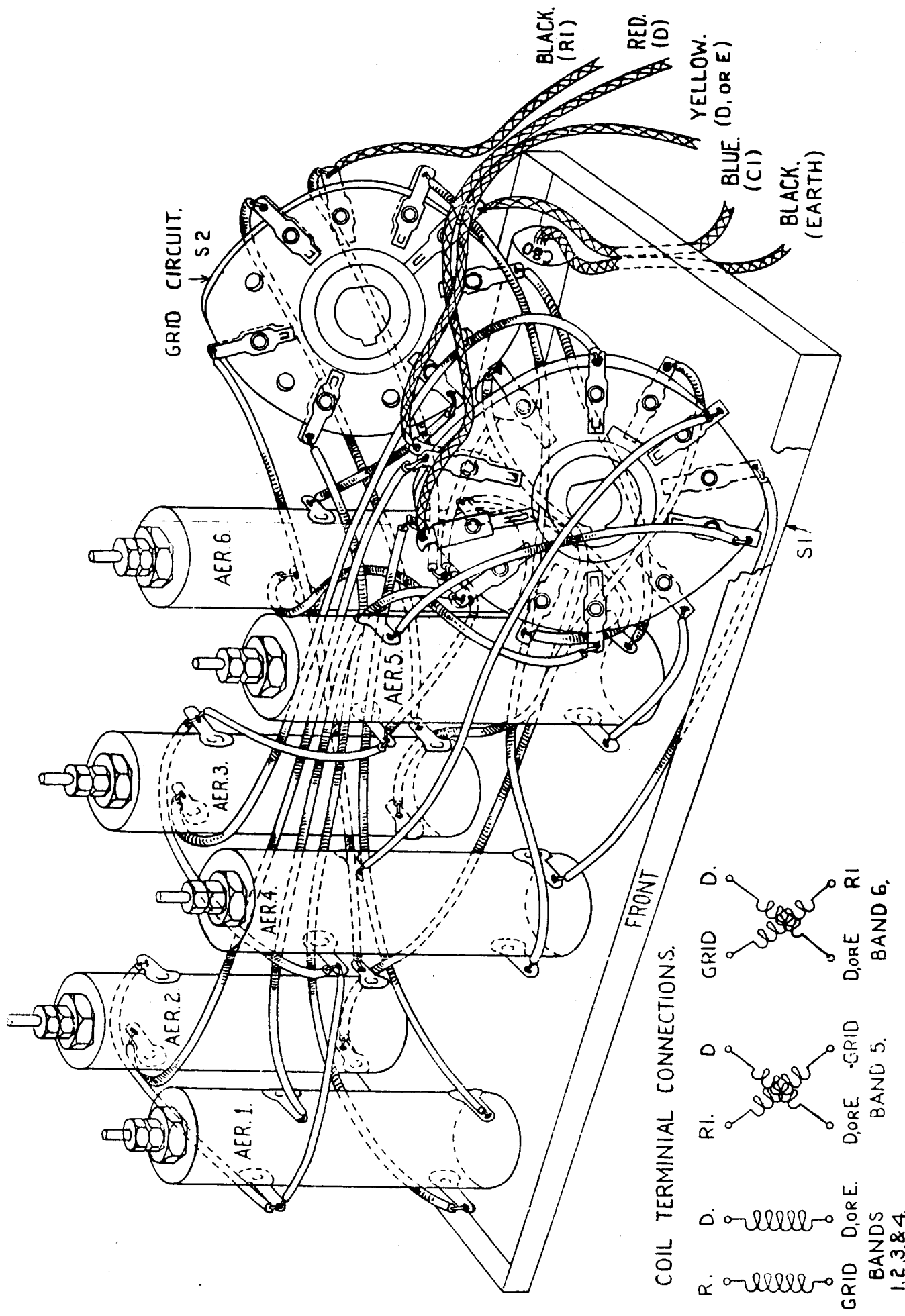
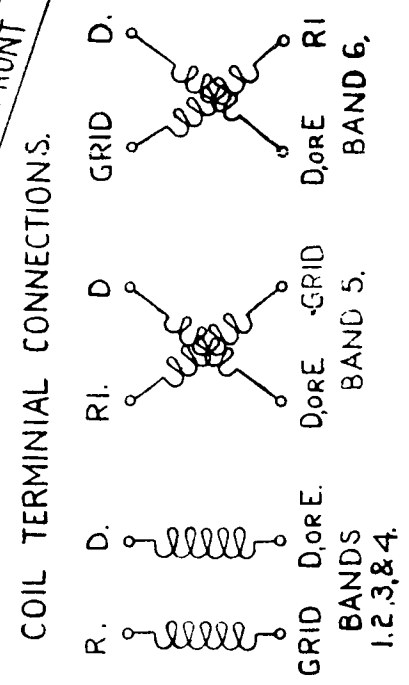

Fig. 22. COIL ASSEMBLY. AERIAL SECTION.





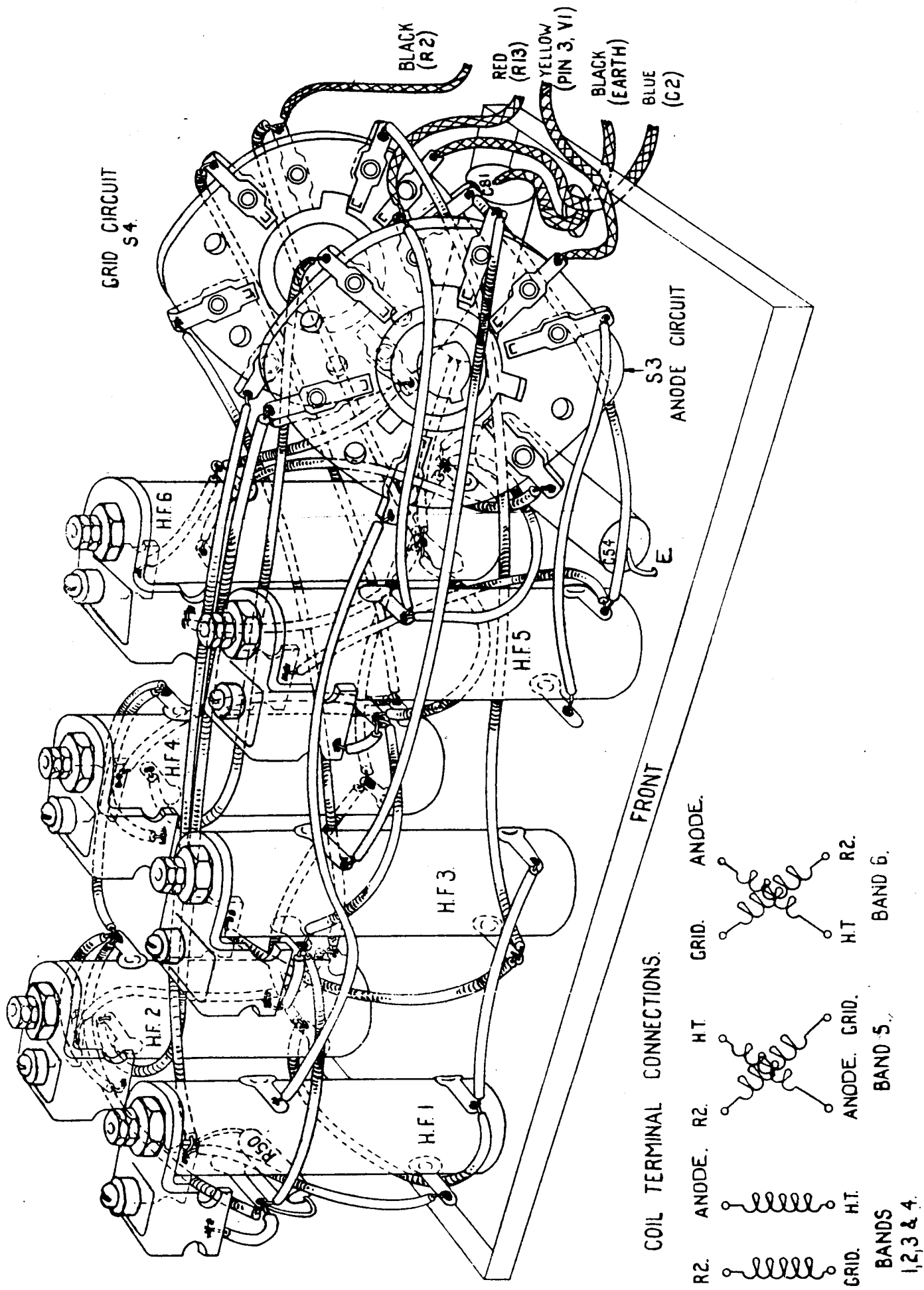

Fig. 23. COIL ASSEMBLY. H.F. SECTION.

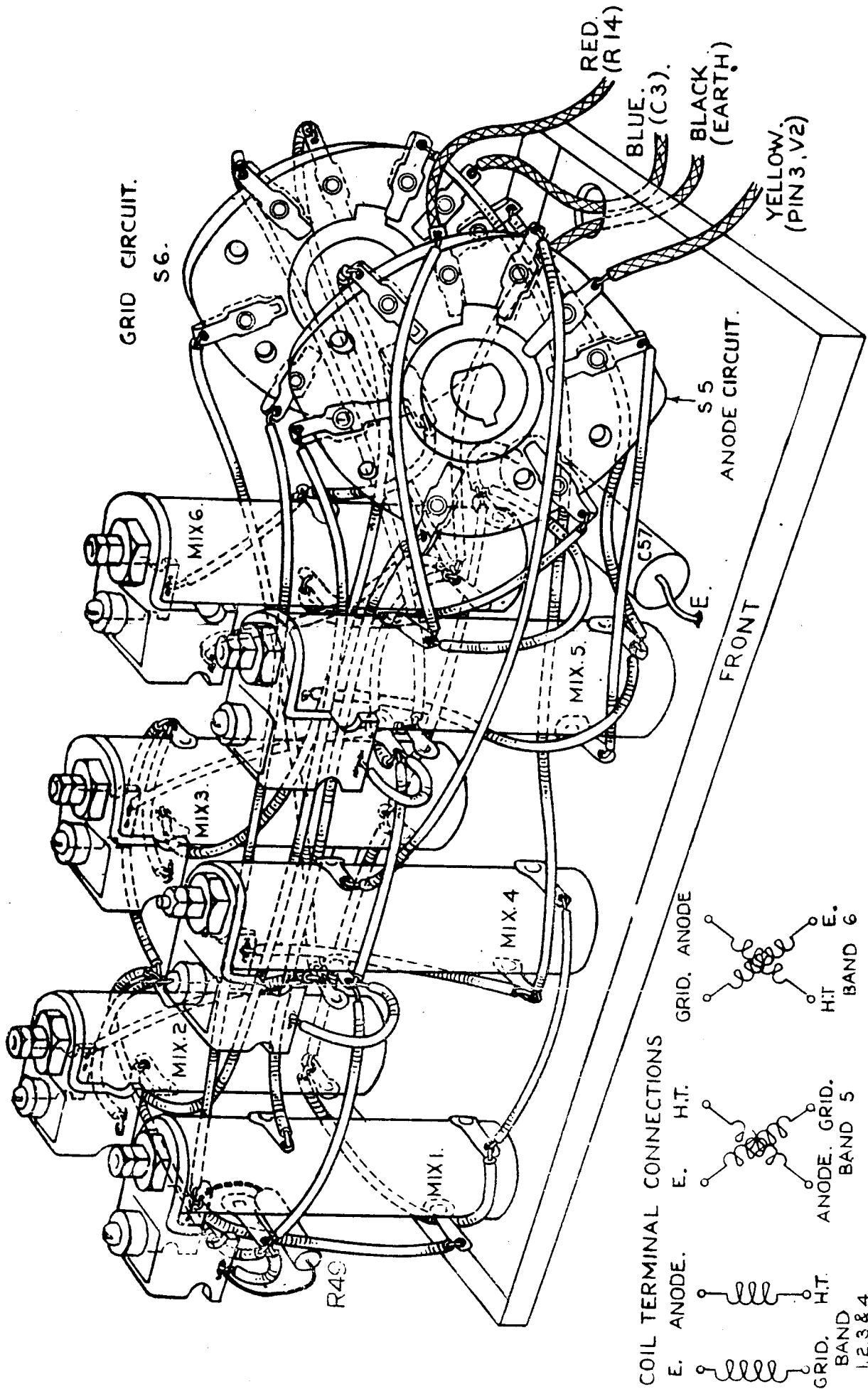

Fig. 24. COIL ASSEMBLY. MIXER SECTION.

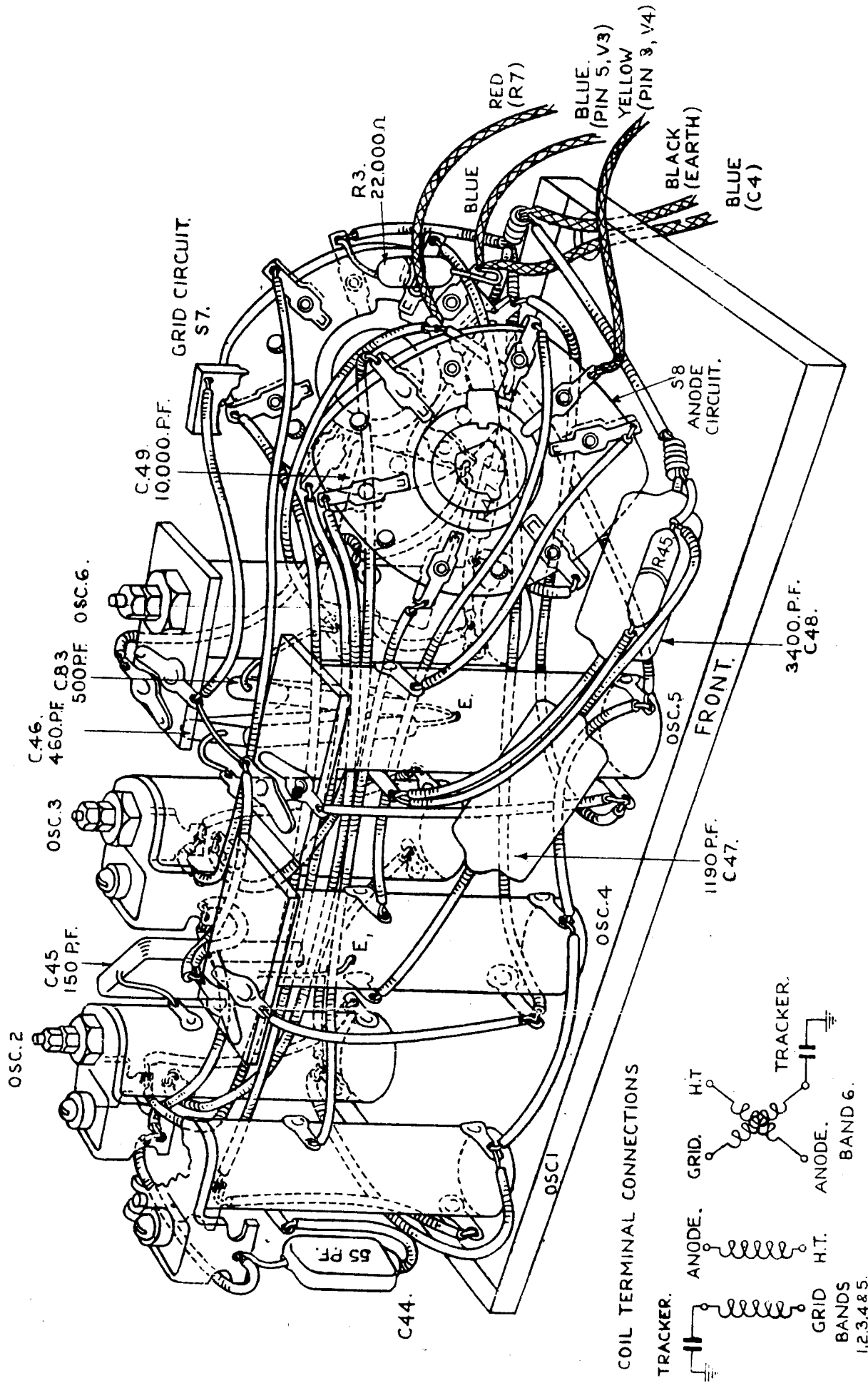
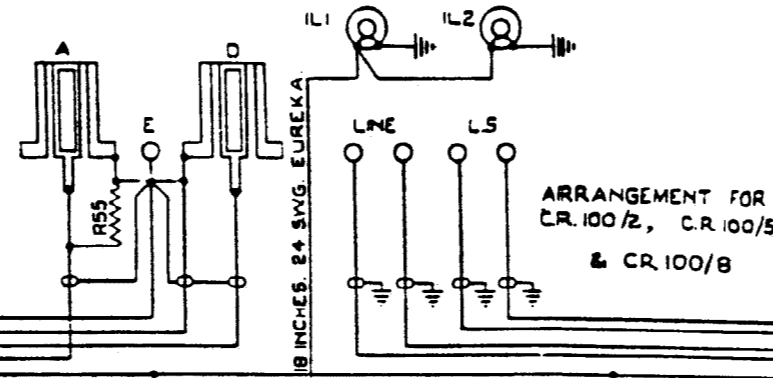
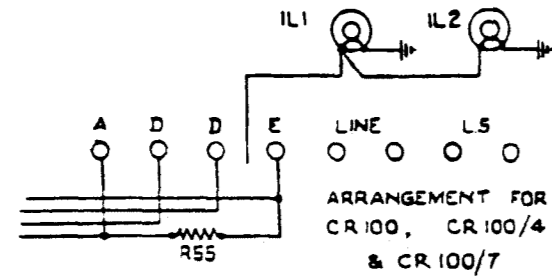
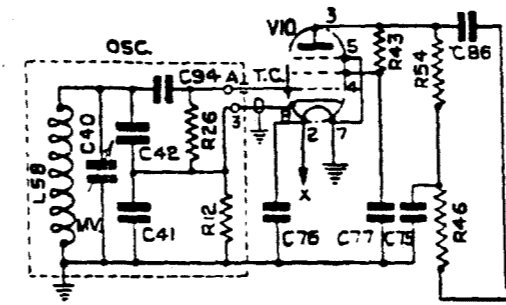

Fig. 25. COIL ASSEMBLY. OSCILLATOR SECTION.

ALL SWITCHES SHOWN FULLY  
COUNTER-CLOCKWISE.  
CONTACTS AS VIEWED FROM FRONT.  
FRONT ROTOR MARKED F.  
REAR ROTOR MARKED R.  
⊕ INDICATES SCREENED LEAD  
WITH SCREENING EARTHED.



BEAT FREQUENCY OSCILLATOR



H.T. RECTIFIER

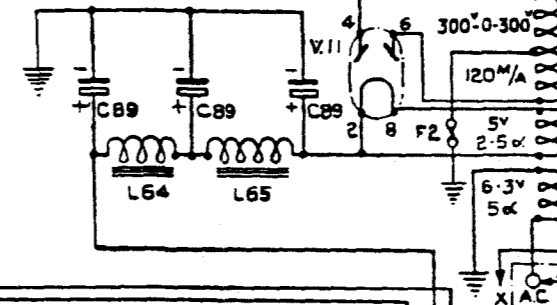

SOCKET FOR AC MAINS

