

# Getting The Most From Your AR88

SERVICING, ADJUSTMENT AND MAINTENANCE

D. M. GILL (4S7MG)

*Whether or not you own an AR88, this article is a useful and important contribution to the literature on receivers. If you do run an AR88, it will suggest many ways in which the receiver can be improved—and may also explain why some are not such good performers as they are expected to be. Even if you are not the possessor of an AR88 (and at least you will have heard of it) this article will be worth reading because it deals with many of the finer points on amateur-band communications receivers generally.—Editor.*

THE very large number of AR88 receivers to be found in amateur stations all over the world is a testimony to its excellence, but it is not unlikely that some of them are not performing as well as their owners would wish. It is difficult to run a "Servicing Course" in one short article—even on one particular type of receiver. What follows is based on practical knowledge gained over a period during which a great many AR88's have been put into good order. The work entailed is *not* for beginners, so if you are inexperienced in receiver repairs read on by all means, but do not start messing about with your AR88 unless you know what you are doing or have a knowledgeable friend on hand who can help you out of any difficulty.

The first thing to look over when checking any receiver is the power unit. Usually this is all right. The transformer in the AR88 runs hot so do not get alarmed unless it starts to *smell*. The HT should be about 250 volts when the receiver is switched on. If lower try a new rectifier valve. On standby, the HT rises to about 550 volts so do not replace the smoothing condensers with electrolytics unless they are good ones rated 550v. working. The total HT current is 80 milliamps with no signal input and RF gain at maximum. One curious thing about the two smoothing chokes is that one is of 800 ohms resistance and the other 400 ohms. Fig. 1 shows the circuit. L50, of course, should be the 400-ohm choke. Sometimes they are the wrong way round,

resulting in slightly less available HT voltage and the 800-ohm choke getting rather hot.

The audio section is shown in Fig. 2. Though the output transformer has never been known to go faulty, plenty of the coupling condensers, C118, to the grid of the output valve have been found to have low resistance; this results in less negative bias and excessive anode current. It does not seem to hurt anything but it is better to replace this condenser if the old one is showing signs of leaking. Without a valve-voltmeter the only way of checking C118 is to measure the anode current of the 6V6 with and without the condenser connected.

The most likely place for trouble is the anode and screen resistors (R38, R40, R41 in Fig. 2) of the 6SJ7 audio amplifier. These seem to go high very easily and it is recommended that they be replaced as a matter of course. The working voltages on screen and anode of the 6SJ7 are low when functioning correctly; the reading should be about 30 and 60 volts respectively. Replace R38, R40 and R41 with 1 watt resistors and be sure. It is likewise suggested that all the "mica-mold" condensers, in the flat bakelite case, are also replaced; these are all poor quality and usually have low values of insulation. The writer has always used the Hunts midget tubulars with the brown case and found them successful.

## The LF Side

The audio signal voltage required at the grid of the 6SJ7 to give a good output level is very small; somewhere about 1 volt r.m.s. The bias to the 6V6GT output valve is about 15 volts negative which is equal to the peak grid input voltage, giving an effective value of about 10 volts r.m.s. Assuming a gain of the 6SJ7 stage of about 100 times without feedback and reduced to about 20 times with the feedback *via* R54 and R39, this makes the input to the grid of the 6SJ7 about 0.5 volt for full output. This calculated figure is within reasonable agreement of the measured value. In passing it should be mentioned that C118 (0.006  $\mu$ F) was replaced by a .01  $\mu$ F at first and it was found that reproduction was too bassy for communication reception. With this value the low frequency response was well maintained below 100 cycles/second. Both .005  $\mu$ F and .0001  $\mu$ F were tried and for clarity of speech the latter value was preferred; this is really a personal choice. If you like bass put in .01 and if you are a DX man try .0001



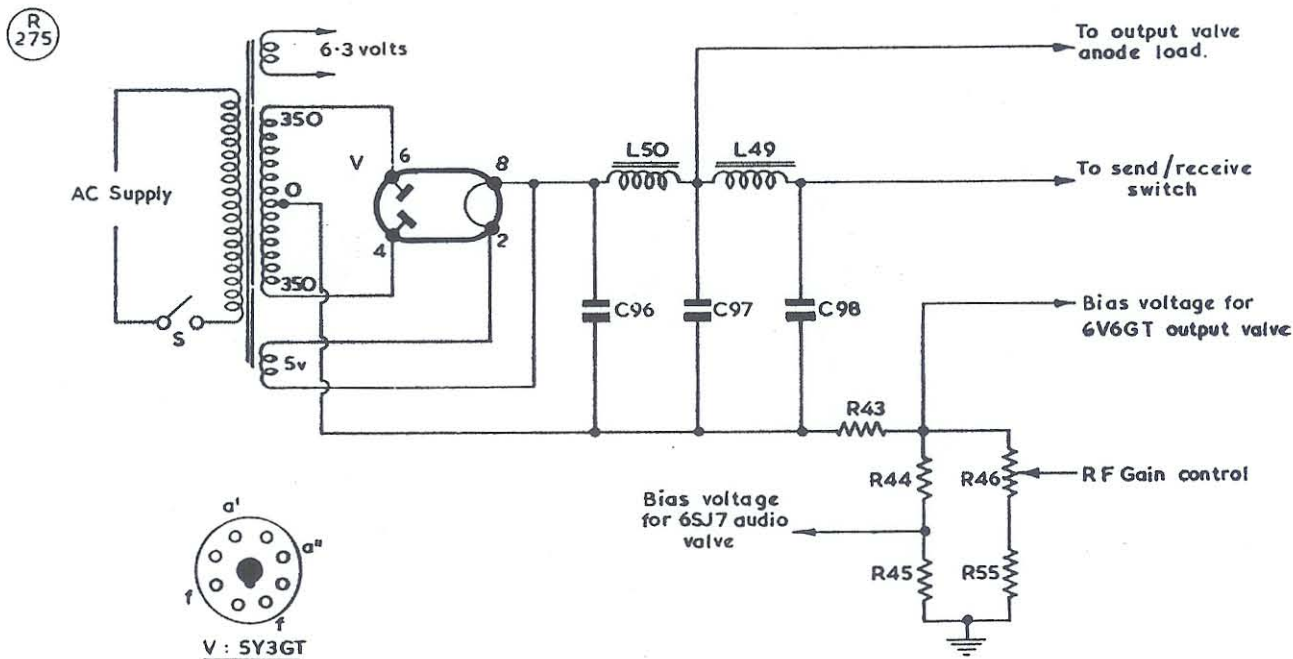

Fig. 1. Power supply section of the AR88, not showing the circuit arrangement for feeding the receiver from batteries (these can be connected through an 8-pin socket on the rear apron of the chassis). The great majority of AR88's will, of course, be operated from a normal AC supply, and it is in connection with the mains power unit that some observations are made in the text.

$\mu$ F. Condenser C118 is within the feedback loop and does not change the bass response as much as expected, because, of course, of the negative feedback. Condenser C111 is the best one to change if you wish to experiment with different responses at the low frequency end of the audio range.

The second detector and noise limiter come next, and are shown in Fig. 3. These are nothing very special, although the two diodes in the noise limiter look a little odd at first sight. The circuit as given is shorn of all the fancy switching. Both V8 and V9 are 6H6 valves; the signal diode is internally connected to pins 5 and 8 of V8; the diode load comprises R48 and R49 totalling 99,000 ohms. This feeds the noise limiter diodes in V9. The actual limiter is a simple series acting type but it is very effective in operation, as we all know. This is due to the second diode (pins 5 and 8) which improves weak signal limiting in an indirect way. If a high value of resistance is connected between the plate and cathode of a thermionic diode the anode will build up a negative voltage with respect to the cathode due to electron emission from the cathode. This happens with a series noise limiter diode but for weak signal action the plate should be slightly positive with respect to cathode. It is this self-generated electronic potential that spoils weak-signal limiting. The second diode (pins 5 and 8 of V9) produces

**Table of Values**

Fig. 1. The AR88 Power Supply Unit

C96, C97 = 4 $\mu$ F	R55 = 6,800 ohms
R43 = 100 ohms	L49 = 800-ohm 60 mA choke
R44 = 150 ohms	L50 = 400-ohm 80 mA choke
R45 = 15 ohms	V = 5Y3GT rectifier
R46 = 66,000 ohms	

(Note: Circuit element numbering is in accordance with AR88 manual.)

a potential which tends to cancel the potential of the limiter diode and thus improves its action. The heater current of the noise limiter diodes is limited by two 10-ohm resistors connected in parallel, R69 and R70. The reason is to limit the emission of these two diodes and again improve the limiting.

**Noise Limiter Action**

It may be as well here to give a brief picture of how a series limiter works as it will help in adjusting and finding faults in any limiter. The RF potential at pin 5 of V8 (in Fig. 3) is half the carrier envelope as shown in Fig. 4(A). If noise due to ignition is present the noise appears as large "spiked" peaks on the carrier, as shown in Fig. 5(B). At the top end of the diode load (R48 and R49) the RF has been removed and only the outline of the carrier appears as an alternating audio voltage superimposed upon a steady negative potential. This is shown in Fig. 6. We now have the audio voltage with noise



peaks which we want to remove. It should be noted that theoretically the noise peak cannot become large in the positive direction as the signal diode shorts them to earth. In practice this is not quite true as the signal diode has not zero resistance and small peaks are sometimes present on the positive side, but for our discussion we shall not complicate the explanation by considering these. Fig. 7 shows a simplified diagram of a series noise limiter using the same component designations as in Fig. 3 round V8, but with the potential bucking diode omitted. The cathode of the NL diode takes the potential of the top end of the diode load resistor, R48. In the absence of a carrier it should be slightly negative and it will hold at whatever potential it assumes because of the long time constant of R35 and C109 + C110. The anode of the NL diode is less negative than its cathode because it is tapped down the signal diode load. This is equivalent to saying the NL diode anode is slightly positive and therefore conducting. In this state the NL diode is conducting and most of the audio signal voltage is developed across R50. Should the receiver pick up impulsive noise from a car ignition system the noise "spikes" will appear on the negative side of the audio voltage and if the NL diode is correctly adjusted it will stop conducting on these peaks. This is probably better illustrated by Fig. 8, where the signal developed across the diode load (R48 and R49) is drawn along the line NM with noise peaks out to

the left. When these peaks pass beyond the left of the vertical line O the diode stops conducting and consequently does not pass them on. The audio signal is passed by the NL diode and developed across R50, represented along line PQ. It will be seen that the noise peaks are considerably reduced.

The degree of clipping depends upon the setting of the NL anode along R48, which alters the operating point P along the line OR. The more it is moved to the left (nearer to the top end of the signal diode load) the sooner the clipping takes place. This causes clipping or limiting to start earlier and if adjusted too much it clips the modulation peaks and produces that peculiar distortion with which we are all familiar.

This has been rather a long diversion on the clipper but a complete understanding will help to clear up troubles in this part of the circuit. The writer's experience is that clippers are usually difficult to test without a controlled source of impulse noise and a couple of oscilloscopes to examine the waveform. If the

**Table of Values**

Fig. 2. Audio Section of the AR88

C99, C112 = 0.25 $\mu$ F	R41 = 100,000 ohms
C111 = .003 $\mu$ F	R42 = 330,000 ohms
C117, C118 = .006 $\mu$ F	R54 = 2,700 ohms
R36 = 2.2 megohm	R56 = 5 ohms
R37 = 1 megohm	Tone = 1 megohm
R38 = 1.5 megohm	V1 = 6SJ7
R39 = 100 ohms	V2 = 6VGT
R40 = 270,000 ohms	

(Note: Circuit element numbering is in accordance with AR88 manual.)

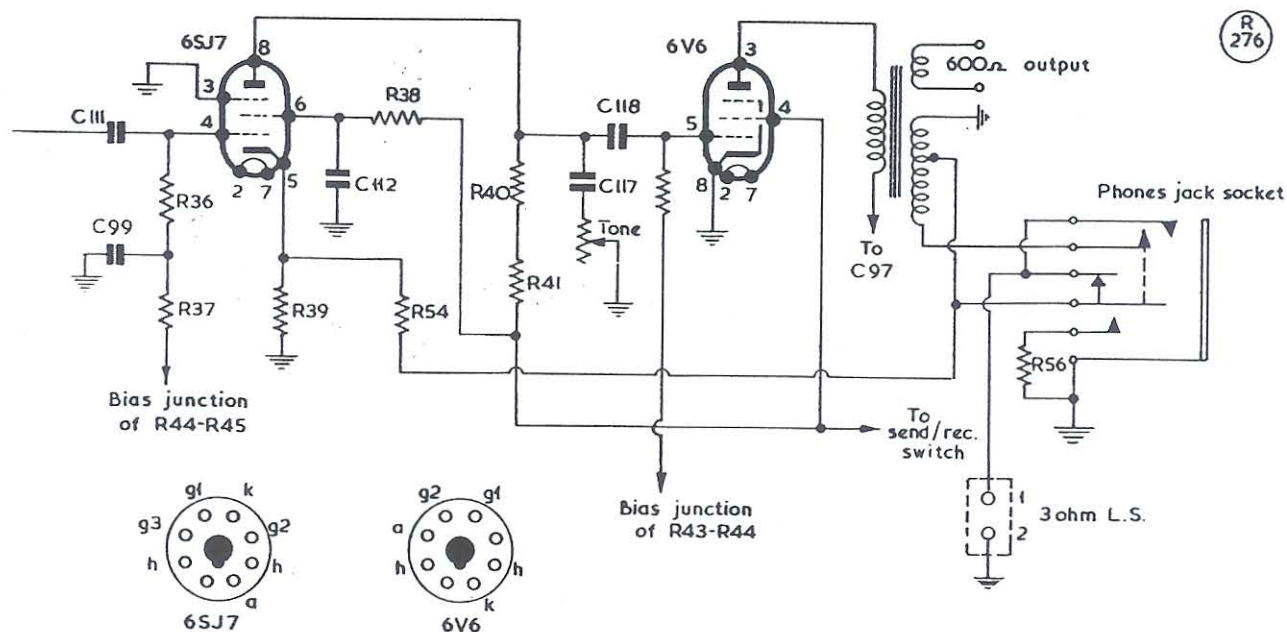
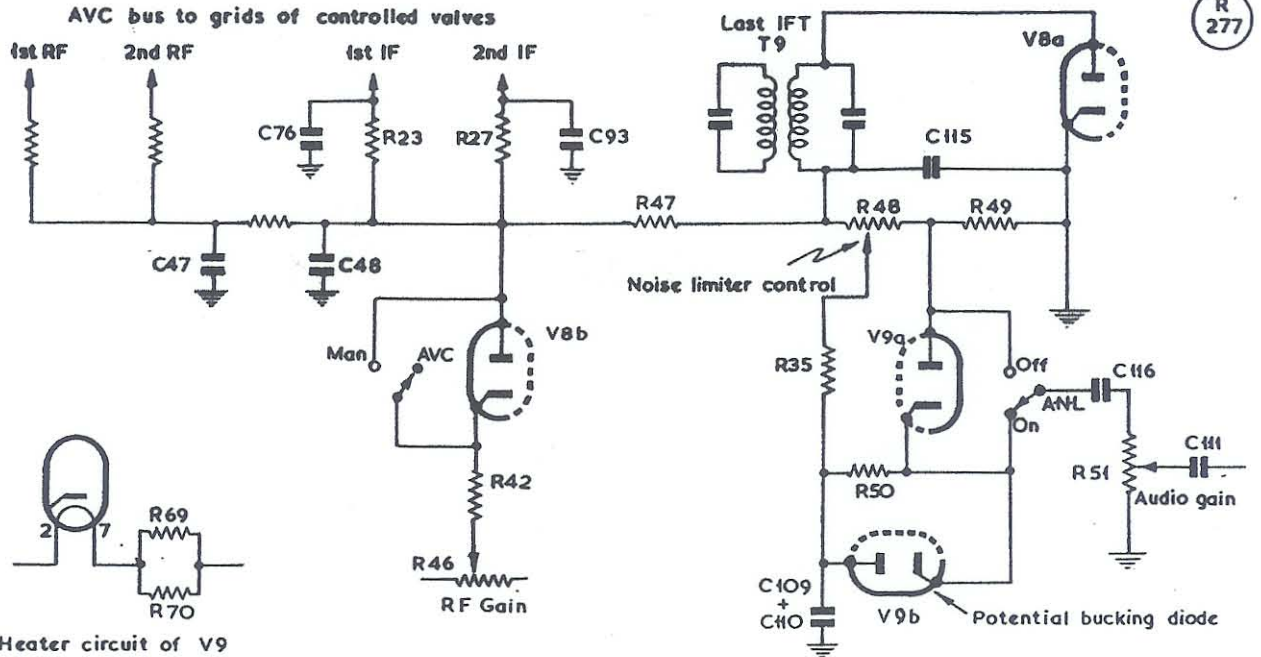

Fig. 2. This is the audio section of the AR88, for which all relevant values are given in the table. The bias resistor in the grid of the 6V6 (unmarked in this diagram) is R42, 330K. The circuit element numbering is as in the AR88 manual.





R 277

Fig. 3. The signal diode and noise-limiter circuitry of the AR88, as discussed in the text. As all who use one know, the noise-limiter in this receiver is particularly effective.

ANL is not so good and you feel it should be better the easiest and quickest way is to remove all the resistors and replace them with new ones. This may seem extravagant—it is, but some amazing improvements have resulted in a few cases though, of course, in many instances it makes no difference at all. Do not forget to substitute new 6H6's to check if this shows any improvement.

The AVC line is quite ordinary. Here the gain is controlled by setting the actual grids at a certain negative potential dependent upon the setting of the RF gain control R46. This negative voltage is passed through the diode (pins 3 and 4) in V8—see Fig. 3. When the

**Table of Values**

Fig. 3. Signal Diode and Noise Limiter, AR88

C47 = .006 $\mu$ F	R42 = 390,000 ohms
C48 = .005 $\mu$ F	R46 = 66,000-ohm potentiometer
C76, C93 = .01 $\mu$ F	R47 = 2.2 megohms
C109, C110 = 0.1 $\mu$ F together	R48 = 66,000 ohms
C111 = as Fig. 2	R49 = 33,000 ohms
C115 = 180 $\mu$ F	R51 = 2 megohms
C116 = .003 $\mu$ F	V8, V9 = 6H6
R23, R27, R50 = 560,000 ohms	
R35 = 680,000 ohms	

(Note: Circuit element numbering is in accordance with AR88 manual.)

FIGURE 4

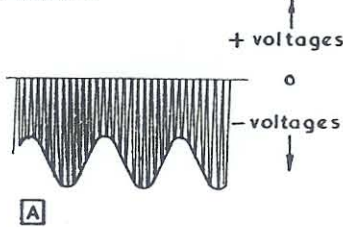
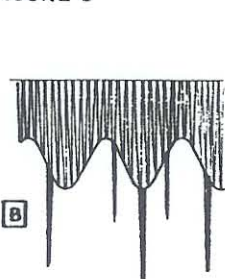

FIGURE 5



R 278

Action of the noise limiter in the AR88. In (A) Fig. 4 is shown the RF voltage at the anode of the signal diode, as seen on an oscilloscope. The positive half of the carrier is suppressed, leaving the negative half-cycles of modulated carrier. In (B) Fig. 5 the noise peaks are shown superimposed on the modulated carrier. These pulses would be of varying amplitude and irregularly spaced.

AVC develops negative bias it is not shorted to earth through V8 as the diode will not conduct in this direction. When the control is switched to manual this diode is shorted out and any AVC potential is also partially shorted out—only partially because of R42, value 390,000 ohms. If you wish to have true manual control with no AVC action whatsoever, cut out R42 altogether; this resistor is on the "MAN-AVC" switch wafer.

**AVC Points**

What can go wrong with the AVC? Two things. Resistors can go high and condensers low. R47, which is nominally 2.2 megohms, has on occasions been known to go as high as 5 megohms, and the condensers C48, C76 and C93 as low as 15 to 10 megohms each. Individually, this does not mean very much but when all are taken together it means that the controlled valves are only getting about half the AVC voltage that they should. Such a fault results



in RF distortion on strong signals and shows up as audio distortion in the output. The simplest way to check the AVC is to measure the value of R47 and if it is over 2.2 megohms replace it. Next, break the AVC line from R47; switch to "AVC" and measure the resistance of the line to earth with either an electronic ohmmeter or a low-voltage megger. The resultant line insulation should not be less

FIGURE 6

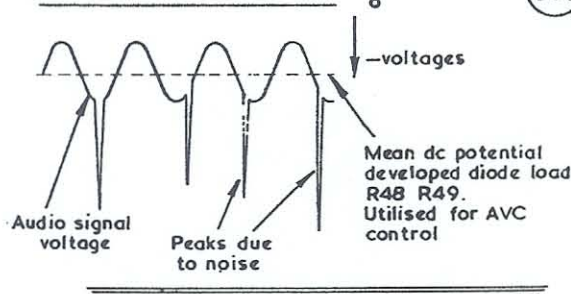

FIGURE 7

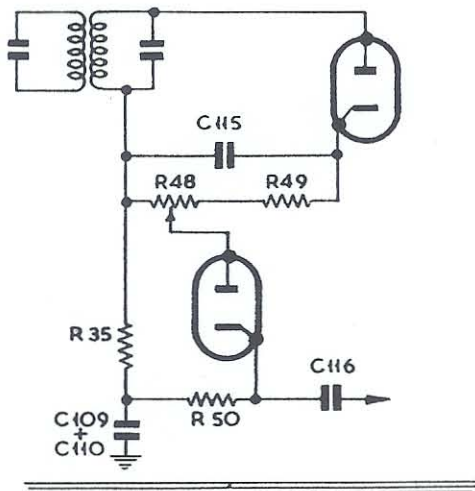
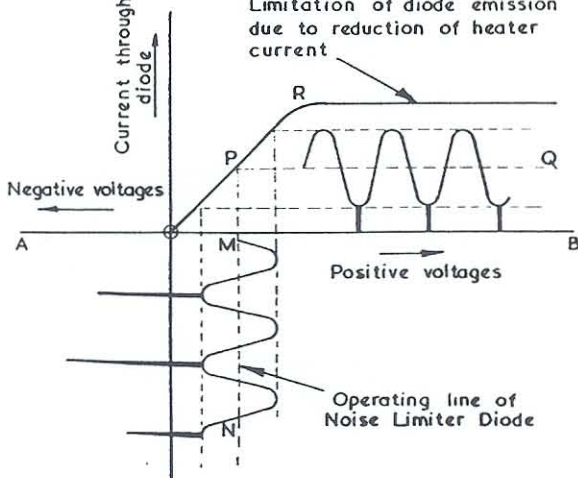

FIGURE 8



Action of the noise limiter in the AR88 — see text and Figs. 4A and 5B.

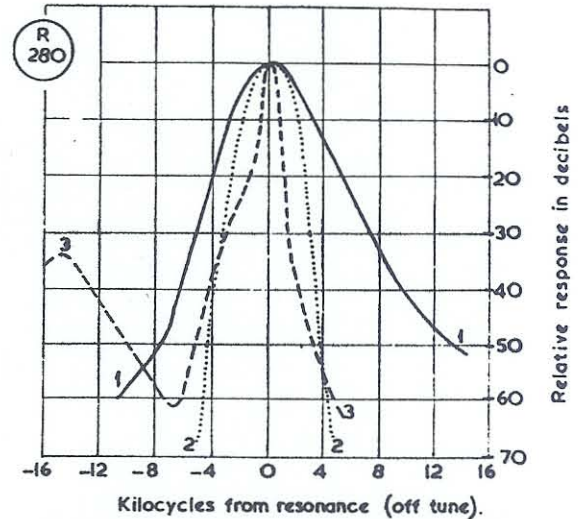

Fig. 9. Selectivity of the AR88. Curve (1) is the response obtained on selectivity position 2; Curve (2) is the makers' published figure for position 2; Curve (3) is the response obtained on position 3 (first crystal position) on an AR88 aligned without a wobulator.

than 50 megohms. If it is less, disconnect each condenser *i.e.* C47, C48, C76, C93, in turn and locate the faulty one. Normally, these metal clad condensers are very good and do not leak, but sometimes the odd receiver is found where they have a low insulation in the order of 10 megohms. A couple of these in parallel soon lowers the insulation of the AVC line and reduces the control voltage.

### The IF Section

We now move on to the IF section. This is the heart of any receiver as it gives the major part of the gain or amplification and all the selectivity. If this is not up to scratch the receiver performance will be poor. Without a decent signal generator and some previous experience it is difficult actually to check the performance of this section. For the sake of completeness various measurements will be described.

First, it will probably come as a shock to many to be told that the selectivity of these "surplus" AR88 receivers is not, in fact, very good; the curves come nowhere near the maker's published curves—see Fig. 9. At least that is the writer's experience with a large number of "surplus" models obtained in various ways. At the time of writing, the AR88 receiver is still being manufactured in its original form, with slight modifications, and these new models are vastly superior to any of the old ones handled. The loss in selectivity is due to a gradual deterioration of the IF coils and condensers. The condensers can be replaced by modern "hi-Q" ceramics of the



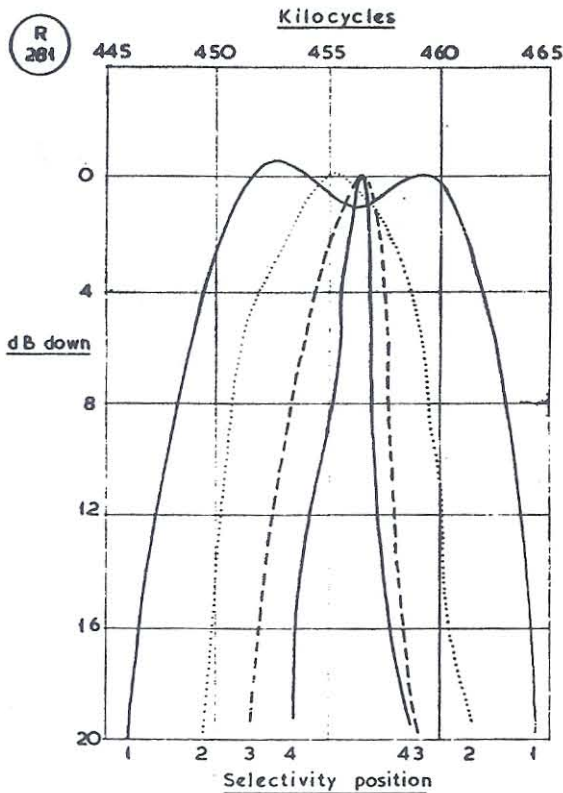

Fig. 9A. Response curves for a carefully adjusted and aligned AR88 — compare with Fig. 9. Maximum response in each selectivity position is called 0 dB so that various curves can be compared.

same value. It will make a little difference but it is hardly worth all the trouble of taking out each IF transformer. (New transformers cost U.S. \$7.50 each.) The “Q” of some IF coils has been measured and found to be between 80 and 110; this is hardly high enough for a receiver of this class. The design figure is not known but is thought to be not less than 140.

If no test gear is available the receiver can be approximately aligned by tuning in a steady signal, switching to AVC and adjusting each trimmer for maximum deflection of the S-meter; selectivity should be on position 3 so that one tunes to the crystal frequency. If not, the IF will be tuned to a frequency different from the crystal and then there will be a big drop in signal strength when switching from posn. 2 to posn. 3. This is the rough method. For alignment the writer prefers a wobulator and an oscilloscope to draw a picture of the selectivity curve. If you wish to double hump the response on posn. 1 of the selectivity switch and get a symmetrical response on posn. 3 (first crystal position) a wobulator is the only quick reliable method. Low wobulator sweep speeds are required

when examining the crystal response curves. Positions 4 and 5 are normally too sharp to obtain a decent picture. The associated trimming condenser can be adjusted for the best response possible and left at that. There is usually a change in gain between the various positions of the selectivity switch. Changing from posn. 2 to posn. 1 results in a 6 dB reduction in gain but it is of no consequence as this position can only be used on strong signals. If the IF circuits are correctly aligned with the crystal frequency there will be a slight increase in gain when switching from posn. 2 to posn. 3. There is a progressive drop in gain when going to posns. 4 and 5.

Figure 9A shows the response of a typical AR88 receiver in selectivity positions 1, 2, 3 and 4. They vary a little from receiver to receiver. On position 2 the curve is about 5 kc wide at 3 dB down. Unfortunately these curves do not tell the whole story as the responses start to bell-out when some considerable kilocycles off-tune, resulting in poor skirt selectivity. To illustrate the enormous improvement that can be made by modern methods, Fig. 10 shows the result with an ordinary AR88 receiver on position 2 compared with the same receiver fitted with a mechanical IF filter of 3 kc bandwidth. Curve 2. As a warning to those who feel inclined to rush out and buy a mechanical filter — *don't!* They are not at all easy to fit as the receiver must have no selectivity of its own around the pass band, otherwise it will distort the “square” response of the mechanical filter. Two other snags are that 3 kc bandwidth is hardly wide enough for intelligible speech and tuning to the side to take one sideband is not always practicable as the

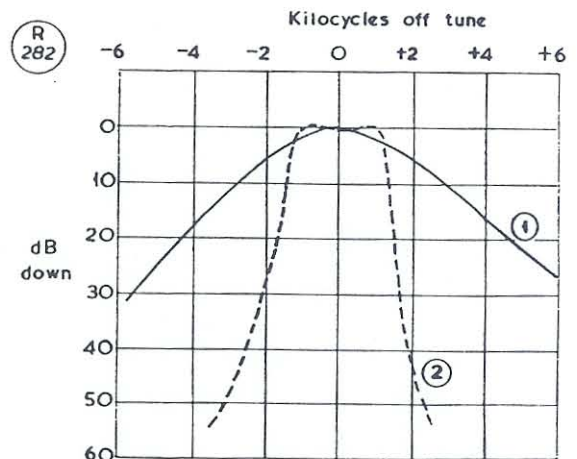

Fig. 10. Curve (1) is the response obtained on an “ordinary” AR88 at selectivity position 2. Curve (2) is the response, on the same receiver, in selectivity position 1 with a 3 kc mechanical IF filter fitted.



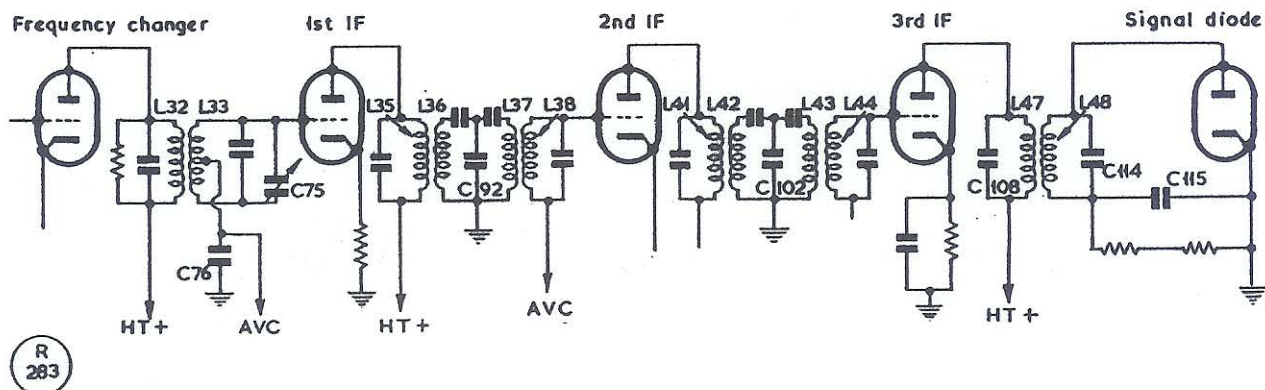

Fig. 11. Essential circuitry of the AR88 when switched to selectivity position 2—see text and Figs. 9, 9A and 10.

receiver will frequently howl due to acoustic feedback to the oscillator tuning condenser of the gang. You will also find that the oscillator is not as rock steady as you thought!

The IF circuit looks complicated on the diagram with all the valve feeds but it is quite ordinary when stripped to the signal circuit alone. Look at Fig. 11 to see this. When switching to the crystal positions 3, 4 and 5, the circuit following the frequency changer alters slightly and is shown in Fig. 12. As mentioned earlier a wobulator and scope are essential for obtaining symmetrical response on crystal, selectivity position 3. Even with this aid a considerable amount of juggling with C75 and L34 is necessary before the required response is obtained. Sometimes the contacts on the selectivity switch do not "make" properly, which can result in either no signal in some of the positions, or super selectivity in position 3. This switch also brings additional coupling into operation on the transformers between the first and third IF valves for double-humped wide response in position 1. In some receivers the poor skirt selectivity has been traced to this wiring. It allows the IF signal to leak round the tuned circuits. Cutting out the wiring and earthing the coils (not shown in any of the simplified diagrams) direct to chassis sometimes shows an improvement but it is hardly worth spoiling the re-sale value of the receiver for a doubtful improvement, unless you have a standard signal generator on hand to measure the improvement or otherwise.

The next important thing about the IF amplifier is its gain and, of course, this is difficult to measure without our old friend the standard signal generator. If the signal grid of the frequency changer is disconnected from the circuit and returned to earth through the terminating unit of the signal generator the receiver should give a good output when the

signal generator feeds about 500 microvolts to the grid. If it requires an input of 1,000 microvolts you can start looking for a fault. The gain of the IF amplifier from the grid of the frequency changer to signal diode is about 10,000 times. As this figure (10,000) can easily be achieved in a 4-valve receiver you may ask why is it so low? Actually more is not required as it would be unnecessary. If you go much above this figure you require elaborate screening and filtering of the supply leads to prevent regeneration (oscillation). The reason it is not more with all these valves is because the dynamic impedance of the IF transformers is only about 45,000 ohms and there is also a considerable "loss" in the IF transformers due to the many coupled circuits. Some manufacturers design receivers with excessive gain and then reduce it by means of a resistor in a cathode. It gives them an easy means of adjusting all receivers for the same performance.

The stage gains are approximately as follows, from grid to grid:—

Frequency changer to 1st IF	× 0.8 (loss)
1st IF to 2nd IF	× 10
2nd IF to 3rd IF	× 10
3rd IF to Signal Diode	× 125

If the "feel" of the set is that it seems to lack pep the resistor (if there) in the cathode of the 2nd IF valve can be removed. A condenser can be wired across the cathode resistor of the 1st IF valve if one does not already exist. Finally, measure the value of the cathode resistor in the 3rd IF stage. These have been known to go high. Check the voltage across R55 (Fig. 1). It should not be more than 3 volts. This is the standing bias to the controlled valves; if it is greater than 3 volts ascertain why. Reducing the value of R55 to reduce the standing bias will not give any increase in gain worth talking about. If none



of these measures show an improvement you probably have a faulty IF transformer.

**Oscillator Stage**

The oscillator injects about 4 volts into the heterodyne grid of the frequency changer. The actual figure varies with the waveband in use and the position of the tuning condenser. This cannot be measured unless you have an RF valve-voltmeter with a high-impedance probe. Normally, the oscillator does not give much trouble provided it is fed with an adequate supply of HT and LT. Sometimes the receivers will suddenly start to drift badly. Across each coil is a small condenser with a negative temperature coefficient which holds the frequency of the oscillator relatively steady during the warm-up period. The writer has never known one of these condensers go faulty, but on sets that start to drift the condenser may have broken away from the coil due to vibration or rough handling.

**The RF Side**

Now we come to the RF stages, a subject on which a great deal has been written, particularly with regard to low noise. It is the writer's opinion that low-noise valves are of very little use below 30 mc—and knows he will immediately be challenged on this statement! But if the receiver is working correctly the thermal noise of the first tuned circuit will completely over-ride valve noise. You cannot ask for more than that. In a general-purpose receiver one considers that the cross-modulation characteristic and the effect the AVC may have on the signal-to-noise ratio are of equal importance to low noise and it is difficult to design all three into an RF valve.

Referring to cross-modulation: This is not easily noticed in a receiver unless it is particularly bad, or if you live close to a transmitting station, but very often the "repeat" signals one hears on the short-wave bands are cross modulation products and not really there at all. Usually this does not worry the average amateur. If you are one of the unfortunates living near a broadcast or other type of transmitter an improvement in the cross-modulation properties of the AR88 can be obtained by replacing the two existing RF valves by a couple of EF89's. The valve holders have to be changed, which means most of the coils have to be removed before the work can be carried out. It is quite a job and should not be undertaken lightly.

Talking of noise: The signal arrives at the

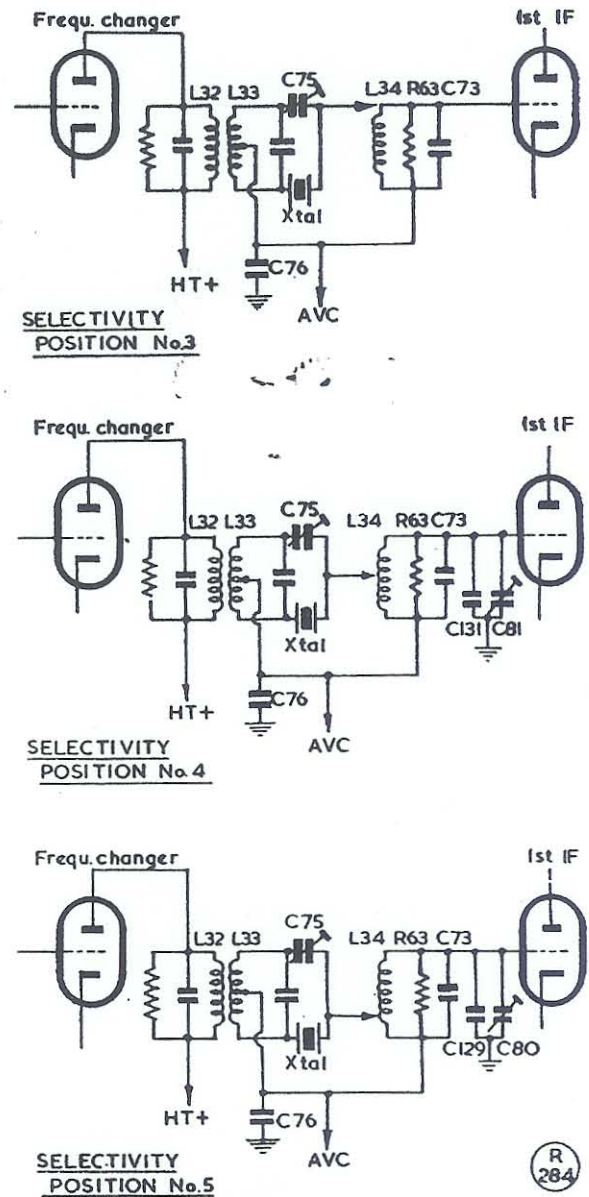

Fig. 12. Circuitry when switching to selectivity positions 3, 4 and 5 on the AR88. Note that the tapping on L34 moves down the coil on the positions of higher selectivity and additional condensers are switched in to tune the circuit.

aerial terminals together with outside noise and at the receiver output you have the signal and noise plus the noise added by the receiver. The amount the incoming signal-to-noise ratio is degraded in passing through the receiver is known as the noise factor. This factor is not constant but varies with the AVC bias. In a badly designed receiver, or one with the wrong kind of RF stage, the signal-to-noise ratio will decrease on signals up to a certain strength and then it will improve on stronger signals. This, of course, is wrong as the signal-to-noise ratio should always improve with increasing signals. Fig. 13 shows the result of measurements on an old British-made com-

(R 284)



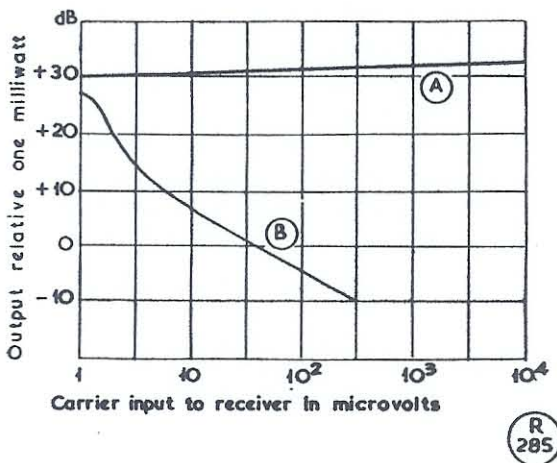

Fig. 13. The AVC performance of a reference British-made receiver — see text for discussion. These readings were taken at 11 mc, and Curve A represents audio output due to a carrier modulated to 40%; Curve B shows the noise output of the receiver for an unmodulated carrier. The difference between the two curves gives the signal-to-noise ratio expressed in dB. The result shown can be regarded as exceptionally good for a standard design.

munications receiver. Notice the wonderful AVC which holds the output constant over such a large range of input signals while the noise generated within the receiver drops as the unmodulated carrier input increases. Such a good performance is not always found in modern receivers. The AR88 when in good condition is quite capable of giving a performance equal to this *i.e.* a 10 dB signal-to-noise ratio for an input of about 2 microvolts, 40% modulated. This figure will usually deteriorate as the received frequency is increased.

The RF stages each have a gain of 10 times at 5 mc and the aerial circuit magnification is about two, giving a total of approximately 200. Nothing much ever seems to go wrong with the RF section of the AR88 except the by-pass condensers, so provided the plates and screens have 250 and 100 volts respectively and the tuned circuits are all properly aligned there is not much one can do to improve this part of the receiver. People have tried adding an extra RF stage ahead of the receiver, in the form of "R9'er." Some are successful but many are not. The reason for this is that it is no use adding a low noise booster ahead of the receiver unless it has high gain and with an additional single valve high gain is not normally obtained. Why? Because the input circuit of the receiver is designed for a 200-ohm feeder and not the high impedance required by a valve anode for high amplification.

This just about concludes the story. There is finally the S-meter which is fitted on some receivers and not others. Many owners have

#### 40-Metre (7 mc) Band

Input, dB above 1 $\mu$ V.	Developed AVC Bias	S-Meter
No Signal	4v.	6%
0dB 1 $\mu$ V	5.5v.	28%
5dB	6.0v.	34%
10dB	6.6v.	40%
15dB	7.2v.	44%
20dB 10 $\mu$ V	8.0v.	52%
25dB	8.5v.	55%
30dB	9.2v.	60%
35dB	10.0v.	64%
40dB 100 $\mu$ V	11.0v.	70%
50dB	12.5v.	77%
60dB 1mV	14.3v.	82%
70dB	16.0v.	86%
80dB 10mV	17.6v.	88%
90dB	19.0v.	88%
100dB 100mV	20.0v.	88%

#### 20-Metre (14 mc) Band

Input, dB above 1 $\mu$ V.	Developed AVC Bias	S-Meter
No Signal	2.5v.	0%
0dB 1 $\mu$ V	5.5v.	30%
5dB	5.7v.	35%
10dB	6.2v.	39%
15dB	6.5v.	44%
20dB 10 $\mu$ V	7.0v.	48%
25dB	7.7v.	54%
30dB	8.3v.	58%
35dB	9.0v.	62%
40dB 100 $\mu$ V	9.5v.	66%
50dB	11.4v.	76%
60dB 1mV	13.0v.	82%
70dB	14.5v.	86%
80dB 10mV	14.2v.	88%
90dB	17.6v.	89%
100dB 100mV	20.0v.	89%

fitted them themselves and will obligingly tell you your signal in so many S-points and believe what they say is true. To be anything like the truth they must be calibrated for each waveband used. It all depends on what one means by an "S" unit. Some standards allow the signal to increase 6 dB per S-point while others have only 4 dB between the points. A table is attached showing meter deflection, expressed as a percentage of full scale (100%) for different signal inputs at 7 and 14 mc, the measurements being done on a standard but fully "tee'd up" AR88. It is regretted they are not available for 21 and 28 mc, but the writer was not interested in these frequencies at the time as neither band was open when the measurements were made.

The 14 mc results are plotted in Fig. 14 and it is surprising how linear the readings are for inputs between 1 and 1,000  $\mu$ V. The snag



is the range of inputs from zero to  $1 \mu\text{V}$  which is essentially all noise but accounts for the first 30% deflection. Many amateur signals hardly move the pointer, indicating that they are well below  $1 \mu\text{V}$ . These are usually difficult to read. When using this scale almost every amateur appears a little hurt at producing such a weak signal and they often assume that the man on the receiver giving the poor report is "a complete clot and absolutely clueless"! Perhaps they are right—but tuning the receiver to broadcast stations in the 15 mc band will produce many 60% deflections and only a few over 80% which leads one to believe the receiver is all right. Possibly something could be done to improve the scale shape at the lower end. By the way, do not assume the same scale holds on either 21 or 28 mc; more than likely it does not, due to a change in overall sensitivity.

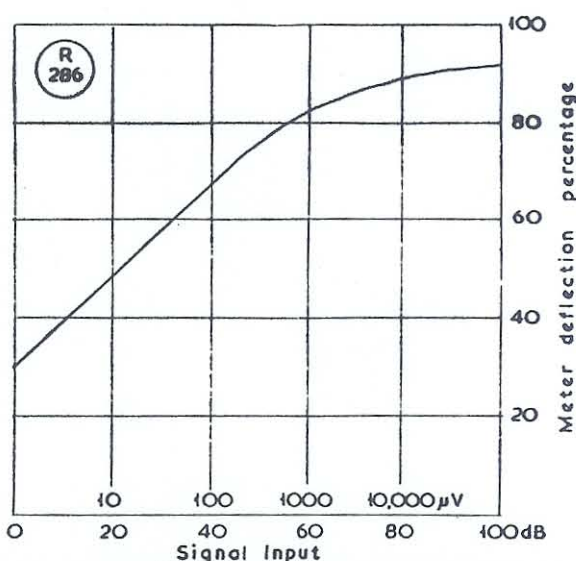

Fig. 14. Plot of the S-meter deflection on the AR88 against actual signal input on the 14 mc band. It should be noted that the shape of the curve will vary from band to band.

## New Geloso VFO Unit 4/104

### NOTES ON CIRCUIT, APPLICATION AND OPERATION

R. G. Shears, B.E.M., A.Brit.I.R.E. (G8KW)  
(K. W. Electronics, Ltd.)

RECENTLY, the well-known Italian firm of Geloso introduced a new VFO Unit to their large range of equipment for the radio amateur. This unit, known as the Model 4/104 "Signal Shifter," was designed primarily to replace the Model 4/101. Model 4/102 is still in current production and should be used as described in *Short Wave Magazine* for March 1957. The main difference between these two models is that the 4/102 is designed to drive a pair of 807's (or similar) valves in parallel, whereas the Model 4/104 will drive a single 807 or 6146. Other comparisons and differences are given in these notes, with details for operating this new VFO Unit, which uses more modern valve types than its predecessors.

#### The Circuit

The Unit consists of a pentode oscillator-buffer-doubler (6CL6) and a tetrode driver (5763 or QVO3-12). The oscillator embodies a Clapp circuit operating on a fundamental frequency in the 80-metre band for output on

80, 40, 20 and 15 metres, and in the 40-metre band for output on 11 and 10 metres. The actual frequency coverage is:

- 3.5 to 4.0 mc, for the 80-metre band;
- 3.5 to 3.65 mc, for the 40-, 20- and 15-metre bands;
- 6.74 to 7.425 mc, for the 11- and 10-metre bands.

Oscillator-tuning is accomplished by means of a three-gang (straight-line capacity variation) variable condenser. One section of it is used for 80 metres, one for 40, 20 and 15 metres, and one for 11 and 10 metre operation. A fixed capacity and a trimmer condenser connected in parallel with each section provide adjustment for exact coverage of each one of the bands. The signal generated by the oscillator section of the 6CL6 is electron-coupled to the amplifier-doubler section of this same valve, which operates as an un-tuned amplifier for 80-metre operation, and as a doubler for output on the other bands.

The 6CL6 is followed by the 5763 which amplifies for 80- and 40-metre operation, doubles for 20 metres, triples for 15 metres and doubles for 11 and 10 metres.

Switching of the Clapp oscillator circuits is accomplished by means of a single rotary switch. The plate circuits of the 6CL6 are not tuned continuously but are broad-banded and semi-fixed-tuned to a convenient frequency within the various bands. This simplification is made possible by the high C/L ratio of the circuits (which are tuned only by the inter-electrode capacities of the valves) and the small frequency range which has to be covered. The